



**INTRODUCING  
THE NEW  
MINI INVERTERS  
BY EMERGI-LITE**

**RELIABILITY THROUGH TECHNOLOGY**

# WITH TODAY'S HIGHLY EFFICIENT LED TECHNOLOGY, MINI INVERTERS ARE A RELIABLE, ECONOMICAL, HIGH-PERFORMANCE CHOICE FOR EMERGENCY POWER.

**Mini Inverters offer many advantages.** Provides a broad range of capacity for system flexibility. The Mini Inverter provides 300W to 1440W of emergency power for 30 minutes to exit signs and emergency lighting equipment. Each Mini Inverter can power many remote fixtures for a streamlined system with a small footprint. Ideal for locations with limited space to house power systems, Mini Inverters can be installed unobtrusively in a small area and added as needed to provide emergency power on each floor of larger buildings.

**Allows existing fixtures to be used as emergency lighting.** To preserve the aesthetics of high-visibility areas, the Mini Inverter can run existing normally-on light fixtures in a power failure, as an alternative to separate dedicated emergency lighting.

**Powers LED fixtures and most light sources at 100%.** When power fails, the Mini Inverter supplies 100% power/lumen output with less than 1 second of transfer, and is ideal for use with LED fixtures and most light sources except HID. Fixtures can be on, off, switched or dimmed (TRIAC dimming).



**MINI  
INVERTERS:  
EFFICIENT &  
RELIABLE  
POWER  
IN AN  
EMERGENCY**



**Compatibility with Nexus® real-time monitoring system provides even higher levels of system reliability.** With the Mini Inverter, all the advantages of Nexus® real-time monitoring system are now available for inverter-powered systems. Nexus® manages the status of the entire exit sign and emergency lighting system from a central control unit. Through wireless communication and building automation, Nexus runs diagnostics, performs required monthly and annual functional tests according to building codes, generates maintenance logs, and runs compliance reports. Nexus monitors total load on the mini-inverter from a central control unit. A Nexus® system can contribute to LEED certification and support green building initiatives.

**Reliability is built into the Mini Inverter.** The cUL listed Mini Inverter uses a long-life, maintenance-free Lead-Acid battery. Fully-featured auto-diagnostics test the batteries and lamps connected to the Mini Inverter so you can rest assured that your emergency lighting system will be on when the main power fails.

## RELIABILITY THROUGH TECHNOLOGY



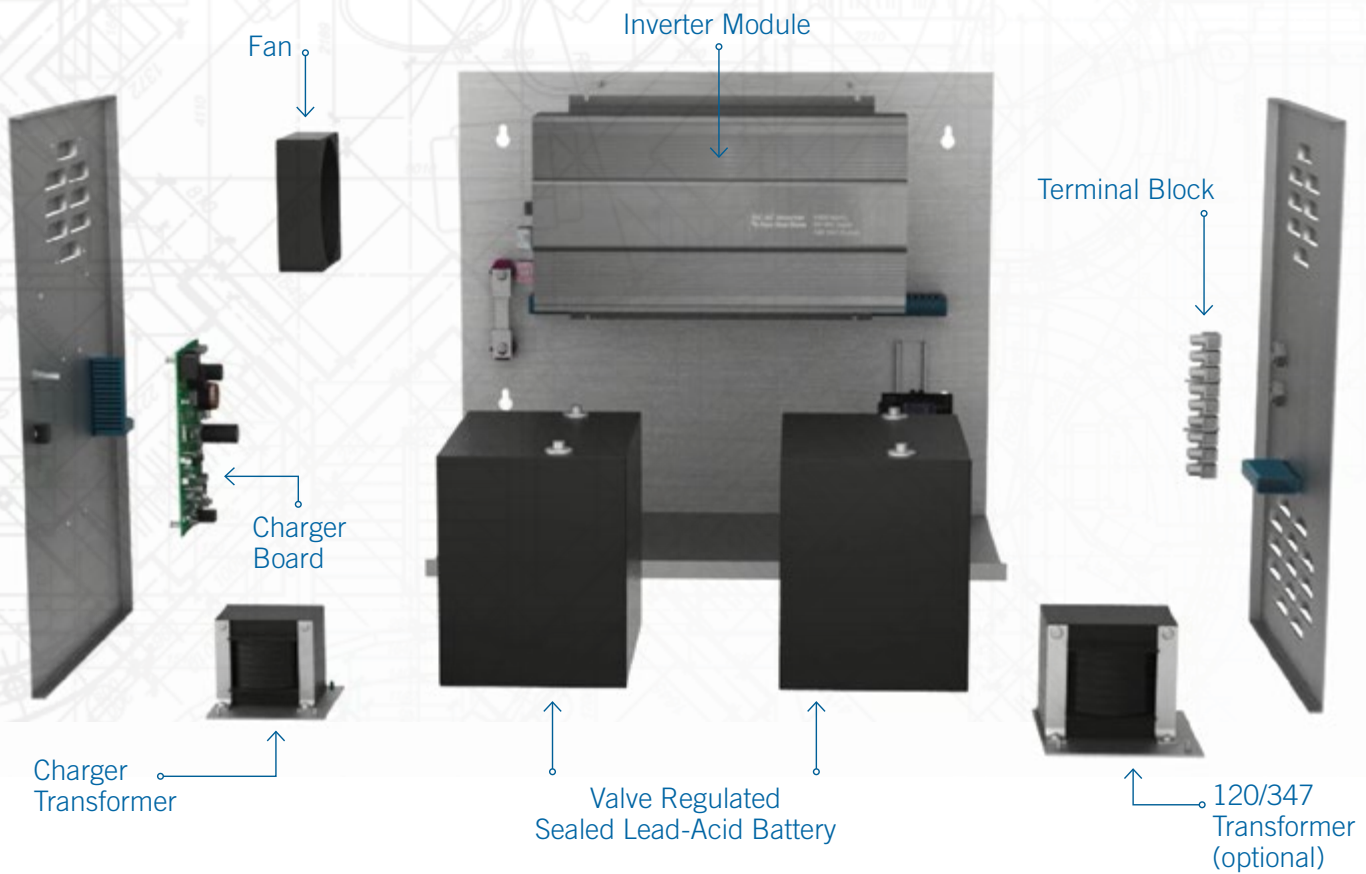

## CHOOSING THE RIGHT BACKUP POWER SYSTEM

Back-up power can be provided in many ways. However, even though certain methods are suitable for critical applications, they may not be suitable for Emergency Lighting. This is because an Emergency Lighting system has unique load characteristics. Since Emergency Lighting is a critical life safety installation, it must be designed with its specific load characteristics in mind. Mini Inverter systems are specifically designed to provide emergency power for Emergency Lighting systems in a power failure.

# MINI INVERTER FEATURES & BENEFITS

## FEATURES

### Auto-Diagnostics/Self-Testing

The diagnostic/charger is a fully self-contained, fully automatic microcontroller- based system. Any fault condition causes a status LED indicator to blink, identifying the nature of the fault. Every 30 days, the sequence generator will generate a command to energize the transfer relay for a variable test period based on code requirements (1 minute each month, 10 minutes after 6 months, and 30 minutes after 12 months).

### System Design

Inverter and charger modules utilize highly reliable solid state electronics. The modules feature input and output protection, and they measure and limit their own current.

### Capacity

Capacity is available starting at 300W up to 1440W, 120V and 347V (347V not available in 300W)

### True Sine Waveform

Using a solid-state, pulse width modulation (PWM) inverter, Mini Inverter systems produce pure sinusoidal output waveform with less than 5% Total Harmonic Distortion (THD) for linear loads.

### Nexus Monitoring System

The Mini Inverter is compatible with Nexus®, a real-time monitoring system that manages the status of the Nexus monitors total load on the mini-inverter from a central control unit. Nexus® runs diagnostics, performs required monthly and annual functional tests as per Building Codes, generates maintenance logs and runs compliance reports.

## BENEFITS

### Code Compliance

Reduces testing/service time for a minimal maintenance cost, while ensuring that local safety codes are met, and provides system reliability in a power failure condition.

### High Performance

The Mini Inverter is a rugged, easy-to-maintain system with exceptional performance for emergency lighting use. It offers exceptional overload performance without the need to over-specify the rating.

### Versatile Applications

Mini Inverter systems can be used in almost every type of building, and are ideal for architecturally sensitive applications or when maintenance costs and testing of individual unit equipment becomes significant. The smaller unit size of the Mini Inverter allows more flexibility and minimizes testing. The Mini Inverter can be installed at a distance, offering the opportunity to hide the unit from view and maintain the architectural design by powering normally-on luminaires.

### Maximum Light Output

The Mini Inverter will deliver 100% power / lumen output of the fixture up to the specified run time. It is compatible with all fluorescent ballast, LED drivers or incandescent light sources.

### Reliability Through Technology

Nexus® allows for maintenance time and cost savings, and ensures that the emergency lighting fixtures will perform when needed. Nexus® can contribute to LEED certification and support sustainability objectives.



**new** product

# MINI-INVERTER SERIES

Interruptible Unit Equipment

Type: \_\_\_\_\_  
 Project/Location: \_\_\_\_\_  
 Contractor: \_\_\_\_\_  
 Prepared By: \_\_\_\_\_  
 Date: \_\_\_\_\_  
 Model No.: \_\_\_\_\_

The **Mini-Inverter** is a cUL Listed stand-alone pure sine wave output inverter designed to provide power to designated emergency lighting fixtures. In a power loss situation, it will supply power from the onboard battery supply.

The **Mini-Inverter** works in conjunction with incandescent, LED, and fluorescent fixture types and will automatically run switched, normally-on, or normally-off designated emergency fixtures.

The **Mini-Inverter** is ideal for applications requiring an emergency source for lighting arrangements that utilize multiple lamp and fixture types and is available in surface mount and comes with a one year warranty and nine-year pro-rata battery warranty.

## FEATURES

- Lamps operated: Incandescent LED, fluorescent lamps and ballast combinations, including TRIAC dimmable ballasts
- Components: High-efficiency pure sine wave inverter
- Temperature-compensated charger 12V oversized Valve Regulated lead acid (VRLA) battery
- Construction: 18-gauge steel for 300W & 600W/ 14-gauge steel for 1000W & 1440W with a white baked-on powder coat paint finish
- Emergency lighting supplied from one convenient, reliable source
- Input/Output voltage 120/120V 60Hz or 347/347V 60 Hz
- Replaceable output fuse protection
- Valve Regulated Lead Acid (VRLA) battery provides long-life and is maintenance free
- Line voltage allows for remote mounting of emergency fixtures at distances up to 1000 feet
- Low Battery Voltage Disconnect
- Unit comes standard with electronic lockout and brownout circuits
- Meets or exceeds all National Electrical Code and Life Safety Code Emergency Lighting Requirements
- Cabinet in factory white powder-coat paint finish
- **May accept load to it's full capacity when load feature power factor of 0.9 or more**
- Non audible auto-diagnostic is standard. Nexus® system interface available with an improved minimum lost load detection of 10%
- Standard lighting control override for 0-10V dimming systems
- Meets or exceeds the requirements of CSA 141-15

## TYPICAL SPECIFICATIONS

Emergency lighting shall be provided by inverter unit equipment designed to operate designated incandescent, fluorescent and LED fixtures on emergency power at their full nominal lumen rating during the full 30 minute emergency discharge cycle. System output will be rated at \_\_\_\_\_ watts for 30 minutes and provide fused output connections to the load. The system's voltage rating shall be \_\_\_\_\_ VAC input/output nominal. The inverter unit shall allow for fused connected emergency fixture(s) to be normally on, normally off, switched or dimmed without affecting lamp operation during a power failure.

Upon utility power loss, the inverter unit shall deliver 100% of its rated output to the emergency fixtures regardless of the local switch or dimmer (TRIAC) position, and will provide power to emergency fixtures at distances of up to 1000 feet. The housing shall be manufactured using 18-gauge steel for 300W & 600W/ 14-gauge steel for 1000W & 1440W with a white baked-on powder coat paint finish.

The unit's electronics shall include a self-contained inverter section with a fully automatic, thermalcompensating variable-rate battery charger, AC lockout feature, low battery voltage disconnect, overload, short circuit and brownout protection as standard. The unit shall utilize a sealed lead acid battery with a 10-year design life. The inverter system shall be cUL Listed and labeled. The unit shall be covered under a 1-year warranty on the electronics and battery and a 9-year pro-rata warranty on the battery. It shall meet or exceed the requirements of CSA 141-15.

## SPECIFICATIONS

<b>TRANSFER TIME:</b> less than 1 second
<b>VOLTAGE REGULATION ON EMERGENCY:</b> + 3%
<b>FREQUENCY REGULATION ON EMERGENCY:</b> 60 Hz +/- 1%
<b>LOAD POWER FACTOR RANGE:</b> 0.9 leading to 0.9 lagging
<b>OPERATING TEMPERATURE:</b> 20° TO 30°C (68° TO 86°F)

## WARRANTY

All **Emergi-Lite®** inverter products receive 100% quality inspection before shipment to insure proper and satisfactory operation. When operated under normal conditions, **Emergi-Lite®** inverter products will provide years of dependable service. This unit is backed by a complete 1-year warranty against defects in material or workmanship, and a 9-year prorata battery warranty.

The inverter unit is **Emergi-Lite®** model: \_\_\_\_\_.



## ELECTRICAL CHARACTERISTICS & DIMENSIONS

POWER RATING	MAX. INPUT RATING		SINE WAVE	INSTALLATION	CABINET DIMENSIONS			NO. OF BATTERY	WEIGHT		WEIGHT W/O BATTERY	
	120VAC	347VAC			W"	H"	D"		120V	347V	120V	347V
300W	3.10	n/a	Pure	Wall	27"	12.2"	7.3"	1	55 lbs	n/a	30 lbs	n/a
600W	6.00	2.30	Pure	Wall	24"	20"	10.5"	2	105 lbs	117 lbs	55 lbs	67 lbs
1000W	11.60	3.60	Pure	Wall	24"	20"	14.5"	2	150 lbs	169 lbs	70 lbs	89 lbs
1440W	15.00	5.00	Pure	Wall	24"	20"	14.5"	2	190 lbs	214 lbs	75 lbs	99 lbs

Type: \_\_\_\_\_  
 Project/Location: \_\_\_\_\_  
 Contractor: \_\_\_\_\_  
 Prepared By: \_\_\_\_\_  
 Date: \_\_\_\_\_  
 Model No.: \_\_\_\_\_

**new** product

# MINI-INVERTER SERIES

Interruptible Unit Equipment



## WIRING DIAGRAM

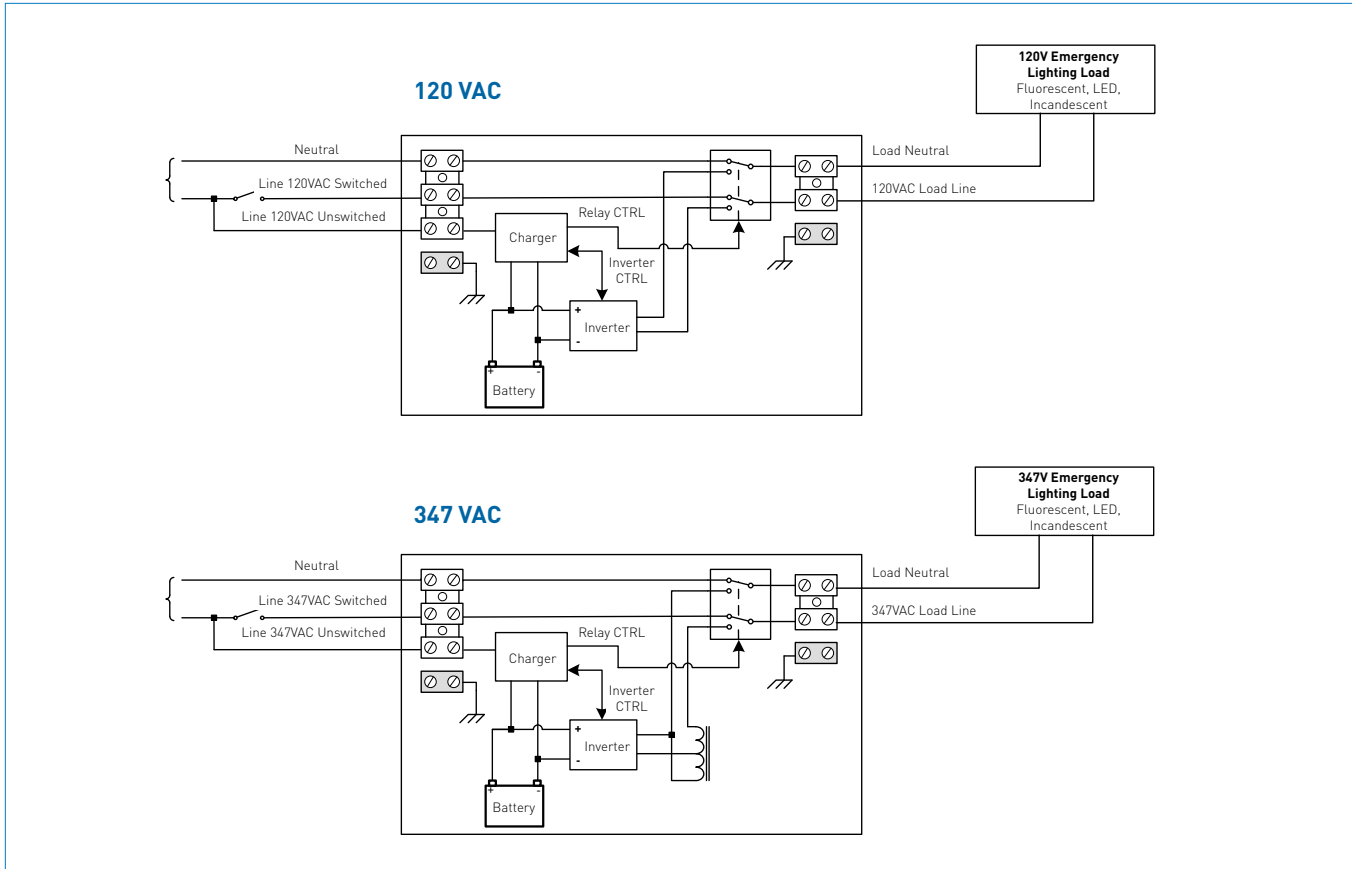

## POWER CONSUMPTION AND UNIT RATING

MODEL NUMBER	AC SPECS		EMERGENCY POWER AVAILABLE FOR LOAD				
			30MIN	1H00	1H30	2H00	4H00
EMI-300	120VAC	3.10 Amps	300W	175W	125W	100W	50W
EMI-600	120 / 347VAC	6.00 / 2.30 Amps	600W	350W	250W	200W	100W
EMI-1000		11.60 / 3.60 Amps	1000W	585W	415W	330W	165W
EMI-1440		15.00 / 5.00 Amps	1440W	842W	600W	480W	240W

## ORDERING INFORMATION

SERIES	CAPACITY	VOLTAGES IN/OUT	DIAGNOSTIC FEATURES	OPTIONS
EMI= Series	-300= 300W -600= 600W -1000= 1000W -1440= 1440W	-1= 120/120VAC, 60 Hz -3= 347/347VAC, 60 Hz*	Blank= Auto-Diagnostics, non-audible* -U= Auto-Diagnostics, audible* -NEX= Nexus® wired system interface** -NEXRF= Nexus® wireless system interface**	-D3= Time Delay (15 minutes) -LC= Line Cord (120V only) -LW= Twist Lock Plug (120V only) -SAC= Service alarm contact*
		* Available only with 600W, 1000W & 1440W	* Minimum load required: 10% of unit capacity ** Please consult your sales representative	* Not available with 1000W & 1440W capacities

EXAMPLE: EMI-1440-1

 **EMERGI-LITE®**

ON THE PROJECT, ON THE SHELF, ON THE JOB

[www.emergi-lite.ca](http://www.emergi-lite.ca)

All information and specifications contained in this flyer are subject to change due to engineer design, errors and omissions.  
Illustrations and diagrams within this flyer may vary from actual products.

© 2016. Thomas & Betts Limited. All rights reserved. Printed in Canada 10/15/2250.  
Order no. EL-MINIINVERTER-E.