

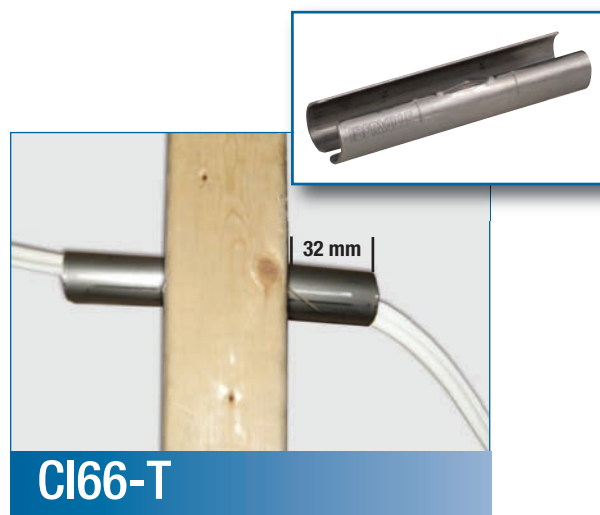

**The solution for increased cable protection.**

**The new CI66 series!**

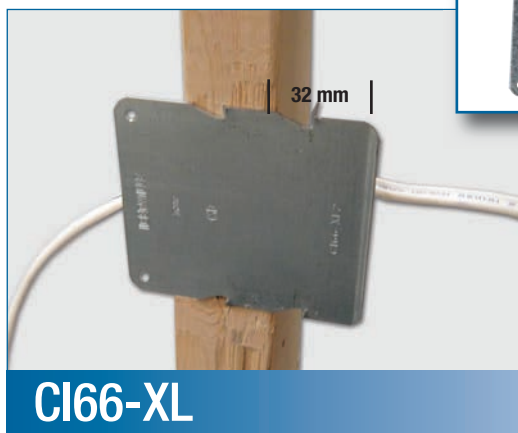

See our instruction video on [www.tnb.ca/video](http://www.tnb.ca/video)

## CI66 Series Protector Plates

Cat. No.	Description	Packaging Quantity
CI66-XL	Protector Plate	50
CI66-XL-2	Large Protector Plate	25
CI66-T	Protector Cylinder	25

## Canadian Electrical Code: Rule 12-516

Rule 12-516 (1) of the Canadian Electrical Code (CEC) states that when a non-metallic sheathed cable is run through studs, joists or similar members the cable must be at least 32mm from the edge of the members otherwise it has to be effectively protected from mechanical injury. In sub-rule (3), any cable that is installed immediately behind a baseboard shall be effectively protected from mechanical injury from driven nails.

Some provincial authorities are enforcing sub-rule (1) differently than others. While most would read this sub-rule as meaning 32mm from the front of the stud to the hole made to pass the cables (figure 1), others are insisting that 32mm distance must be from all aspects of the wood stud; depth, width, and height (figure 2).

Source : CE Handbook, Rule 12-516 Protection for cable in concealed installations.

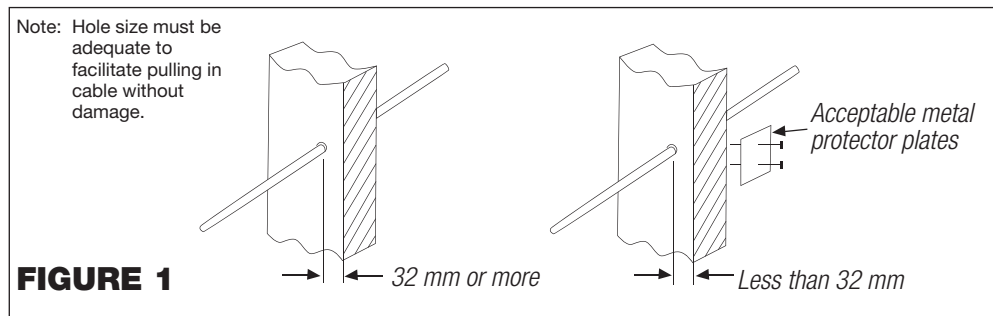

Source: CE Handbook, Figure 12-17 Cable protection

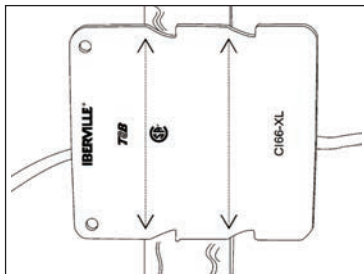

**FIGURE 2**

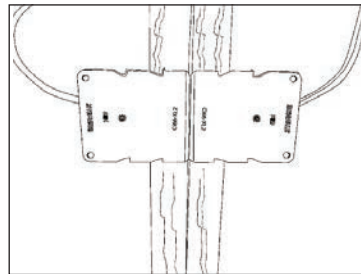

**FIGURE 3**

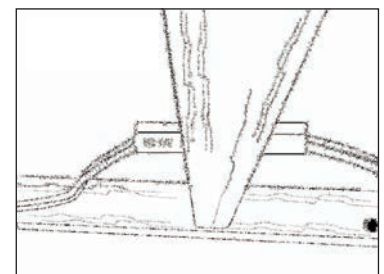

**FIGURE 4**

The Iberville team has multiple solutions to this code requirement. In the case of a single stud the CI66-XL (figure 2) or the CI66-T (figure 4) can effectively protect the cables from injury during and after drywall installations. In case where two or three studs are side by side or in corners of a room, the CI66-XL-2 (figure 3) will give the required protection.

### Atlantic Provinces

Thomas & Betts Limited  
Tel.: (902) 450-1307  
Toll Free: 1-877-862-4357  
Fax: (902) 450-1309

### Quebec

Thomas & Betts Limited  
Tel.: (450) 466-1102  
Toll Free: 1-800-465-1399  
Fax: (450) 466-1163

### Ontario

Thomas & Betts Limited  
Tel.: (905) 858-1010  
Toll Free: 1-877-291-7771  
Fax: (905) 858-1080

### Manitoba/Saskatchewan

Thomas & Betts Limited  
Tel.: (604) 598-9811  
Toll Free: 1-866-540-8220  
Fax: (604) 598-9840

### Alberta

Thomas & Betts Limited  
Tel.: (780) 424-7092  
Toll Free: 1-888-664-5666  
Fax: (780) 424-7093  
Toll Free: 1-866-424-4082

### British Columbia

Thomas & Betts Limited  
Tel.: (604) 598-9811  
Toll Free: 1-866-540-8220  
Fax: (604) 598-9840