

Channel tray

Selection guide

—
01 Solid channel

—
02 Ventilated channel

To ensure that your channel tray installation will meet your present and future needs, a sequence of decisions must be made. These decisions are relatively simple and can be condensed down to four steps.

1. Material choice

Materials

- Aluminum
- Pregalvanized steel
- Hot-dipped galvanized steel
- Stainless steel
- Coatings
- Other

T&B channel tray systems are fabricated from a corrosion-resistant metal (low-carbon steel, stainless steel or an aluminum alloy) or from a metal with a corrosion-resistant finish (zinc or epoxy). The choice of material for any particular installation depends on the installation environment (corrosion and electrical considerations) and cost. Please refer to the technical section (pages A8 to A29) for further explanation.

2. Type of tray bottom

Bottom type

- Ventilated
- Solid

Cable channel

- T&B offers cable channel in solid or ventilated straight sections.
- Ventilated channel has burr-free oblong punched holes for easy access.
- Ty-Rap cable tie slots are provided between each opening for securing of cable.
- T&B channel tray meets NEMA VE-1/CSA C22.22.

3. T&B channel tray width

Widths

- 1.5 in.
- 3 in.
- 4 in.
- 6 in.

The width of a channel tray is a function of the number, size, spacing and weight of the cables in the tray. Available nominal widths are 1.5, 3, 4 and 6 inches.

When specifying width, cable ties or other spacing devices may be used to maintain the required air space between cables.



—
01



—
02

4. Fittings selection

Fittings type

- Horizontal bends (90°, 60°, 45° and 30°)
- Horizontal tees and crosses
- Vertical bends (90°, 60°, 45° and 30°)

Fittings are used to change the size or direction of the channel tray. The most important decision to be made in fitting design concerns radius. The radius of the bend, whether horizontal or vertical, can be zero (non-radius), 12 in., 24 in. or greater on a custom basis. The selection requires a compromise with the considerations being available space, minimum bending radius of cables, ease of cable pulling and cost. The typical radius is 24 inches.

Fittings are also available for 30°, 45°, 60° and 90° angles. When a standard angle will not work, adjustable elbows can be used. It may be necessary to add supports to the tray at these points.

Refer to CSA/NEMA VE2 installation guidelines for suggested support locations.

Straight section number selection

How to create straight section part numbers

1. Select the material
2. Select nominal width of tray
3. Select the bottom type
4. The last number is the length of the channel tray

Example:

ALTC04V-3

- Aluminum
- 4 in. wide
- Ventilated bottom
- 10 ft. length

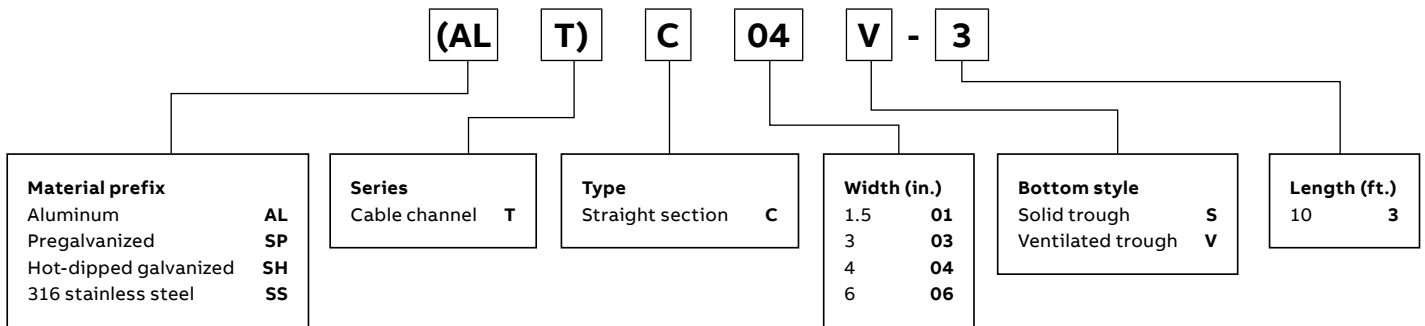

Channel tray straight lengths

Straight lengths – Solid and ventilated

01 Bottom view of ventilated channel tray larger than 1.5 in. wide

Selection guide

- Prefix: ALT (alum.), SPT (pregalv.), SHT (hot-dipped galv.), SST (stainless steel)
- Inside channel widths: 01=1.5 in., 03=3 in., 04=4 in., 06=6 in.
- Bottom styles: V– ventilated, S– solid

01

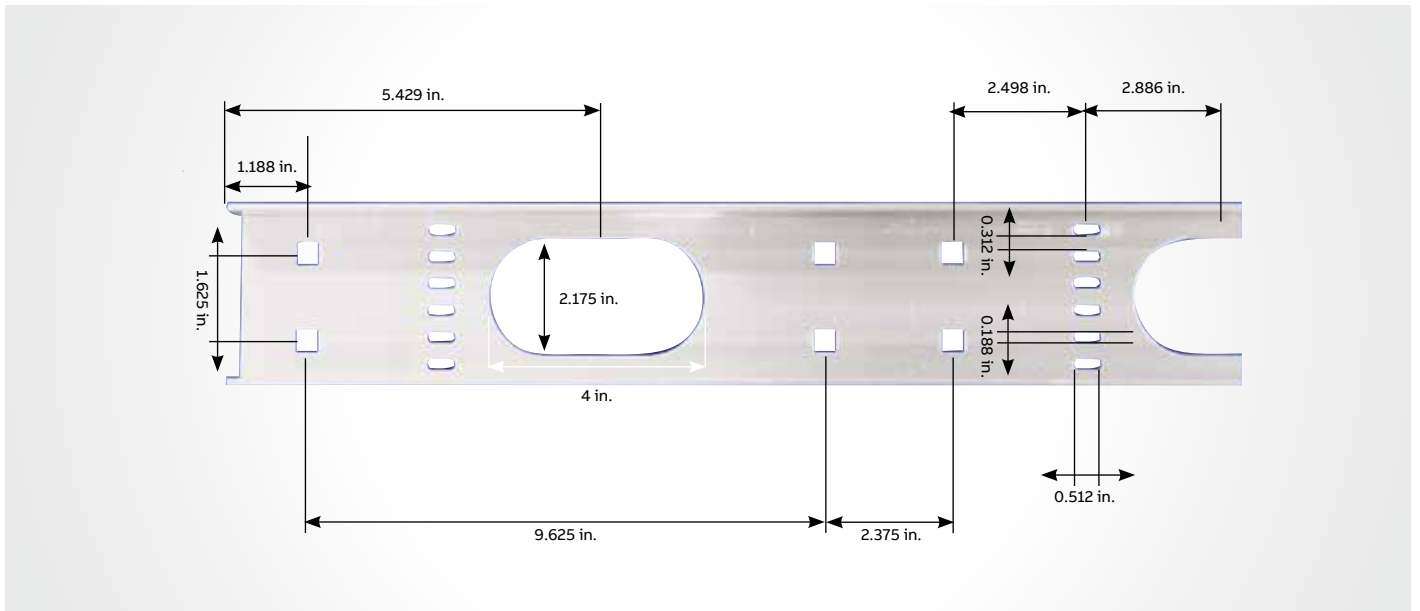

Part numbering system

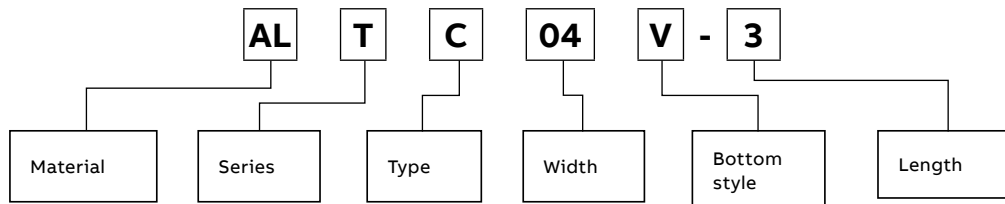

Channel tray straight lengths

Straight lengths selection guide – Solid and ventilated

—
01 Vented style offered
in 1.5 in. wide only

—
02 Vented style offered in
3 in., 4 in., 6 in. wide only

—
03 Solid offered
in all widths



—
01



—
02



—
03

Channel tray straight lengths

Aluminum straight lengths – Solid and ventilated

Aluminum

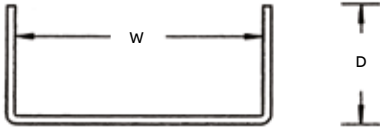

- Solid: Aluminum – extruded material
- Ventilated: Pre-punched burr-free oblong holes with Ty-Rap slots between each opening
- Accessories: One connector complete with hardware supplied with each length
- Material: Aluminum-6063-T6

Aluminum solid straight lengths

Aluminum solid	Channel width (W) (in.)	Depth (D) (in.)		Support span (feet)				
				2	4	6	8	10
ALTC	1.5	3/4	Load (lb/ft.)	47.5	11.9	5.4	3.0	1.9
			Deflection (in.)	0.170	0.680	0.745	1.325	2.070
	3	1 1/8	Load (lb/ft.)	362.5	90.6	40.3	22.7	17.0
			Deflection (in.)	0.083	0.330	0.743	1.322	2.065
	4	1 1/8	Load (lb/ft.)	580.0	145.0	64.4	36.3	24.0
			Deflection (in.)	0.065	0.260	0.585	1.041	1.626
	6	1 3/4	Load (lb/ft.)	607.5	151.9	67.5	38.0	25.0
			Deflection (in.)	0.061	0.244	0.550	0.977	1.527

Aluminum ventilated straight lengths

Aluminum ventilated	Channel width (W) (in.)	Depth (D) (in.)		Support span (feet)				
				2	4	6	8	10
ALTC	1.5	3/4	Load (lb/ft.)	47.5	11.9	5.4	3.0	1.9
			Deflection (in.)	0.170	0.680	0.745	1.325	2.070
	3	1 1/8	Load (lb/ft.)	300.0	75.0	33.3	18.8	14.0
			Deflection (in.)	0.100	0.400	0.900	1.600	2.500
	4	1 1/8	Load (lb/ft.)	525.0	131.3	58.3	32.8	19.0
			Deflection (in.)	0.074	0.295	0.664	1.181	1.846
	6	1 3/4	Load (lb/ft.)	580.0	145.0	64.4	36.3	21.0
			Deflection (in.)	0.065	0.261	0.587	1.044	1.631

Channel tray straight lengths

Steel straight lengths – Solid and ventilated

Steel

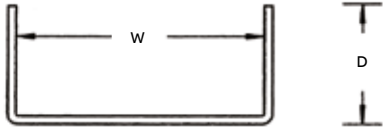

- Solid: Steel – roll-formed steel
- Ventilated: Pre-punched burr-free oblong holes with Ty-Rap slots between each opening
- Accessories: One connector complete with hardware supplied with each length
- Material: Pregalvanized, hot-dipped galvanized, 316 stainless steel

Steel solid straight lengths

Steel solid	Channel width (W) (in.)	Depth (D) (in.)		Support span (feet)				
				2	4	6	8	10
SPTC SHTC SSTC	1.5	¾	Load (lb/ft.)	97.5	24.4	10.8	6.1	3.9
			Deflection (in.)	0.045	0.181	0.408	0.725	1.133
	3	1⅝	Load (lb/ft.)	252.0	63.0	28.0	15.8	17.0
			Deflection (in.)	0.034	0.134	0.302	0.538	0.840
	4	1⅝	Load (lb/ft.)	408.0	102.0	45.3	25.5	24.0
			Deflection (in.)	0.026	0.105	0.237	0.421	0.658
	6	1¾	Load (lb/ft.)	432.0	108.0	48.0	27.0	25.0
			Deflection (in.)	0.024	0.096	0.217	0.386	0.603

Steel ventilated straight lengths

Steel ventilated	Channel width (W) (in.)	Depth (D) (in.)		Support span (feet)				
				2	4	6	8	10
SPTC SHTC SSTC	1.5	¾	Load (lb/ft.)	97.5	24.4	10.8	6.1	3.9
			Deflection (in.)	0.045	0.181	0.408	0.725	1.133
	3	1⅝	Load (lb/ft.)	207.0	51.8	23.0	12.9	14.0
			Deflection (in.)	0.041	0.163	0.366	0.652	1.018
	4	1⅝	Load (lb/ft.)	363.0	90.8	40.3	22.7	19.0
			Deflection (in.)	0.030	0.119	0.269	0.477	0.746
	6	1¾	Load (lb/ft.)	405.0	101.3	45.0	25.3	21.0
			Deflection (in.)	0.027	0.106	0.239	0.425	0.664



Channel tray

Fittings

- 01 Horizontal cross
- 02 90° Horizontal bend



Fittings number selection

How to create fitting part numbers

1. Select fitting material
2. Select nominal width of fitting
3. Select type of fitting
4. Select degree of angle if required
5. Select radius

Example:

ALTF04SHB4512

- Aluminum
- 4 in. wide
- Horizontal bend
- 45° degree
- 12 in. radius

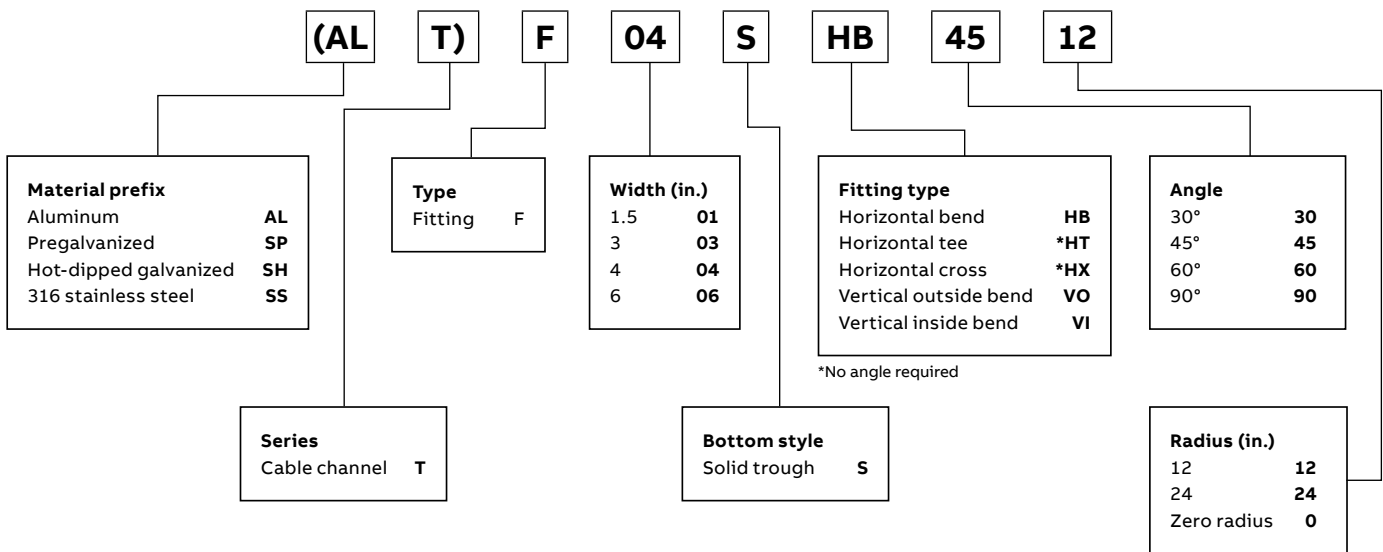

Channel tray fittings

90° Horizontal bend fittings

90° Horizontal bend



	Radius R (in.)	Width W (in.)	Cat. no.*	Dimensions (in.)	
				X	Y
	12	1.5	(Prefix)-F 01-S-HB90-12	15¾	15¾
	12	3	(Prefix)-F 03-S-HB90-12	16½	16½
	12	4	(Prefix)-F 04-S-HB90-12	17	17
	12	6	(Prefix)-F 06-S-HB90-12	18	18
	24	1.5	(Prefix)-F 01-S-HB90-24	27¾	27¾
	24	3	(Prefix)-F 03-S-HB90-24	28½	28½
	24	4	(Prefix)-F 04-S-HB90-24	29	29
	24	6	(Prefix)-F 06-S-HB90-24	30	30

*Specify prefixes ALT, SPT, SHT or SST

Selection guide

- Prefix: ALT (alum.), SPT (pregalv.), SHT (hot-dip galv.), SST (stainless steel)
- Inside channel widths: 01=1.5 in., 03=3 in., 04=4 in., 06=6 in.
- Bottom style: S= solid

Part numbering system

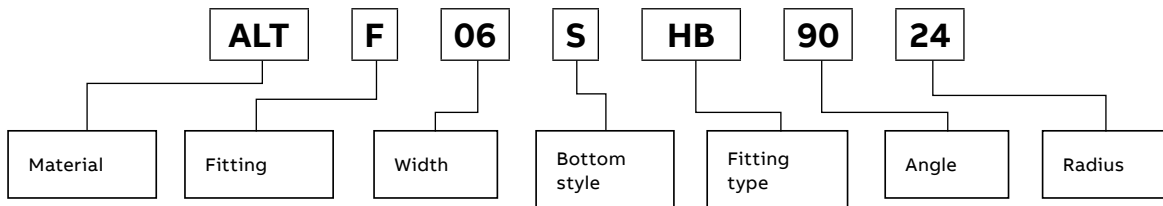

Channel tray fittings

60° Horizontal bend fittings

60° Horizontal bend



	Radius R (in.)	Width W (in.)	Cat. no.	Dimensions (in.)		
				X	Y	Z
	12	1.5	(Prefix)-F 01-S-HB60-12	15½	9	10¼
	12	3	(Prefix)-F 03-S-HB60-12	16⅞	9⅞	10⅜
	12	4	(Prefix)-F 04-S-HB60-12	16⅞	9⅞	11¼
	12	6	(Prefix)-F 06-S-HB60-12	17½	10⅞	11⅝
	24	1.5	(Prefix)-F 01-S-HB60-24	26	15	17¼
	24	3	(Prefix)-F 03-S-HB60-24	26⅞	15⅞	17¾
	24	4	(Prefix)-F 04-S-HB60-24	27	15⅞	18
	24	6	(Prefix)-F 06-S-HB60-24	27⅞	16⅞	18⅞

*Specify prefixes ALT, SPT, SHT or SST

Selection guide

- Prefix: ALT (alum.), SPT (pregalv.), SHT (hot-dip galv.), SST (stainless steel)
- Inside channel widths: 01=1.5 in., 03=3 in., 04=4 in., 06=6 in.
- Bottom style: S= solid

Part numbering system

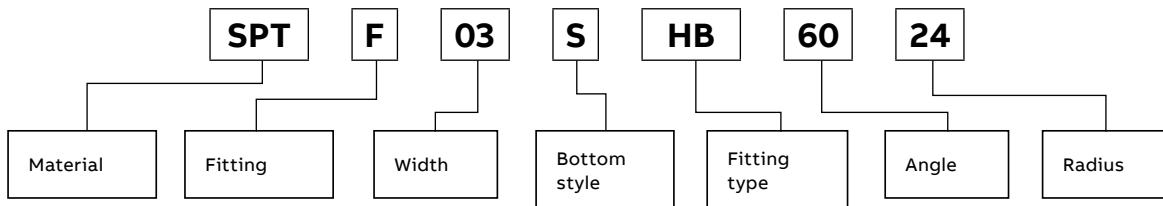

Channel tray fittings

45° Horizontal bend fittings

45° Horizontal bend

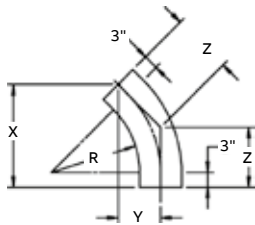

Radius R (in.)	Width W (in.)	Cat. no.	Dimensions (in.)		
			X	Y	Z
12	1.5	(Prefix)-F 01-S-HB45-12	14 ¹ / ₈	5 ⁷ / ₈	8 ³ / ₄
12	3	(Prefix)-F 03-S-HB45-12	14 ¹¹ / ₁₆	6 ¹ / ₁₆	8 ⁹ / ₁₆
12	4	(Prefix)-F 04-S-HB45-12	15	6 ³ / ₄	8 ¹³ / ₁₆
12	6	(Prefix)-F 06-S-HB45-12	15 ³ / ₄	6 ¹ / ₂	9 ³ / ₁₆
24	1.5	(Prefix)-F 01-S-HB45-24	22 ⁵ / ₈	9 ³ / ₈	13 ³ / ₄
24	3	(Prefix)-F 03-S-HB45-24	23 ³ / ₈	9 ⁹ / ₁₆	13 ³ / ₁₆
24	4	(Prefix)-F 04-S-HB45-24	23 ¹ / ₂	9 ³ / ₄	13 ³ / ₄
24	6	(Prefix)-F 06-S-HB45-24	24 ³ / ₁₆	10	14 ³ / ₁₆

*Specify prefixes ALT, SPT, SHT or SST

Selection guide

- Prefix: ALT (alum.), SPT (pregalv.), SHT (hot-dip galv.), SST (stainless steel)
- Inside channel widths: 01=1.5 in., 03=3 in., 04=4 in., 06=6 in.
- Bottom style: S= solid

Part numbering system

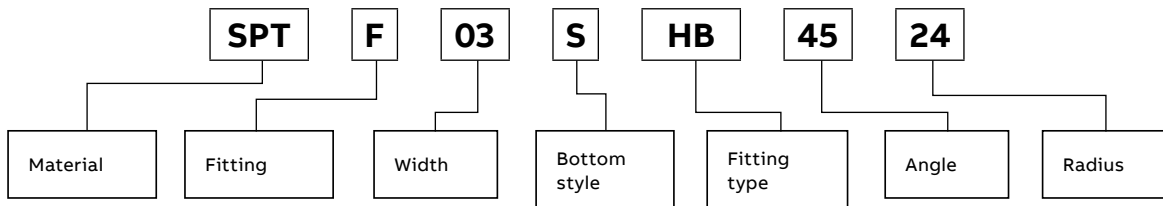

Channel tray fittings

30° Horizontal bend fittings

30° Horizontal bend



	Radius R (in.)	Width W (in.)	Cat. no.	Dimensions (in.)		
				X	Y	Z
	12	1.5	(Prefix)-F 01-S-HB30-12	12	3 ³ / ₄	6 ¹ / ₂
	12	3	(Prefix)-F 03-S-HB30-12	12 ³ / ₈	3 ³ / ₁₆	6 ⁵ / ₁₆
	12	4	(Prefix)-F 04-S-HB30-12	12 ⁵ / ₈	3- ³ / ₈	6 ³ / ₄
	12	6	(Prefix)-F 06-S-HB30-12	13 ¹ / ₈	3 ¹ / ₂	7
	24	1.5	(Prefix)-F 01-S-HB30-24	18	4 ³ / ₄	9 ⁵ / ₈
	24	3	(Prefix)-F 03-S-HB30-24	18 ³ / ₈	4 ¹⁵ / ₁₆	9 ¹³ / ₁₆
	24	4	(Prefix)-F 04-S-HB30-24	18 ⁵ / ₈	5	9 ¹⁵ / ₁₆
	24	6	(Prefix)-F 06-S-HB30-24	19 ¹ / ₈	5 ¹ / ₈	10 ¹ / ₄

*Specify prefixes ALT, SPT, SHT or SST

Selection guide

- Prefix: ALT (alum.), SPT (pregalv.), SHT (hot-dip galv.), SST (stainless steel)
- Inside channel widths: 01=1.5 in., 03=3 in., 04=4 in., 06=6 in.
- Bottom style: S= solid

Part numbering system

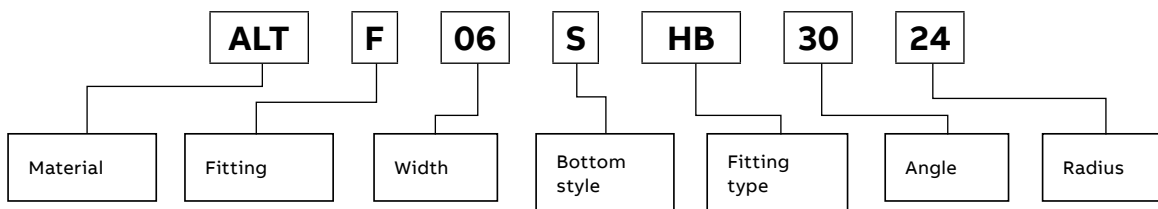

Channel tray fittings

Horizontal tee fittings

Horizontal tee



	Radius R (in.)	Width W (in.)	Cat. no.	Dimensions (in.)	
				X	Y
	12	1.5	(Prefix)-F 01-S-HT-12	15¾	31½
	12	3	(Prefix)-F 03-S-HT-12	16½	33
	12	4	(Prefix)-F 04-S-HT-12	17	34
	12	6	(Prefix)-F 06-S-HT-12	18	36
	24	1.5	(Prefix)-F 01-S-HT-24	27¾	55½
	24	3	(Prefix)-F 03-S-HT-24	28½	57
	24	4	(Prefix)-F 04-S-HT-24	29	58
	24	6	(Prefix)-F 06-S-HT-24	30	60

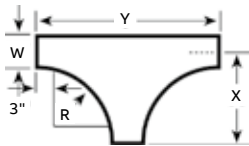

*Specify prefixes ALT, SPT, SHT or SST

Selection guide

- Prefix: ALT (alum.), SPT (pregalv.), SHT (hot-dip galv.), SST (stainless steel)
- Inside channel widths: 01=1.5 in., 03=3 in., 04=4 in., 06=6 in.
- Bottom style: S= solid

Part numbering system

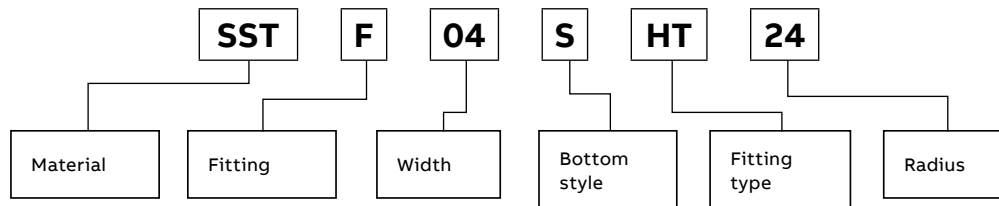

Channel tray fittings

Horizontal cross fittings

Horizontal cross

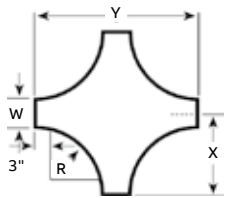

Radius R (in.)	Width W (in.)	Cat. no.	Dimensions (in.)	
			X	Y
12	1.5	(Prefix)-F 01-S-HX-12	15¾	31½
12	3	(Prefix)-F 03-S-HX-12	16½	33
12	4	(Prefix)-F 04-S-HX-12	17	34
12	6	(Prefix)-F 06-S-HX-12	18	36
24	1.5	(Prefix)-F 01-S-HX-24	27¾	55½
24	3	(Prefix)-F 03-S-HX-24	28½	57
24	4	(Prefix)-F 04-S-HX-24	29	58
24	6	(Prefix)-F 06-S-HX-24	30	60

*Specify prefixes ALT, SPT, SHT or SST

Selection guide

- Prefix: ALT (alum.), SPT (pregalv.), SHT (hot-dip galv.), SST (stainless steel)
- Inside channel widths: 01=1.5 in., 03=3 in., 04=4 in., 06=6 in.
- Bottom style: S= solid

Part numbering system

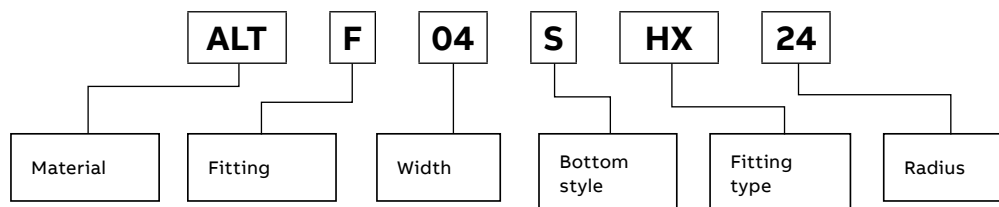

Channel tray fittings

90° Vertical outside/inside bend fittings

90° Vertical outside bend



	Radius R (in.)	Width W (in.)	Cat. no.	Dimensions (in.)	
				X	Y
	12	1.5	(Prefix)-F 01-S-VO90-12	15	15
	12	3	(Prefix)-F 03-S-VO90-12	15	15
	12	4	(Prefix)-F 04-S-VO90-12	15	15
	12	6	(Prefix)-F 06-S-VO90-12	15	15
	24	1.5	(Prefix)-F 01-S-VO90-24	15	15
	24	3	(Prefix)-F 03-S-VO90-24	27	27
	24	4	(Prefix)-F 04-S-VO90-24	27	27
	24	6	(Prefix)-F 06-S-VO90-24	27	27

*Specify prefixes ALT, SPT, SHT or SST

90° Vertical inside bend



	Radius R (in.)	Width W (in.)	Cat. no.	Dimensions (in.)	
				X	Y
	12	1.5	(Prefix)-F 01-S-VI90-12	15¾	15¾
	12	3	(Prefix)-F 03-S-VI90-12	16½	16½
	12	4	(Prefix)-F 04-S-VI90-12	16¾	16¾
	12	6	(Prefix)-F 06-S-VI90-12	16¾	16¾
	24	1.5	(Prefix)-F 01-S-VI90-24	27¾	27¾
	24	3	(Prefix)-F 03-S-VI90-24	28½	28½
	24	4	(Prefix)-F 04-S-VI90-24	28¾	28¾
	24	6	(Prefix)-F 06-S-VI90-24	28¾	28¾

*Specify prefixes ALT, SPT, SHT or SST

90° Outside bend

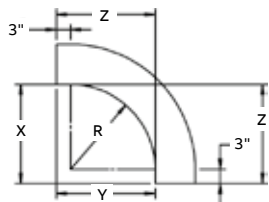

90° Inside bend

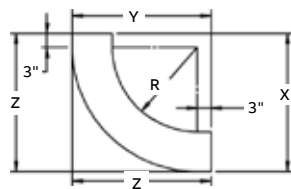

Selection guide

- Prefix: ALT (alum.), SPT (pregalv.), SHT (hot-dip galv.), SST (stainless steel)
- Inside channel widths: 01=1.5 in., 03=3 in., 04=4 in., 06=6 in.
- Bottom style: S= solid

Part numbering system

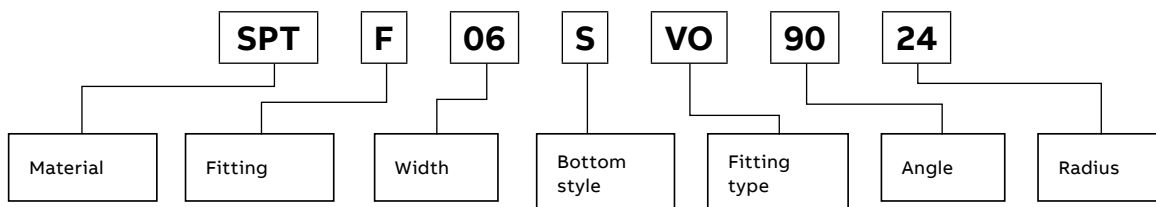

Channel tray fittings

60° Vertical outside/inside bend fittings

60° Vertical outside bend



	Radius R (in.)	Width W (in.)	Cat. no.	Dimensions (in.)		
				X	Y	Z
	12	1.5	(Prefix)-F 01-S-VO60-12	14 ⁷ / ₈	8 ⁵ / ₈	9 ⁷ / ₈
	12	3	(Prefix)-F 03-S-VO60-12	14 ⁷ / ₈	8 ⁵ / ₈	9 ⁷ / ₈
	12	4	(Prefix)-F 04-S-VO60-12	14 ⁷ / ₈	8 ⁵ / ₈	9 ⁷ / ₈
	12	6	(Prefix)-F 06-S-VO60-12	14 ⁷ / ₈	8 ⁵ / ₈	9 ⁷ / ₈
	24	1.5	(Prefix)-F 01-S-VO60-24	25 ³ / ₄	14 ⁵ / ₈	16 ⁷ / ₈
	24	3	(Prefix)-F 03-S-VO60-24	25 ³ / ₄	14 ⁵ / ₈	16 ⁷ / ₈
	24	4	(Prefix)-F 04-S-VO60-24	25 ³ / ₄	14 ⁵ / ₈	16 ⁷ / ₈
	24	6	(Prefix)-F 06-S-VO60-24	25 ³ / ₄	14 ⁵ / ₈	16 ⁷ / ₈

*Specify prefixes ALT, SPT, SHT or SST

60° Vertical inside bend



	Radius R (in.)	Width W (in.)	Cat. no.	Dimensions (in.)		
				X	Y	Z
	12	1.5	(Prefix)-F 01-S-VI60-12	15 ¹ / ₂	9	10 ³ / ₄
	12	3	(Prefix)-F 03-S-VI60-12	16 ¹ / ₈	9 ³ / ₄	10 ³ / ₄
	12	4	(Prefix)-F 04-S-VI60-12	16 ¹ / ₄	9 ³ / ₈	10 ⁷ / ₈
	12	6	(Prefix)-F 06-S-VI60-12	16 ¹ / ₈	9 ¹ / ₂	11
	24	1.5	(Prefix)-F 01-S-VI60-24	26	15	17 ³ / ₄
	24	3	(Prefix)-F 03-S-VI60-24	26 ¹ / ₂	15 ³ / ₄	17 ³ / ₈
	24	4	(Prefix)-F 04-S-VI60-24	26 ³ / ₄	15 ⁵ / ₈	17 ³ / ₄
	24	6	(Prefix)-F 06-S-VI60-24	26 ³ / ₄	15 ¹ / ₂	17 ⁷ / ₈

*Specify prefixes ALT, SPT, SHT or SST

60° Outside bend

60° Inside bend

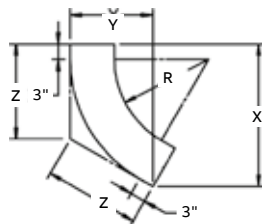
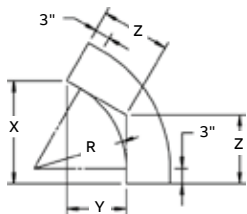

Selection guide

- Prefix: ALT (alum.), SPT (pregalv.), SHT (hot-dip galv.), SST (stainless steel)
- Inside channel widths: 01=1.5 in., 03=3 in., 04=4 in., 06=6 in.
- Bottom style: S= solid

Part numbering system

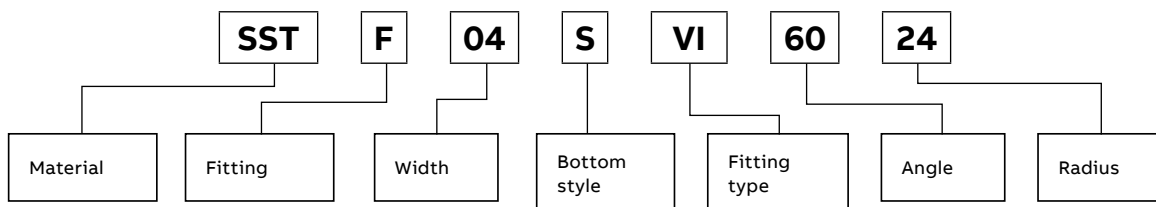

Channel tray fittings

45° Vertical outside/inside bend fittings

45° Vertical outside bend



Radius R (in.)	Width W (in.)	Cat. no.	Dimensions (in.)		
			X	Y	Z
12	1.5	(Prefix)-F 01-S-VO45-12	13 ³ / ₈	5 ⁵ / ₈	8
12	3	(Prefix)-F 03-S-VO45-12	13 ³ / ₈	5 ⁵ / ₈	8
12	4	(Prefix)-F 04-S-VO45-12	13 ³ / ₈	5 ⁵ / ₈	8
12	6	(Prefix)-F 06-S-VO45-12	13 ³ / ₈	5 ⁵ / ₈	8
24	1.5	(Prefix)-F 01-S-VO45-24	22 ¹ / ₈	9 ¹ / ₈	12 ⁷ / ₈
24	3	(Prefix)-F 03-S-VO45-24	22 ¹ / ₈	9 ¹ / ₈	13
24	4	(Prefix)-F 04-S-VO45-24	11	11	13
24	6	(Prefix)-F 06-S-VO45-24	11	11	13

*Specify prefixes ALT, SPT, SHT or SST

45° Vertical inside bend



Radius R (in.)	Width W (in.)	Cat. no.	Dimensions (in.)		
			X	Y	Z
12	1.5	(Prefix)-F 01-S-VI45-12	13 ³ / ₈	5 ⁵ / ₈	8
12	3	(Prefix)-F 03-S-VI45-12	13 ³ / ₈	5 ⁵ / ₈	8
12	4	(Prefix)-F 04-S-VI45-12	13 ³ / ₈	5 ⁵ / ₈	8
12	6	(Prefix)-F 06-S-VI45-12	13 ³ / ₈	5 ⁵ / ₈	8
24	1.5	(Prefix)-F 01-S-VI45-24	22 ¹ / ₈	9 ¹ / ₈	12 ⁷ / ₈
24	3	(Prefix)-F 03-S-VI45-24	22 ¹ / ₈	9 ¹ / ₈	13
24	4	(Prefix)-F 04-S-VI45-24	11	11	13
24	6	(Prefix)-F 06-S-VI45-24	11	11	13

*Specify prefixes ALT, SPT, SHT or SST

45° Outside bend

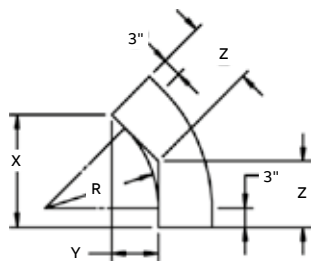

45° Inside bend

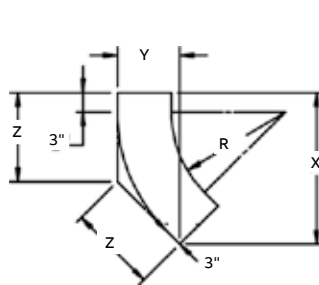

Selection guide

- Prefix: ALT (alum.), SPT (pregalv.), SHT (hot-dip galv.), SST (stainless steel)
- Inside channel widths: 01=1.5 in., 03=3 in., 04=4 in., 06=6 in.
- Bottom style: S= solid

Part numbering system

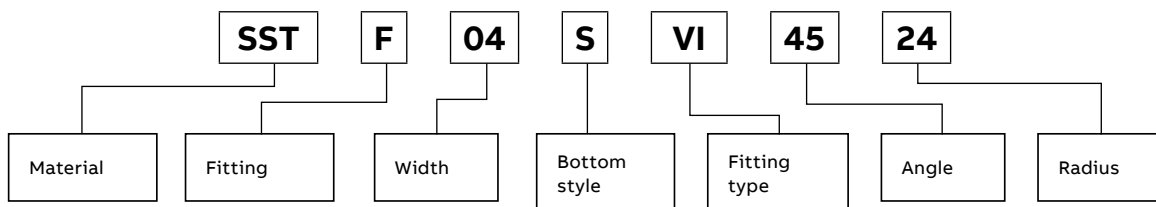

Channel tray fittings

30° Vertical outside/inside bend fittings

30° Vertical outside bend



Radius R (in.)	Width W (in.)	Cat. no.	Dimensions (in.)		
			X	Y	Z
12	1.5	(Prefix)-F 01-S-VO30-12	10 ³ / ₈	1 ¹ / ₈	5 ¹ / ₄
12	3	(Prefix)-F 03-S-VO30-12	11 ⁵ / ₈	3 ³ / ₈	6 ³ / ₈
12	4	(Prefix)-F 04-S-VO30-12	11 ⁵ / ₈	3 ³ / ₈	6 ³ / ₈
12	6	(Prefix)-F 06-S-VO30-12	11 ⁵ / ₈	3 ³ / ₈	6 ³ / ₈
24	1.5	(Prefix)-F 01-S-VO30-24	17 ⁷ / ₈	4 ³ / ₄	9 ¹ / ₂
24	3	(Prefix)-F 03-S-VO30-24	17 ⁷ / ₈	4 ³ / ₄	9 ¹ / ₄
24	4	(Prefix)-F 04-S-VO30-24	17 ⁷ / ₈	4 ³ / ₄	9 ¹ / ₄
24	6	(Prefix)-F 06-S-VO30-24	17 ⁷ / ₈	4 ³ / ₄	9 ¹ / ₄

*Specify prefixes ALT, SPT, SHT or SST

30° Vertical inside bend

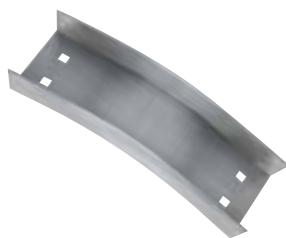

Radius R (in.)	Width W (in.)	Cat. no.	Dimensions (in.)		
			X	Y	Z
12	1.5	(Prefix)-F 01-S-VI30-12	10 ³ / ₈	1 ¹ / ₈	5 ³ / ₈
12	3	(Prefix)-F 03-S-VI30-12	12 ¹ / ₄	3 ¹ / ₂	6 ³ / ₈
12	4	(Prefix)-F 04-S-VI30-12	12 ³ / ₈	3 ³ / ₈	5 ⁵ / ₈
12	6	(Prefix)-F 06-S-VI30-12	12 ¹ / ₂	3 ³ / ₈	5 ⁵ / ₈
24	1.5	(Prefix)-F 01-S-VI30-24	18	4 ³ / ₄	9 ⁵ / ₈
24	3	(Prefix)-F 03-S-VI30-24	18 ¹ / ₄	4 ⁷ / ₈	9 ³ / ₄
24	4	(Prefix)-F 04-S-VI30-24	18 ³ / ₈	4 ⁷ / ₈	9 ⁷ / ₈
24	6	(Prefix)-F 06-S-VI30-24	18 ¹ / ₂	5	9 ⁷ / ₈

*Specify prefixes ALT, SPT, SHT or SST

30° Outside bend

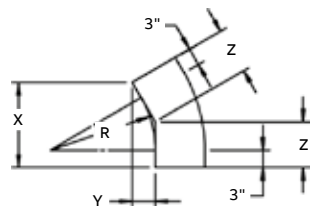

30° Inside bend

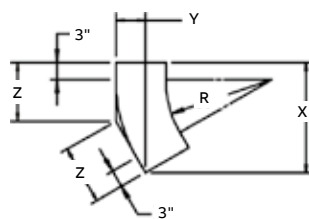

Selection guide

- Prefix: ALT (alum.), SPT (pregalv.), SHT (hot-dip galv.), SST (stainless steel)
- Inside channel widths: 01=1.5 in., 03=3 in., 04=4 in., 06=6 in.
- Bottom style: S= solid

Part numbering system

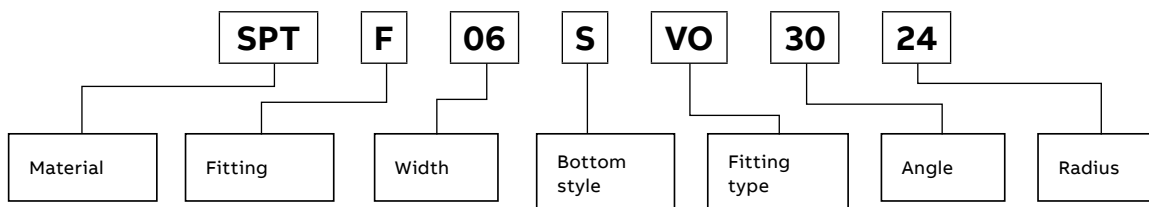

Channel tray covers

Cover selection guide

—
Cover mounting hardware must be ordered separately.



Tray covers

Tray covers are available for all widths of tray. They should be installed where falling objects may damage cables or where vertical tray run is accessible by pedestrian or vehicular traffic.

Straight covers

- These covers provide maximum mechanical protection for cables with limited heat build up
- Flanged covers have ½ in. flange

Quantity of standard cover clamps required

Straight section (10 ft.)	6 pcs.
---------------------------	--------

NOTE: When using the heavy-duty cover clamps, only half the quantity of pieces are required.



Straight cover number selection

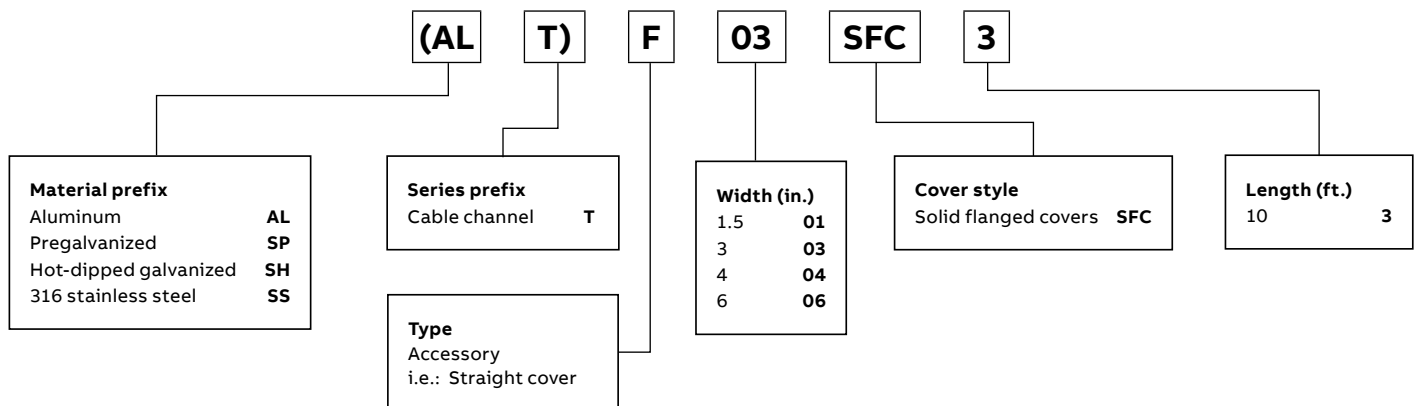

—
* Hot-dipped galvanized covers only available in 1500 mm lengths.

—
Cover mounting hardware must be ordered separately.



—
Fitting covers

- Fitting covers are available to complete your cable channel layout
- All fitting covers are flanged

Quantity of standard cover clamps required

Horizontal and vertical bends	4 pcs.
Tees	6 pcs.
Crosses	8 pcs.

Note: When using the heavy-duty cover clamps, only half the quantity of pieces are required.



—
Fittings cover number selection

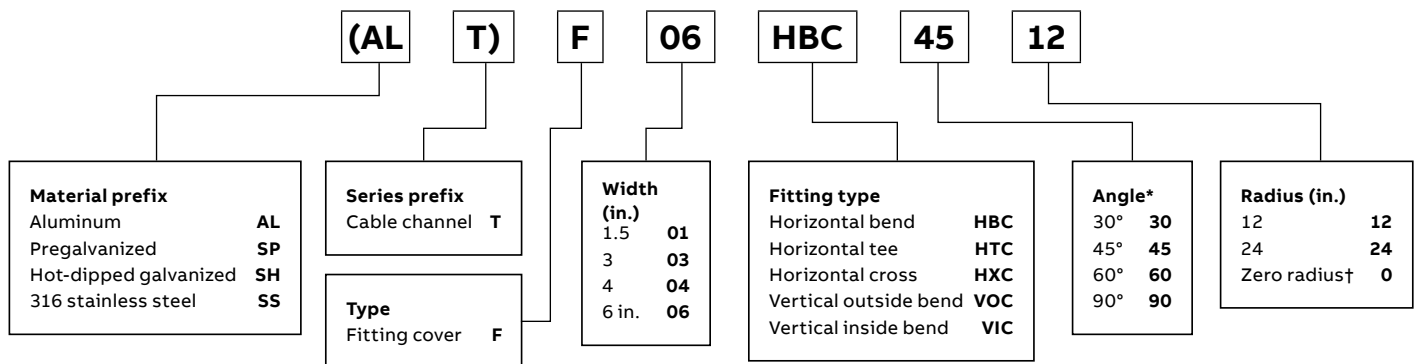

—
*Required for HB, VI and VO only.

† Contact your regional sales office for availability.

Channel tray splice plates

Standard and expansion splice plates

Selection guide

- Prefix: ALT (alum.), SPT (pregalv.), SHT (hot-dip galv.), SST (stainless steel)
- Inside channel widths: 01=1.5 in., 03=3 in., 04=4 in., 06=6 in.



Standard 1.5 in. splice plate

	Cat. no.	Width (in.)
	(Prefix)-W-01-CCS	1.5

Supplied standard with each length.
Including hardware: 2 bolts, 2 washers, $\frac{3}{8}$ in. diameter.

Standard splice plate

	Cat. no.	Width (in.)
	(Prefix)-W-03-CCS	3
	(Prefix)-W-04-CCS	4
	(Prefix)-W-06-CCS	6

Supplied standard with each length.
Including hardware: 4 bolts, 4 nuts, 4 washers, $\frac{3}{8}$ in. diameter.

Expansion splice plate

	Cat. no.	Width (in.)
	(Prefix)-W-01-ESP	1.5
	(Prefix)-W-03-ESP	3
	(Prefix)-W-04-ESP	4
	(Prefix)-W-06-ESP	6

Supplied with hardware for 1.5 in. wide channel: 2 bolts, 2 nuts; all other widths: 4 bolts, 2 stop nuts, 2 serrated flange nuts, 4 lock washers (stainless steel only), $\frac{3}{8}$ in. diameter.

Channel tray splice plates

Wraparound and adjustable splice plates

Selection guide

- Prefix: ALT (alum.), SPT (pregalv.), SHT (hot-dip galv.), SST (stainless steel)
- Inside channel widths: 01=1.5 in., 03=3 in., 04=4 in., 06=6 in.

Wraparound splice plate



Cat. no.	Width (in.)
(Prefix)-W-01-ACS	1.5
(Prefix)-W-03-ACS	3
(Prefix)-W-04-ACS	4
(Prefix)-W-06-ACS	6

Supplied with hardware for 1.5 in. wide channel: 2 bolts, 2 nuts; all other widths: 4 bolts, 4 nuts, 4 washers, $\frac{3}{8}$ in. diameter.



Adjustable horizontal splice plate



Cat. no.	Width (in.)
(Prefix)-W-01-CHA	1.5
(Prefix)-W-03-CHA	3
(Prefix)-W-04-CHA	4
(Prefix)-W-06-CHA	6

Standard vertical adjustable splice plate



Cat. no.	Width (in.)
(Prefix)-W-01-CCV	1.5
(Prefix)-W-03-CCV	3
(Prefix)-W-04-CCV	4
(Prefix)-W-06-CCV	6

Channel tray clamps and hardware

Wraparound splice plates and clamps

Selection guide

- Prefix: ALT (alum.), SPT (pregalv.), SHT (hot-dip galv.), SST (stainless steel)
- Inside channel widths: 01=1.5 in., 03=3 in., 04=4 in., 06=6 in.

Wraparound vertical adjustable splice plate

	Cat. no.	Width (in.)
	(Prefix)-W-01-WAV	1.5
	(Prefix)-W-03-WAV	3
	(Prefix)-W-04-WAV	4
	(Prefix)-W-06-WAV	6

Standard hold-down clamp

	Cat. no.	Width (in.)
	(Prefix)-W-01-SHC	1.5
	(Prefix)-W-03-SHC	3
	(Prefix)-W-04-SHC	4
	(Prefix)-W-06-SHC	6

Channel expansion guide clamp



	Cat. no.	Width (in.)
	(Prefix)-W-01-CEG	1.5
	(Prefix)-W-03-CEG	3
	(Prefix)-W-04-CEG	4
	(Prefix)-W-06-CEG	6

Combination hold-down/cover clamp

	Cat. no.	Width (in.)
	(Prefix)-W-01-CCC	1.5
	(Prefix)-W-03-CCC	3
	(Prefix)-W-04-CCC	4
	(Prefix)-W-06-CCC	6

Channel tray clamps and hardware

Cover clamps, end plates and channel brackets

Selection guide

- Prefix: ALT (alum.), SPT (pregalv.), SHT (hot-dip galv.), SST (stainless steel)
- Inside channel widths: 01=1.5 in., 03=3 in., 04=4 in., 06=6 in.

Heavy-duty cover clamp



Cat. no.	Width (in.)
(Prefix)-W-01-HCC	1.5
(Prefix)-W-03-HCC	3
(Prefix)-W-04-HCC	4
(Prefix)-W-06-HCC	6

Closed end plate



Cat. no.	Width (in.)
(Prefix)-W-01-CEP	1.5
(Prefix)-W-03-CEP	3
(Prefix)-W-04-CEP	4
(Prefix)-W-06-CEP	6

Channel-mounting bracket



Cat. no.	Width (in.)
(Prefix)-W-01-CCB	1.5
(Prefix)-W-03-CCB	3
(Prefix)-W-04-CCB	4
(Prefix)-W-06-CCB	6

Channel-to-cable-tray plate



Cat. no.	Width (in.)
(Prefix)-W-01-CCT	1.5
(Prefix)-W-03-CCT	3
(Prefix)-W-04-CCT	4
(Prefix)-W-06-CCT	6

Channel tray brackets and hangers

Reducer plates, base plates, mounting brackets and hangers

Selection guide

- Prefix: ALT (alum.), SPT (pregalv.), SHT (hot-dip galv.), SST (stainless steel)
- Inside channel widths: 01=1.5 in., 03=3 in., 04=4 in., 06=6 in.

Channel straight reducer plate



Cat. no.	Width (in.)
(*)-W-03-01-RSP	3 to 1
(*)-W-04-01-RSP	4 to 1
(*)-W-06-01-RSP	6 to 1
(*)-W-04-03-RSP	4 to 3
(*)-W-06-03-RSP	6 to 3
(*)-W-06-04-RSP	6 to 4

Channel-to-floor base plate



Cat. no.	Width (in.)
(Prefix)-W-01-CBP	1.5
(Prefix)-W-03-CBP	3
(Prefix)-W-04-CBP	4
(Prefix)-W-06-CBP	6

Single channel hanger



Cat. no.	Width (in.)
SPT-W-06-CCH	For use with all widths
SHT-W-06-CCH	For use with all widths
SST-W-06-CCH	For use with all widths

Designed for use with 1/2 in. threaded rod

Channel tray brackets and hangers

Hangers and channel rubber edge trim



- Product specifications: Recommended temperature range: -40 °C through 107 °C
- Recommended temperature range if ordered with adhesive: -23 °C through 70 °C
- Base material: Dense neoprene rubber
- Very flexible to fit tight radius
- Wear- and fuel-resistant neoprene
- Available on request with pre-applied butyl sealant or hot-melted adhesive

Double channel hanger

	Cat. no.	Width (in.)
	SPT-W-06-DCH	For use with all widths
	SHT-W-06-DCH	For use with all widths

Designed for use with ½ in. threaded rod

Channel rubber edge trim

	Cat. no.	Width	Description
	RET-BUSH	For use with 3 in., 4 in. and 6 in.	Rubber edge trim – 10¾ in. bushing – standard pack of 10
	RET-50	For use with all widths	Rubber edge trim – 50 foot roll
	RET-500	For use with all widths	Rubber edge trim – 500 foot roll

Ice and wind loading maps

Figure 250-1USA and 250-2USA loading for grades B, C and D

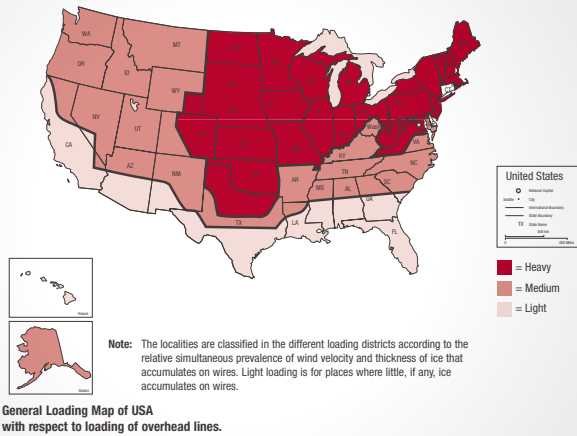

01

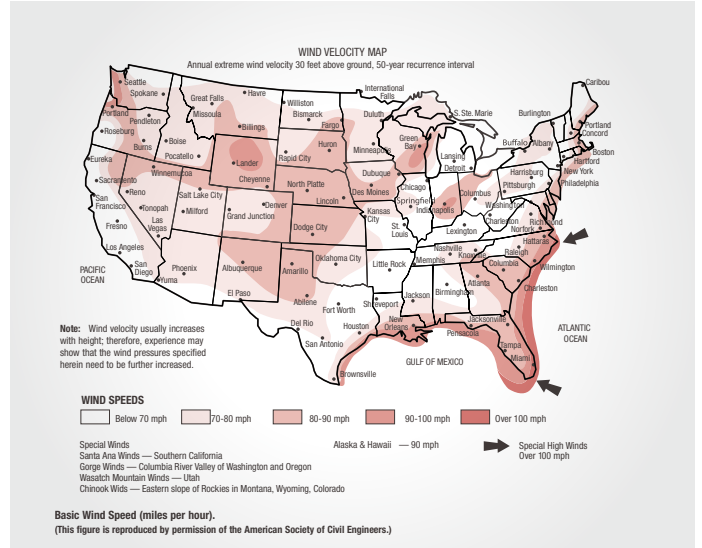

02

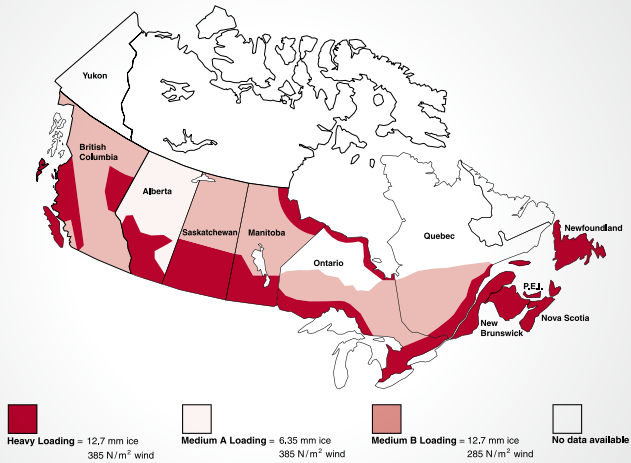

03

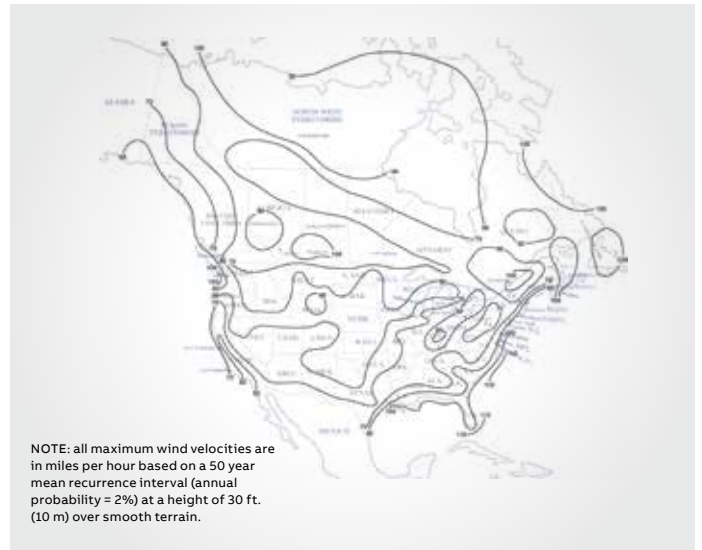

04

01 General loading map of USA with respect to loading of overhead lines.

02 Basic wind speed (miles per hour) – USA.

03 General loading map of Canada with respect to loading of overhead lines.

04 Basic wind speed (miles per hour) – Canada.

Figure 250-2CDN is a wind map of North America reproduced from ASCE 7-88 [52]. For Hawaii and Puerto Rico, the basic wind speeds are 80 mph and 95 mph, respectively.

Note: Wind velocity usually increases with height; therefore, experience may show that the wind pressures specified herein need to be further increased.