



## RGC Series

Steel, compact, 6 and 12V



### FEATURES

- Compact steel cabinet with corrosion-resistant undercoating
- Quick and easy installation – pre-assembled cordset, no batteries or board to remove before installation
- Universal Spider knockout pattern for junction box mounting
- Fully automatic solid-state charger with test switch and AC-on pilot light
- Sealed dust-proof transfer relay circuit and low-voltage disconnect
- Long-life, maintenance-free sealed Lead-Acid battery
- Heads require no tools for orientation
- Standard input 120VAC with line cord installed
- 120/347VAC without line cord
- Auto-testing capabilities (specific load requirements)
- Meets or exceeds CSA C22.2 No. 141-15

See warranty details at: [www.tnb.ca/en/brands/lumacell](http://www.tnb.ca/en/brands/lumacell)

### TYPICAL SPECIFICATIONS

The contractor shall install the Lumacell® RGC Series battery units. The emergency lighting system shall consist of fully automatic equipment with two emergency lighting heads. The unit shall be rated \_\_\_\_ V with a capacity of \_\_\_\_ W for 30 minutes of emergency operation. The charger shall be factory set with a charging voltage tolerance of  $\pm 1\%$  to enable a longer battery life. The emergency light heads shall require no tools for adjusting or aiming. The metal cabinet shall be made of steel with anti-corrosion undercoating. The unit equipped with the auto-test micro-controller board shall self-test 1 minute every 30 days, 10 minutes in the 6th month and 30 minutes every 12 months. The unit shall be supplied with a test switch and diagnostic LED indicator lights to continuously monitor the status of the unit: Battery Failure, Battery Disconnect, Charger Failure, Lamp Failure, Service Alarm, main voltage AC "ON", Charger High Rate.

The unit shall be CSA 22.2 No.141-15 certified.

The unit shall be Lumacell® model: \_\_\_\_\_ .

### REPLACEMENT LAMPS

ORDERING CODE	TYPE	VOLTAGE/ WATTAGE
580.0097-L	MR16 LED	6V-4W
580.0122-L	MR16 LED	6V-5W
580.0093-L	MR16 LED	12V-4W
580.0104-L	MR16 LED	12V-5W
580.0106-L	MR16 LED	12V-6W

### WIRE GUARDS

460.0080-L	Wall Mount
------------	------------

### POWER CONSUMPTION AND UNIT RATING

MODEL	AC SPECS		WATTAGE CAPACITY				
			30MIN	1H	1H30	2H	4H
RGC27	120/347 VAC	0.06/0.02A	27	15	11	9	-
RGC44		0.18/0.06A	44	26	18	15	7
RGC72		0.19/0.07A	72	42	30	24	12
RG12C44		0.31/0.10A	44	26	18	15	7
RG12C72		0.31/0.10A	72	42	30	24	12

# RGC Series

Steel, compact, 6 and 12V



## DIMENSIONS

Dimensions are approximate and subject to change.

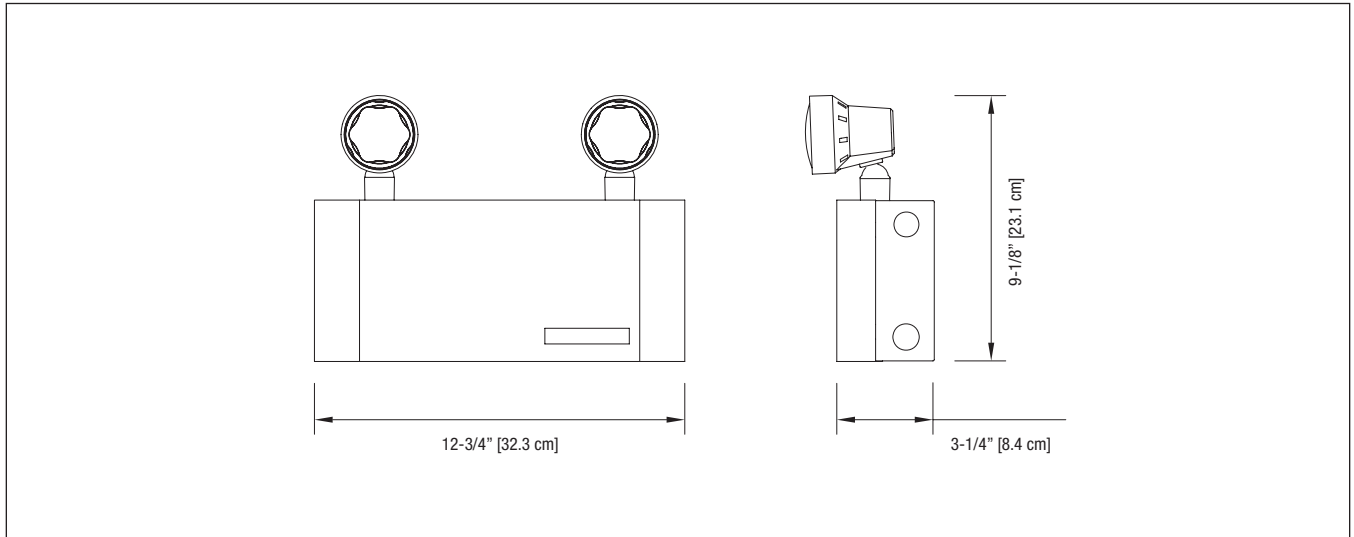

## ORDERING INFORMATION

SERIES	CAPACITY	# OF HEADS	HEAD STYLE/WATTAGE	COLOUR	AC VOLTAGE	OPTIONS
RGC= 6V	27= 27W 44= 44W 72= 72W	Blank= no heads 1= one head 2= two heads	LD1= MR16 LED, 6V-4W LD2= MR16 LED, 6V-5W LD7= MR16 LED, 12V-4W LD9= MR16 LED, 12V-5W LD10= MR16 LED, 12V-6W	Blank= factory white BK= black	Blank= 120VAC c/w line cord ZC= 277VAC input ZD= 120/347VAC input	AT= auto-test <sup>1</sup> ATN= auto-test, non-audible <sup>1</sup> Blank= no options CT= cab-tire NEXRF= wireless NEXUS <sup>®</sup> system interface <sup>2</sup> TL= twistlock plug <sup>3</sup>
RG12C= 12V	44= 44W 72= 72W					

<sup>1</sup>Not available in 6V-72W

<sup>2</sup>Not all options are available with NEXUS<sup>®</sup> system. Please consult your sales representative.

<sup>3</sup>120V is standard

EXAMPLE: RGC272MLD2