

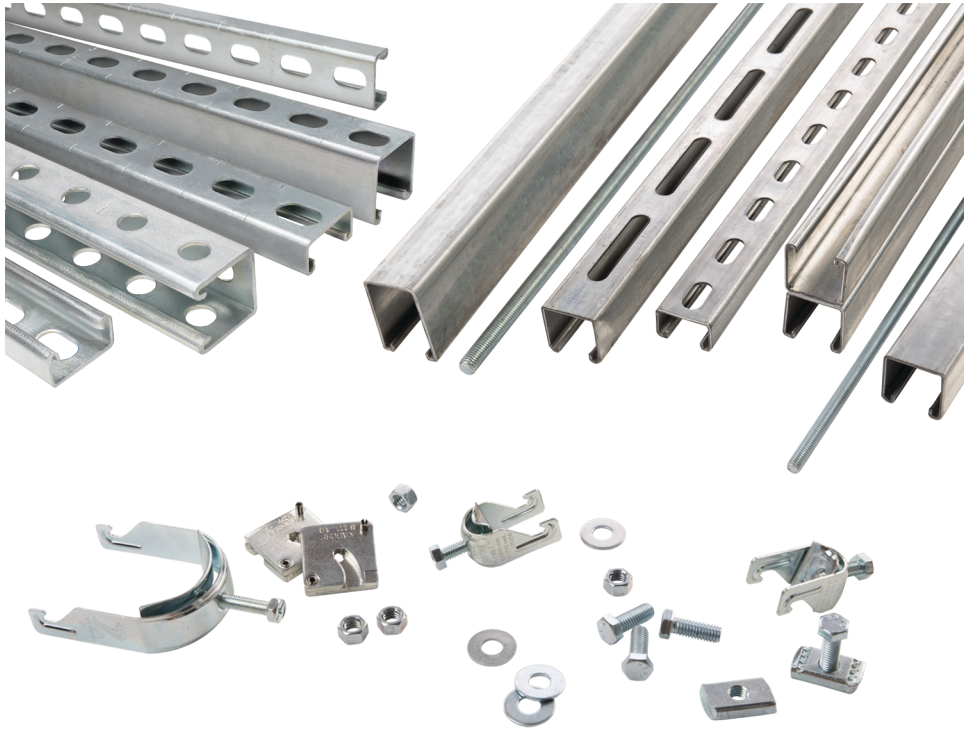

A

# Superstrut® - Metal framing



—  
A

# Superstrut - Metal framing

---

# Table of contents

## Section A

<b>Finishes and materials</b>	A4
<b>Channels and concrete inserts</b>	A5
<b>Threaded products and hardware</b>	A11
<b>Fittings and brackets</b>	A18
<b>Beam clamps</b>	A29
<b>Pipe straps, pipe and conduit clamps and hangers</b>	A38
<b>Hanger accessories</b>	A56
<b>Surface raceway and lighting systems</b>	A57
<b>Right angle slotted metal framing</b>	A64
<b>Engineering data and specifications</b>	A66

---

## Finishes and materials

### Finishes on steel

#### **Bare (suffix B(C))**

#### **Pregalvanized (suffix PG(C))**

A zinc coating is applied to the steel coil at the mill prior to fabrication. Once the material is worked by roll-forming, cutting or punching, minimal protection is provided for raw edges. This weakness is typical with precoated material and affects the channel section around holes, extreme ends and the edges of the U-shape lips. Superstrut pregalvanized material is in conformance with ASTM A-525/G-90 specification standards, representing 0.90 oz. of zinc per square foot of steel. This finish is often referred to as “mill galvanized.”

#### **Electrogalvanized (suffix EG(C))**

Often referred to as “zinc plated” or “electroplated zinc,” the steel and 0.5 mils of zinc are bonded by an electrolysis process. Electrogalvanizing is most commonly applied to small fittings, hardware and threaded products.

#### **GoldGalv® (no suffix)**

Gold-coloured zinc dichromate is applied over the zinc, producing a chemically bonded non-porous barrier for protection from moisture and air. This extends the protective life of the zinc, and provides an excellent base for paint, if desired. The GoldGalv hardware finish also provides a low electrical resistance when grounding of the system is required. Superstrut channel and fittings are plated after fabrication, so there are no unprotected edges from cutting or punching. Where field cutting is necessary or scratches occur due to construction handling, you still have the sacrificial protection of the plated zinc to minimize the corrosion of raw edges and prevent spreading.

#### **Hot-dipped galvanized (suffix HDG(C))**

The material is zinc coated after fabrication, providing total product protection on all surfaces. The fabricated channel or fitting is suspended and then dipped into tanks of hot zinc for a prolonged period, creating a coherent bond. The result is superior corrosion resistance as compared to pregalvanized material. Hot-dipped galvanizing is not recommended for threaded products, considering the zinc coating thickness will often disrupt the threads. Superstrut hot-dipped galvanized is in conformance with ASTM Specifications A-123 (formerly A-386) and A-153. This finish is also referred to as “hot-dipped galvanized after fabrication.”

#### **Epoxy powder coated – green, grey or white (suffix GR(C), GY(C), or WH(C))**

Epoxy powder resins are applied electrostatically to the steel after fabrication. Once the material is completely covered with the powder-form epoxy, it proceeds through a 400 °F (204 °C) baking process for 10 minutes, creating a chemical bond. This results in a minimum of 1.5 mil thickness of epoxy coating, providing excellent resistance to chipping or peeling.

### Special materials

#### **Aluminum (suffix AL(C))**

Superstrut channel is available in aluminum. Fittings in HDG finish or fiberglass material are suggested for fastening products.

#### **Stainless steel (suffix SS)**

Superstrut channel is supplied in type 316 (T316L) stainless steel. All fittings and accessories are in 316SS (SS6). Contact your regional sales office for availability.

**ABB reserves the right to change material and finish specifications without notice, to improve its products.**

## Channels and concrete inserts

### Channels

#### Material

Steel channels are cold-roll formed from strip steel. Aluminum and fiberglass channels are extruded profiles.

#### Material thickness

All series 1,200 12 gauge material  
 All series 1,400 14 gauge material  
 All series 1,600 16 gauge ribbed material

#### Standard lengths

Standard lengths for channels are 10 ft. and 20 ft. with a tolerance of  $\pm\frac{1}{8}$  in. Special lengths can be requested; however, minimum quantities may apply. Channels are sold per foot.

#### Warning

**Load tables, charts and design criteria provided in this catalogue are intended as guides only. Selection of proper product, support spacing, erection and placement are the responsibility of the user. When improperly used as tools of erection, pipe hanger products have occasionally failed. To avoid an accident, the user is cautioned to use the product only as it was intended.**

### Concrete inserts

#### Material

Superstrut continuous insert channel is manufactured from 12 gauge hot-rolled strip steel in two basic sizes as follows:

#### Cat. no. A302

1 $\frac{5}{8}$  in. x 1 $\frac{1}{8}$  in.  $\frac{7}{8}$  in. slot

#### Cat. no. B302

1 $\frac{5}{8}$  in. x 1 $\frac{3}{8}$  in.  $\frac{7}{8}$  in. slot

#### Standard lengths

Standard lengths are 10 ft. and 20 ft. Product is supplied with foam filler and end caps to prevent concrete from seeping into channel.

#### Application

For casting into concrete walls, floors or ceilings to provide for attachment anywhere along the continuous slot.

#### Design data

Load ratings as shown have a safety factor of 3 in 3,000 psi hard rock concrete. Where sound concrete does not exist, the load ratings shall not apply. GoldGalv hardware finish is standard for all Superstrut concrete insert products. This is a multi-process finish of electro-plated zinc, followed by gold-coloured zinc dichromate to give excellent corrosion resistance and a superior paint base.

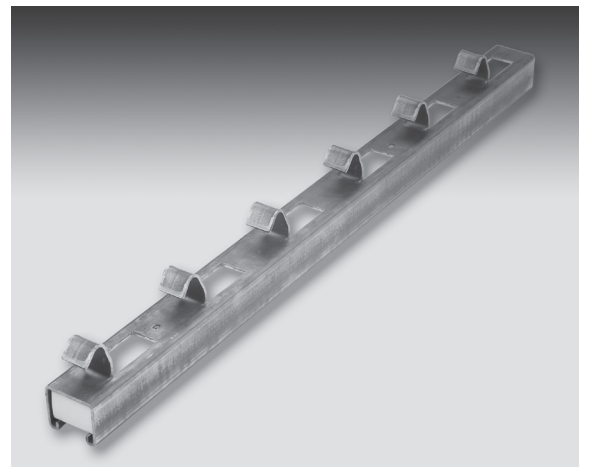
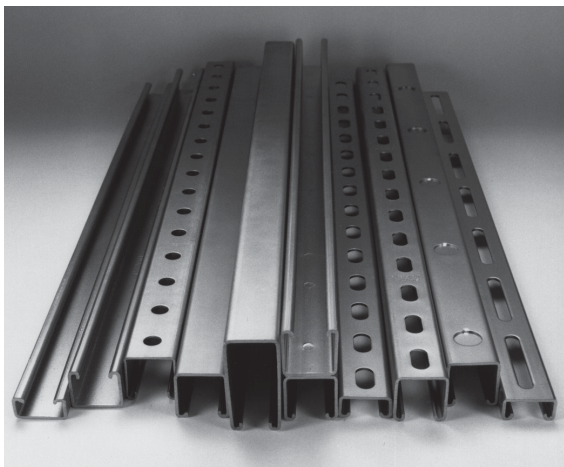

For more information on load design, see page A67 for engineering data and specifications.

# Channels and concrete inserts

Channels at full scale

Available in 10 and 20 foot lengths.

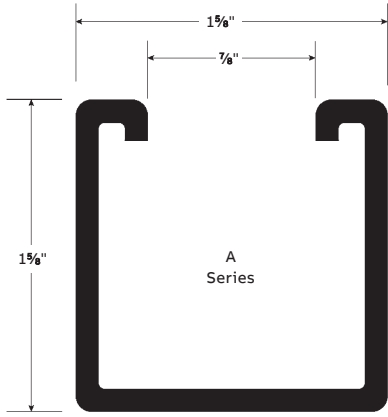

A1200 12 gauge  
A1400 14 gauge

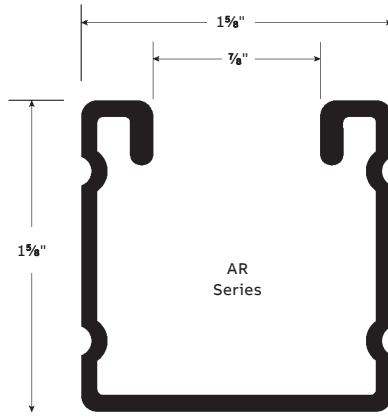

16 gauge only

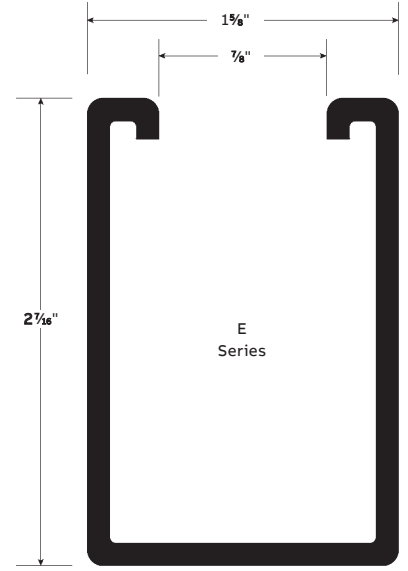

E1200 12 gauge

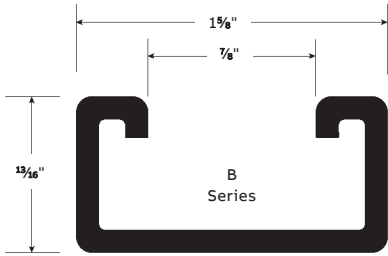

B1200 12 gauge  
B1400 14 gauge

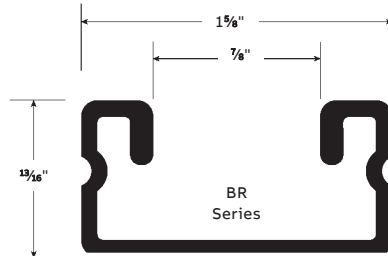

16 gauge only

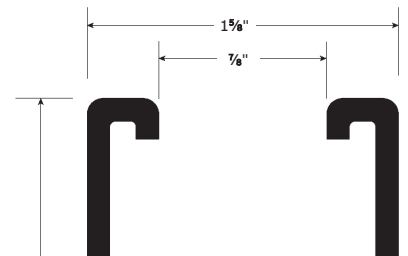

H1200 12 gauge

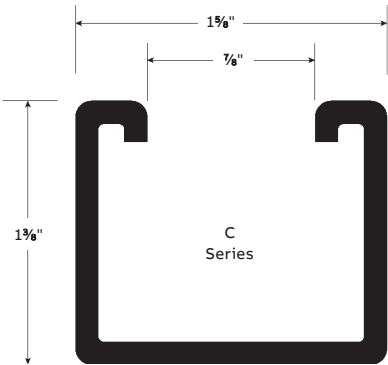

C1200 12 gauge

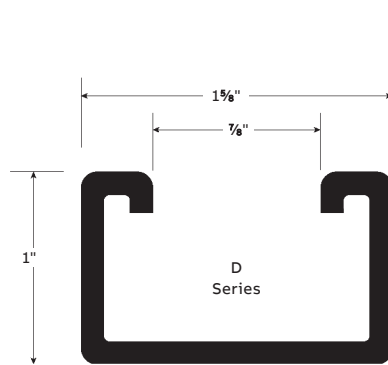

D1200 12 gauge

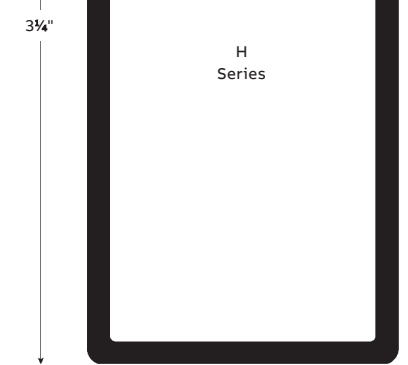

H1200 12 gauge

## Channels and concrete inserts

### Channel selection chart

Channel Series	Hole configurations					Length ft.	Finish on steel					Special materials			
	HS	S	SW	P	KO		B(C)	PG(C)	EG(C)	GoldGalv®	HDG(C)	GR(C),GY(C),WH(C)	AL(C)	T316L	SS6(C)
A1200						10 or 20									
A1400						10 or 20									
AR1600						10 or 20									
B1200						10 or 20									
B1400						10 or 20									
BR1600						10 or 20									
C1200						10 or 20									
D1200						10 or 20									
E1200						10 or 20									
H1200						10 or 20									

### Legend

Examples	Hole configuration		Finish on steel		Special materials	
<b>A120010PG</b> Plain channel, 10 ft., pre-galvanized finish	<b>Suffix</b>	<b>Suffix</b>	<b>Suffix</b>	<b>Suffix</b>		
	Blank	Plain, no holes	B(C)	Bare	AL(C)	Aluminum
	HS	Half slot	PG(C)	Pre-galvanized	SS6(C)	Stainless steel type 316
<b>B1400P10</b> Punched channel, 10 ft., GoldGalv finish	S	Slotted	EG(C)	Electrogalvanized	T316L	Stainless steel type 316L
	SW	Slotted wide	Blank	GoldGalv®		
	P	Punched	HDG(C)	Hot-dipped galvanized		
<b>E1200HS20HDG</b> Half-slot channel, 20 ft., hot-dipped galvanized	KO	Knockout	GR(C),GY(C),WH(C)	Epoxy paint in green (GR)(C), grey (GY)(C) or white (WH)(C)		
		Standard offering		A minimum order quantity may apply		

### Hole configuration

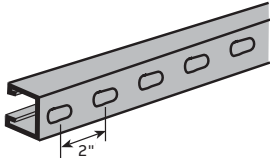
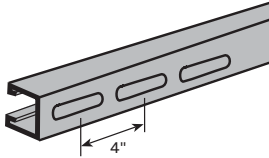
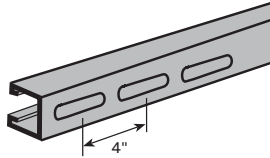
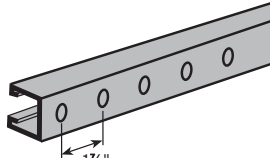
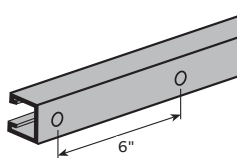
Half-slot channel	Slotted channel	SW "slotted wide" channel	Punched channel	Channel with knockouts
Slots: $\frac{3}{16}$ in. x $1\frac{1}{8}$ in.	Slots: $\frac{7}{16}$ in. x 3 in.	Slots: $\frac{3}{16}$ in. x 3 in.	Holes: $\frac{3}{16}$ in.	KO: $\frac{1}{2}$ in.
				

## Channels and concrete inserts

### Welded combinations

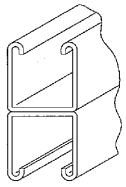

02

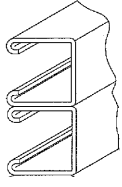

02A

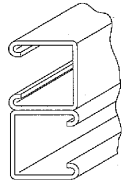

02B

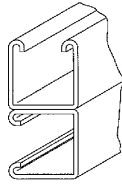

02C

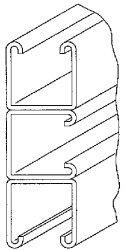

03A

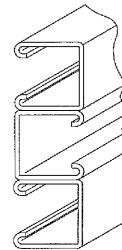

03B

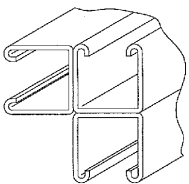

03C

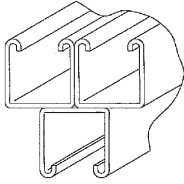

03D

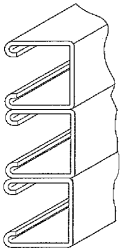

03E

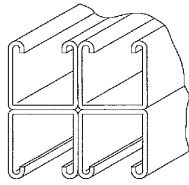

04

### End caps and closure strips

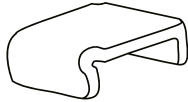

	Cat. no.	For channel	Wt./C lb
A804 End cap	A804EG	A1200	10
		A1400 AR1600	10
	B804EG	B1400 BR1600	5
	C804EG	C1200	8
	E804EG	E1200	15
	H804	H1400	20

### Safety end cap

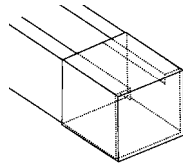

	Cat. no.	For channel	Wt./C lb
1 $\frac{5}{8}$ in. x 1 $\frac{5}{8}$ in. White plastisol	A804NEOPWH	A1200 AR1600	1.75
		A1400	
	B804NEOPWH	B1200 BR1600	5
H804NEOPWH	H1200	2	

#### Examples

Two A1200 channels back to back are ordered as A1202.  
Two A1200 channels back to side are ordered as A1202C.

Aluminum back-to-back channel are extruded profiles.  
All other combinations are spot welded at every 4 inches.  
E and H series are not available in triple and quadruple.



## Channels and concrete inserts

### Welded combinations

—  
01 A243-1EGC End cap  
For A1200 channel  
Wt./C 16 lb

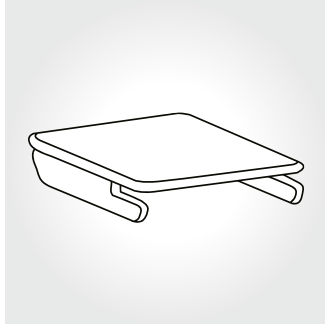

01

—  
02 U-shape support  
A208HDGC  
A208EG  
Does not include  
stud nut or bolts.  
A208 A208SS6C  
For series A and AR.  
Weight/C: 275 lb

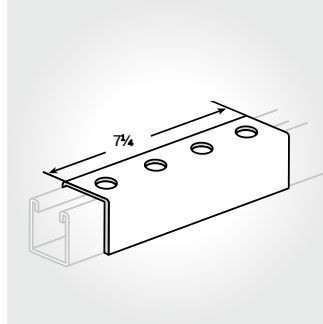

02

—  
03 A213 Inside joiner  
For A1200 series only.  
Available only in  
GoldGalv® finish.

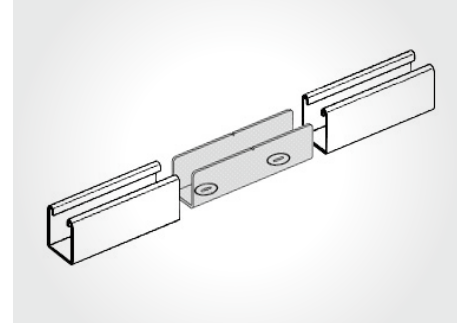

03

—  
04 Pre-galvanized  
steel closure strip  
AB844PGC  
AB844PGCWH  
White epoxy  
powder coated

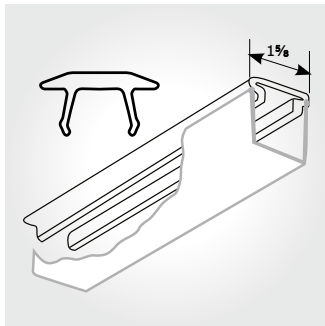

04

Also available in  
ALC (A844)  
Also plastic closure strip  
AB844PC colour: gold  
AB844PCGY  
colour: grey

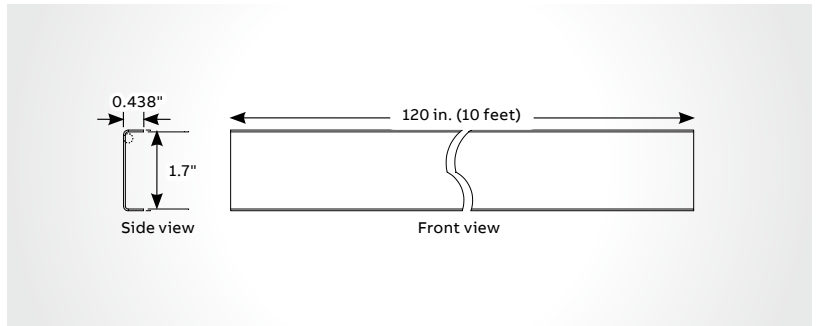

05

—  
05 Stainless steel  
closure strip  
AB844SS6CS (strapping  
not included)

- When used as a raceway, channel is normally installed with the slot up. After wiring has been completed the closure strip is installed.
- For all channels.
- Standard length: 10 ft.

## Channels and concrete inserts

### Concrete inserts

#### SI400 Spot insert kit

Std. pack 10

Cat. no.	Thread size	O.D. insert	Wt./C lb
SI400-3/8	$\frac{3}{8}$ -16	2 x $\frac{5}{16}$	10
SI400-1/2	$\frac{1}{2}$ x 13 x $1\frac{1}{4}$	2 $\frac{1}{2}$ x $\frac{7}{16}$	35

Other sizes available.

Maximum recommended load:

SI400-3/8 = 450 lb/204 kg

SI400-1/2 = 1,000 lb/454 kg

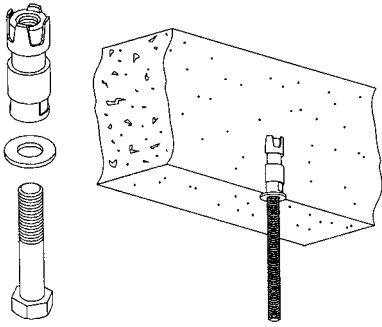

## Threaded products and hardware

### Channel nuts

Superstrut channel nuts are manufactured from grade 2 mild steel and are case hardened.

### Design data

Superstrut self-aligning channel nuts are designed to provide resistance to pullout and resistance to side slip in excess of the full strength of the channels with which they are used. The extreme resistance to side slip results from the unique design of the alternate teeth, spaced and designed to develop a wedging action that increases with pressure or load.

### Screw threads

All threaded products are American Standard thread, free fit class 2.

Thread size (in.)	$\frac{1}{4}$	$\frac{3}{16}$	$\frac{1}{2}$	$\frac{3}{8}$	$\frac{1}{2}$	$\frac{3}{4}$	$\frac{7}{8}$	1
Threads per inch	20	18	16	13	11	10	9	8
Design torque (ft.-lb)	6	11	19	50	100	125	185	275

### Finish and special materials

Standard finish for all hardware is electrogalvanized (EGC) or GoldGalv®. Stainless steel type 316 is also available. Contact your regional sales office for availability and minimum quantities.

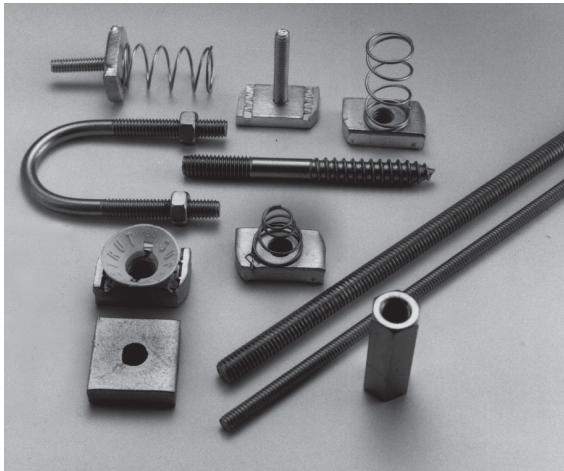

### Spring nut selector chart

Spring nut	Channel series					
	A-AR	B-BR	C	D	E	H
A100-1/4EGC						
A100-5/16EGC						
A100-3/8EGC						
A100-1/2EGC						
A100-3/4						
B100-1/4EGC						
B100-5/16EGC						
B100-3/8EGC						
B100-1/2EGC						
H100-3/8EGC						
H100-1/2EGC						
CM100-1/4						
CM100-3/8						
CM100-1/2						
CM100-1/2B						
UC100-1/4						
UC100-3/8						
UC100-1/2						

## Threaded products and hardware

### A100 Regular spring nut\*

Std. pack 100

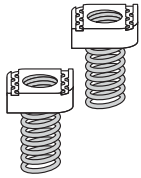

	Cat. No.	Size (in.)	Wt./C lb
	A100-1/4EGC	1/4	8
	A100-5/16EGC	5/16	9
	A100-3/8EGC	3/8	10
	A100-1/2EGC	1/2	12
	A100-5/8EGC	5/8	19
	A100-3/4	3/4	19
	A100-7/8	7/8	18

Available in stainless steel 316. Nut is square over 1/2 in. size.  
For all A and C series channel and inserts.

### AB100 Springless nut 1/4 in. thick

Std. pack 100

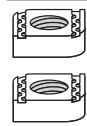

	Cat. no.	Size (in.)	Wt./C lb
	AB100-1/4EGC	1/4	7
	AB100-5/16EGC	5/16	8
	AB100-3/8EGC	3/8	9
	AB100-1/2EG	1/2	9
	AB100-5/8EG	5/8	10
	AB100-3/4EG	3/4	10

For use with all channels. Nut is square over 1/2 in. size.

### H100 Long spring nut\*

Std. pack 100

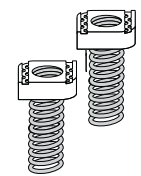

	Cat. no.	Size (in.)	Wt./C lb
	H100-3/8EGC	3/8	10
	H100-1/2EGC	1/2	14

For all E and H series channel and inserts.

### A182 to A185 Regular spring stud nut\*

Std. pack 100

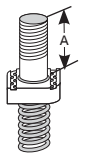

	Cat. no.	Bolt dia (in.)	Length A (in.)	Wt./C lb
Diagram	A182-1/4x100EG	1/4	1	10
	A182-1/4x125EG	1/4	1 1/4	15
	A184-3/8x100EG	3/8	1	10
	A184-3/8x125EG	3/8	1 1/4	15
	A185-1/2x100EG	1/2	1	10
	A185-1/2x125EG	1/2	1 1/4	15

For all A and C series channels.

### B100 Short spring nut\*

Std. pack 100

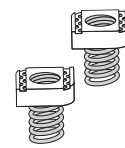

	Cat. no.	Size (in.)	Wt./C lb
	B100-1/4EGC	1/4	7
	B100-5/16EGC	5/16	8
	B100-3/8EGC	3/8	9
	B100-1/2EGC	1/2	9

Available in stainless steel 316.  
For all B and D series channel and inserts.

### AC100 Springless nut heavy-duty 3/8 in. thick

Std. pack 100

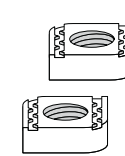

	Cat. no.	Size (in.)	Wt./C lb
	AC100-3/8EGC	3/8	9
	AC100-1/2EGC	1/2	11
	AC100-5/8EGC	5/8	18
	AC100-3/4EGC	3/4	18

For all A, C, E and H series channel and inserts.  
Nut is square over 1/2 in. size.

### A177 to A179 Springless stud nut

Std. pack 100

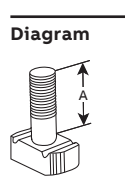

	Cat. no.	Bolt dia (in.)	Length A (in.)	Wt./C lb
Diagram	A177-1/4x100EG	1/4	1	8
	A177-1/4x125EG	1/4	1 1/4	10
	A179-3/8x100EG	3/8	1	13
	A179-3/8x125EG	3/8	1 1/4	13.5

For use with all channels.

### 813EG Springless nut light-duty

Std. pack 100

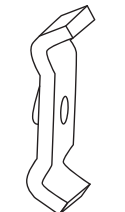

	Cat. no.	Size (in.)	Wt./C lb
	813EG	1/4	5

For use with all channels.

\*Supplied with a plastic sleeve over the spring portion to prevent tangling inside the carton.

## Threaded products and hardware

### E145 Standard hex nut

Std. pack 100

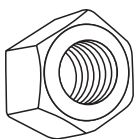

Cat. no.	Size (in.)	Wt./C lb
E145-1/4EGC	1/4	.72
E145-3/8EGC	3/8	1.60
E145-1/2EGC	1/2	2.78
E145-5/8EG	5/8	6.92
E145-3/4EGC	3/4	12.70
E145-7/8EGC	7/8	19.00
E145-1EGC	1	28.00

### 812 Stud nut

Std. pack 100

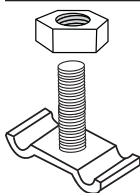

Cat. no.	Size (in.)	Wt./C lb
812-1EG	1/4 x 1	6

For attaching fixture to channel slot down or to channel slot up knockouts. Specify length. Hex nut included.

### UCN Universal nylon cone nut

Std. pack 100

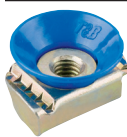

Cat. no.	Size (in.)	Wt./C lb
UCN-1/4	1/4	8
UCN-3/8	3/8	10
UCN-1/2	1/2	12

#### GoldGalv® only

For all 1 1/8 in. and 1 1/2 in. channels.

May be used with ALL strut depths.

Can be used for A100 series, B100 series and AB100 series.

### E147 Flat steel washer

Std. pack 100

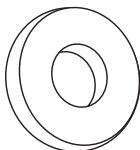

Cat. no.	Size (in.)	Wt./C lb
E147-1/4EG	1/4	0.67
E147-5/16EG	5/16	1.11
E147-3/8EG	3/8	1.49
E147-1/2EG	1/2	3.85
E147-5/8EG	5/8	7.69
E147-3/4EG	3/4	9.89
E147-7/8EG	7/8	15.40

Available in stainless steel.

### ES145 Swivel nut and jam nut combinations

Std. pack 100



Cat. no.	Size (in.)	Wt./C lb
ES145-3/8	3/8	5.5
ES145-1/2	1/2	6.0

### AB102 Unhardened square nut

Std. pack 100

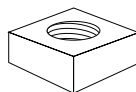

Cat. no.	Size (in.)	Wt./C lb
AB102-1/4	1/4	13
AB102-3/8	3/8	14
AB102-1/2	1/2	14
AB102-5/8	5/8	12
AB102-3/4	3/4	11
AB102-7/8	7/8	10

### E146 Standard square nut

Std. pack 100

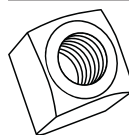

Cat. no.	Size (in.)	Wt./C lb
E146-1/4EG	1/4	.93
E146-5/16EG	5/16	1.60
E146-3/8EGC	3/8	2.65
E146-1/2EG	1/2	5.83
E146-5/8EG	5/8	10.80

### EF147 Fender washer

Std. pack 100

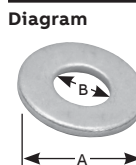

Cat. no.	Size (in.)	A (in.)	B (in.)	Wt./C lb
EF147-1/4EGC	1/4	1 1/4	5/16	3.1
EF147-3/8EGC	3/8	1 1/2	7/16	2.9
EF147-1/2EGC	1/2	2	9/16	5.0

Available in stainless steel.

### E148 Lock washer

Std. pack 100



Cat. no.	Size (in.)	Wt./C lb
E148-1/4EG	1/4	0.26
E148-3/8EG	3/8	0.50
E148-1/2EG	1/2	1.09
E148-5/8EG	5/8	2.57

Available in stainless steel.

## Threaded products and hardware

### E142 Hex head cap screw

Std. pack 100



Cat. no.	Size (in.)	Wt./C lb
E142-1/4x100EG	¼ x 1	1.74
E142-1/4x150EG	¼ x 1½	2.43
E142-3/8x100EG	⅜ x 1	4.17
E142-3/8x150EG	⅜ x 1½	5.64
E142-1/2x100EG	½ x 1	8.94
E142-1/2x150EG	½ x 1½	10.00
E142-1/2x200EG	½ x 2	11.19
E142-1/2x225EG	½ x 2¼	11.90
E142-1/2x250EG	½ x 2½	12.52
E142-1/2x275EG	½ x 2¾	13.22

Available in stainless steel.

### E150S Lag bolt

Std. pack 50

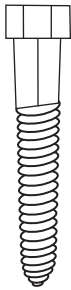

Cat. no.	Drill size (in.)	Size (in.)	Wt./C lb
E150S-3/8x1-1/2EG	¼	⅜ x 1½	5
E150S-3/8x2EG	¼	⅜ x 2	7
E150S-3/8x2-1/2EG	¼	⅜ x 2½	8
E150S-3/8x3EG	¼	⅜ x 3	9
E150S-1/2x1-1/2EG	11/32	½ x 1½	12
E150S-1/2x2EG	11/32	½ x 2	13
E150S-1/2x2-1/2EG	11/32	½ x 2½	15
E150S-1/2x3EG	11/32	½ x 3	18

### H104 Hanger rod continuous threaded

Std. pack 3

- Black available upon request
- Sold per foot; standard length, 10 ft.
- Also available in stainless steel (316) standard length 6 ft. (suffix SS6)
- National coarse thread

Cat. no.	Thread size (in.)	Wt./lb 100 ft.	Design Load lb
H104-1/4x10EGC	¼	12.5	150
H104-3/8x10EGC	⅜	29	610
H104-1/2x10EGC	½	53.5	1,130
H104-5/8x10EGC	⅝	85	1,810
H104-3/4x10EGC	¾	123	2,710
H104-1x10EG	1	214	4,960

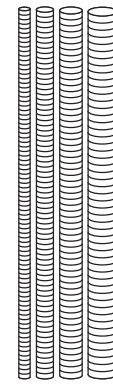

### H119 Rod couplings – standard

Diagram	Rod size	A (in.)	Wt./C lb
	¼	7/8	1.90
	5/16	7/8	3.75
	⅜	1 1/8	3.50
	½	1 1/4	5.50
	5/8	2 1/8	18.00
	¾	2 1/4	28.00
	7/8	2 1/2	55.00
	1	2 3/4	56.00

Standard rod coupling

Example: H119-1/2EG

Order by product number, rod size, and finish.

Available in stainless steel.

### H119 Rod couplings – reducing

Rod size	A (in.)	Wt./C lb
¼ to ⅜	1½	3.50
⅜ to ½	1¼	6.70
½ to ⅝	1¼	14.00
⅝ to ¾	1½	21.00
¾ to 7/8	1¾	40.00

Rod reducer coupling

Example: H119-1/4x3/8EG

## Threaded products and hardware

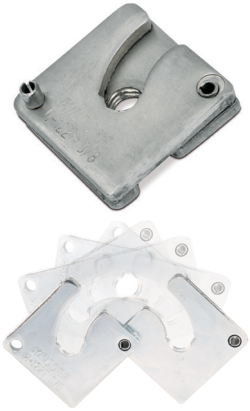

H122 Trapnut™ strut fastener

Cat. no.	Size (in.)	Design load (lb)	Std. ctn.
H 122 1/4	1/4	150	50
H 122 3/8	3/8	590	50
H 122 1/2	1/2	1,080	50
H 122 1/4 EG	1/4	150	50
H 122 3/8 EG	3/8	590	50
H 122 1/2 EG	1/2	1,080	50
H 122 3/8 SS6	3/8	590	50
H 122 1/2 SS6	1/2	1,080	50

Finishes – Electrogalvanized (EG), GoldGalv®, stainless steel type 316 (SS6)

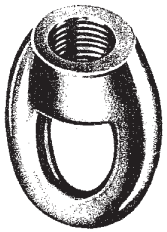

M117 Eye socket

	Rod size A (in.)	Pipe size (in.)	B (in.)	E (in.)	Wt./C lb	Design load, lb
Diagram	1/4	3/8	1/4	1 11/32	5	230
	3/8	1/2–2	1/4	1 11/32	7	610
	1/2	2 1/2–3 1/2	1/4	1 17/32	13	1,130
	5/8	4–5	3/8	1 13/16	19	1,810
	3/4	6	1/2	2 5/32	31	2,400
	7/8	8	1/2	2 11/32	44	2,800

Standard finishes – bare (B), electrogalvanized (EG)  
 Malleable iron. For attaching hanger rod to various types of hangers and beam clamps.  
 Order by product number, rod size, and finish. **Example: M117-1/4B**  
 Complies with Specification MSS SP69, Type 16.

E120 Swivel joint

	Cat. no.	Size (in.)	A (in.)	B (in.)	Wt./C lb	Design load, lb
Diagram	E120-3/8	3/8	1 3/8	3/8	15	1,000
	E120-1/2	1/2	1 1/2	1/2	25	1,800

# Threaded products and hardware

## E120A Weldless eye nut

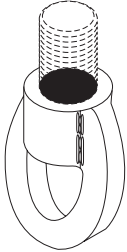

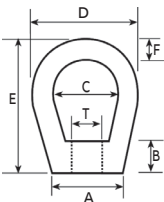
	Rod size T (in.)	A (in.)	B (in.)	C (in.)	D (in.)	E (in.)	F (in.)	Wt./C lb	Design load, lb
Diagram	3/8	7/8	5/8	1 1/4	2	2 1/2	3/8	20	2,700
	1/2	7/8	5/8	1 1/4	2	2 1/2	3/8	22	2,700
	5/8	1 3/8	3/4	1 1/2	2 1/2	3	1/2	60	5,000
	3/4	1 3/8	3/4	1 1/2	2 1/2	3	1/2	56	5,000
	7/8	1 1/2	1 5/8	1 5/16	3 5/8	4 1/2	3/4	174	10,000
	1	1 1/2	1 5/8	1 5/16	3 5/8	4 1/2	3/4	168	10,000

Standard finish – bare (B)  
 Drop forged steel. For use on high temperature piping installations.  
 Order by product number and rod size. **Example: E120A-3/8B**

## E122 Swivel joint

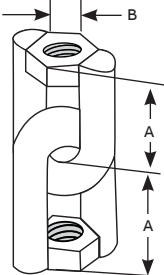
	Cat. no.	Size (in.)	A (in.)	B (in.)	Wt./C lb	Design load, lb
Diagram	E122-3/8	3/8	1 3/8	3/8	28	1,000
	E122-1/2	1/2	1 1/2	1/2	48	1,800

## E130 Swivel joint

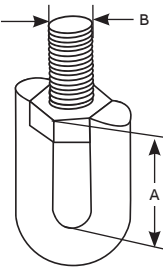
	Cat. no.	Size (in.)	A (in.)	B (in.)	Wt./C lb	Design load, lb
Diagram	E130-3/8	3/8	1 3/8	3/8	23	1,000
	E130-1/2	1/2	1 1/2	1/2	48	1,800

## E131 Swivel joint

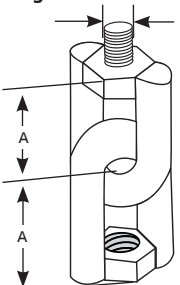
	Cat. no.	Size (in.)	A (in.)	B (in.)	Wt./C lb	Design load, lb
Diagram	E131-3/8	3/8	1 3/8	3/8	25	1,000
	E131-1/2	1/2	1 1/2	1/2	52	1,800



## Threaded products and hardware

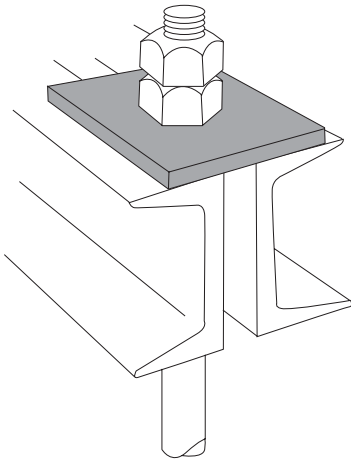

**C781 Square washer**  
Std. pack 50

Cat. no.	Rod size (in.)	Hole size (in.)	Overall dimensions (in.)	Wt./C lb
C781-3/8*	3/8	7/16	3 x 3 x 3/16	27
C781-1/2*	1/2	9/16	3 x 3 x 3/16	27
C781-5/8*	5/8	11/16	3 x 3 x 1/4	47
C781-3/4*	3/4	13/16	3 x 3 x 1/4	42
C781-7/8*	7/8	15/16	4 x 4 x 3/8	85
C781-1*	1	1 1/8	4 x 4 x 3/8	160

Used for beam applications. For channel applications, use AB241.

\*Finishes

- B
- HDG
- EG
- SS6

## Fittings and brackets

### Material

Superstrut fittings and brackets are manufactured from hot rolled carbon steel.

### Dimensions

The following standard dimensions apply to all fittings except as indicated on the individual drawings:

Hole spacing	$1\frac{3}{16}$ in. from end of fittings
Hole spacing	$1\frac{7}{8}$ in. centers
Hole size	$\frac{9}{16}$ in. diameter
Material	$1\frac{5}{8}$ in. wide
Material	$\frac{1}{4}$ in. thick

### Application instructions

Parts drawings illustrate a typical use for the fitting, and in many cases, other uses for the part are appropriate.

### Design data

Load ratings vary depending on whether fittings and brackets are used with 12, 14 or 16 gauge channel. Ratings are shown for each channel material. (See page A66 for engineering data and specifications).

### Nuts and bolts required

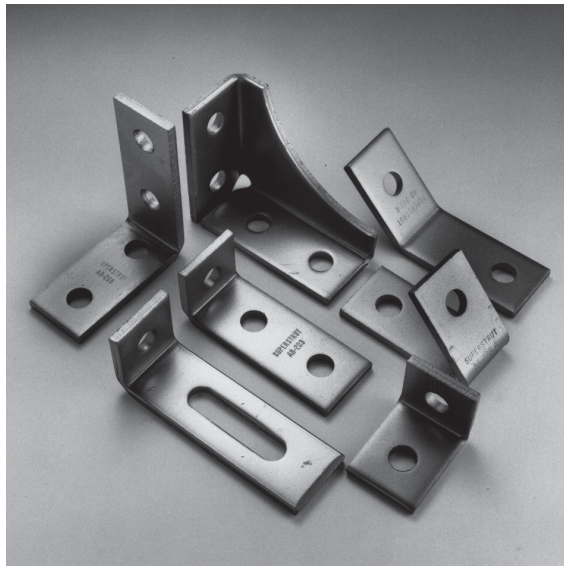

Unless otherwise noted, nuts and bolts for use with fittings and brackets should be ordered separately. The standard bolt for the  $\frac{9}{16}$  in. hole is a  $\frac{1}{2}$  in. hex head cap screw 1 in. long. The 1 in. length may be used with all series channel.

### Design load

For more information on design load, see page A66 for engineering data and specifications.

### Finishes and special materials

Standard finishes are hot-dipped galvanized (HDGC) and GoldGalv® (no suffix). Fittings are also available in electrogalvanized (EG) and stainless steel 316 (SS6C). Contact your regional sales office for availability and minimum quantities.

### Aluminum channel

For aluminum channel, we suggest fittings in HDG (C) or SS6 (C).

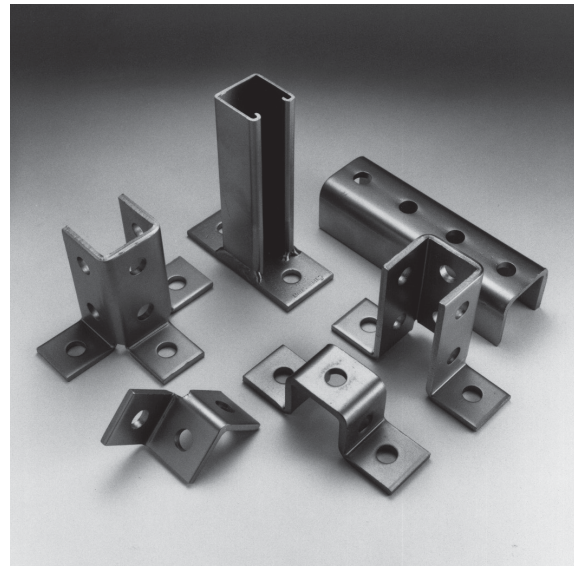

# Fittings and brackets

## Flat fittings

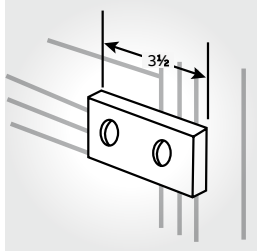

01

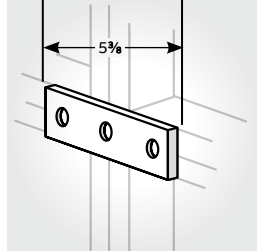

02

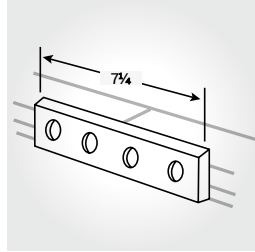

03

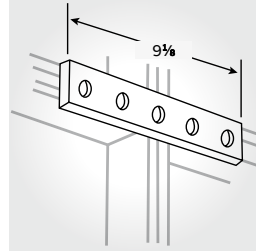

04

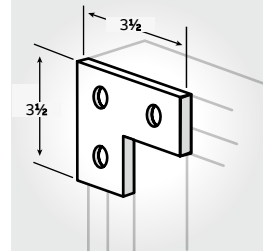

05

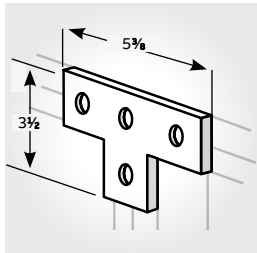

06

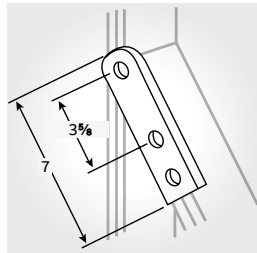

07

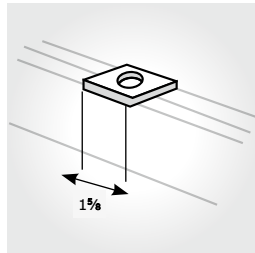

08

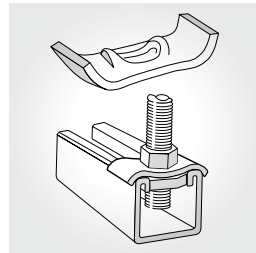

09

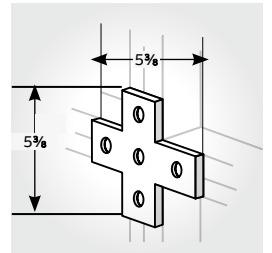

10

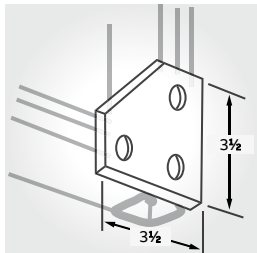

11

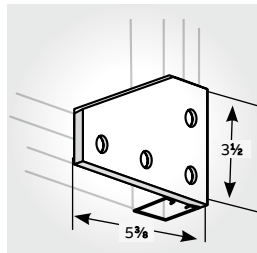

12

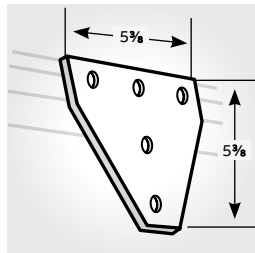

13

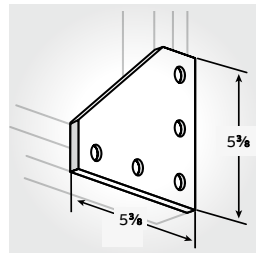

14

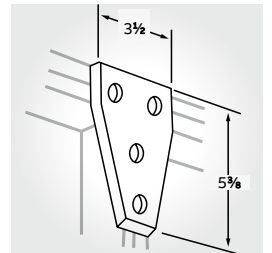

15

01 **AB206**  
AB206HDGC  
AB206EG  
AB206  
AB206SS6C  
Wt./C 35 lb

02 **AB207**  
AB207HDGC  
AB207EG  
AB207  
AB207SS6C  
Wt./C 52 lb

03 **X207**  
X207HDG  
X207EG  
X207  
X207SS6  
Wt./C 78 lb

04 **X208**  
X208HDG  
X208EG  
X208  
X208SS6C  
Wt./C 88 lb

05 **AB219**  
AB219HDGC  
AB219EG  
AB219  
AB219SS6C  
Wt./C 53 lb

06 **AB220**  
AB220HDGC  
AB220EG  
AB220-TB\*  
AB220SS6C  
Wt./C 78 lb

07 **AB240**  
AB240HDG  
AB240EG  
AB240-TB\*  
Wt./C 69 lb

08 **AB241**

Cat. no.	Bolt size (in.)	Wt./C lb
AB241-1/4*	1/4	18
AB241-5/16*	5/16	18
AB241-3/8*	3/8	18
AB241-1/2*	1/2	17
AB241-5/8*	5/8	15
AB241-3/4*	3/4	14

\*Finishes  
• HDGC  
• EG  
• GoldGalv®  
• SS6C

09 **AB242**  
AB242HDGC  
AB242EG  
AB242  
Wt./C 9 lb  
For use with either 3/8 in. or 1/2 in. hanger rod.

10 **AB253**  
AB253HDGC  
AB253EG  
AB253-TB\*  
AB253SS6C  
Wt./C 97 lb

11 **AB255**  
AB255HDGC  
AB255EG  
AB255  
Wt./C 70 lb

12 **AB257**  
AB257HDGC  
AB257EG  
AB257-TB\*  
Wt./C 105 lb

13 **AB261**  
AB261HDGC  
AB261EG  
AB261  
Wt./C 148 lb

14 **AB263**  
AB263HDGC  
AB263EG  
AB263  
AB263SS6  
Wt./C 150 lb

15 **AB265**  
AB265HDGC  
AB265EG  
AB265  
Wt./C 105 lb

### Standard dimensions

Hole spacing	1 3/16 in. from end
Hole spacing	1 7/8 in. centers
Hole size	5/16 in. diam.
Material	1 1/8 in. width
Material	1/4 in. thick

### Materials

HDG(C)	Hot-dipped galvanized
EG(C)	Electrogalvanized
(No suffix)	GoldGalv®
SS6(C)	Stainless steel 316

All dimensions shown are in in.

# Fittings and brackets

## 90° fittings

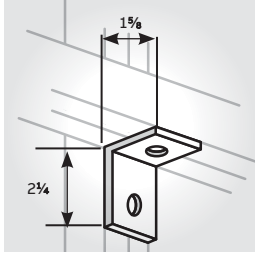

01

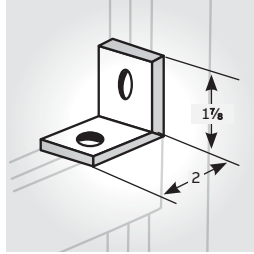

02

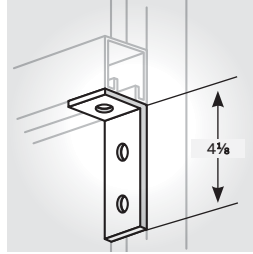

03

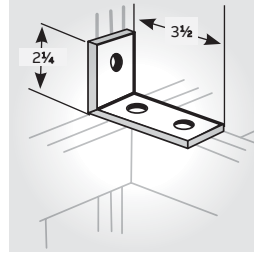

04

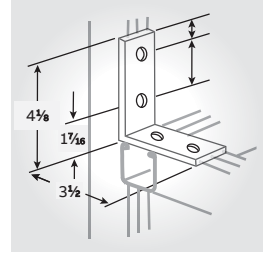

05

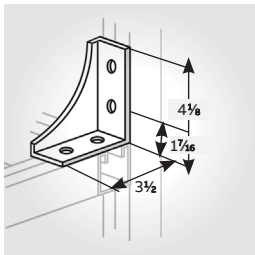

06

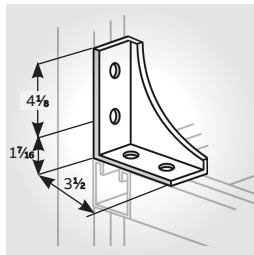

07

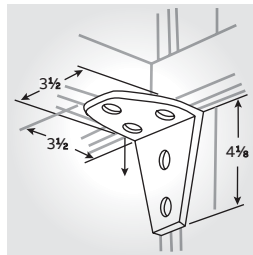

08

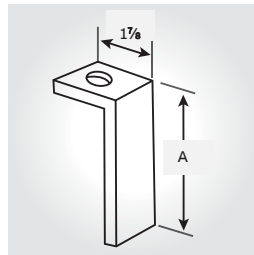

09

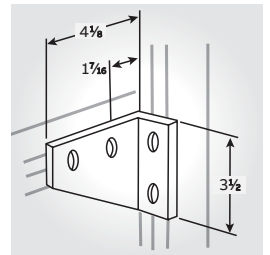

10

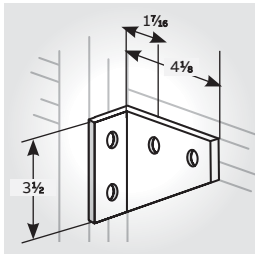

11

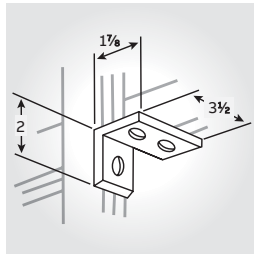

12

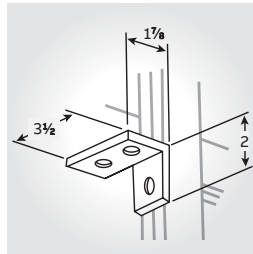

13

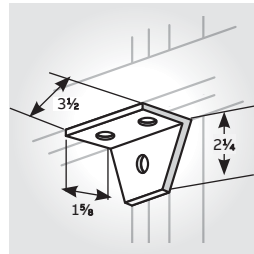

14

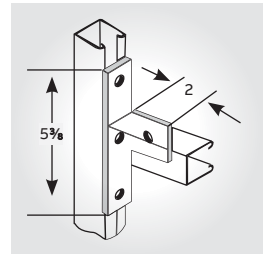

15

01 **AB201**  
AB201HDGC  
AB201EG  
AB201  
AB201SS6C  
Wt./C 35 lb

02 **AB202**  
AB202HDGC  
AB202EG  
AB202  
AB202SS6C  
Wt./C 35 lb

03 **AB203**  
AB203HDGC  
AB203EG  
AB203  
AB203SS6C  
Wt./C 58 lb

04 **AB204**  
AB204HDGC  
AB204EG  
AB204  
AB204SS6  
Wt./C 58 lb

05 **AB205**  
AB205HDGC  
AB205EG  
AB205  
AB205SS6C  
Wt./C 78 lb

06 **AB213**  
AB213HDGC  
AB213EG  
AB213  
Wt./C 125 lb

07 **AB214**  
AB214HDGC  
AB214EG  
AB214  
AB214SS6  
Wt./C 125 lb

08 **AB216**  
AB216HDGC  
AB216EG  
AB216SS6C  
Wt./C 135 lb

Cat. no.	A Wt./C	
	(in.)	lb
AB252-1*	3 7/8	61
AB252-2*	5 7/8	84
AB252-3*	7 7/8	107
AB252-4*	9 7/8	130

\*Finishes  
• HDGC  
• EG  
• GoldGalv®

10 **AB254R**  
AB254RHDGC  
AB254REG  
AB254R  
Wt./C 105 lb

11 **AB254L**  
AB254LHDGC  
AB254LEG  
AB254L  
Wt./C 105 lb

12 **AB260R**  
AB260RHDGC  
AB260REG  
AB260R  
Wt./C 58 lb

13 **AB260L**  
AB260LHDGC  
AB260LEG  
AB260L  
Wt./C 58 lb

14 **AB274**  
AB274HDGC  
AB274EG  
AB274  
Wt./C 70 lb

15 **AB275**  
AB275HDGC  
AB275EG  
AB275SS6C  
Wt./C 77 lb

### Standard dimensions

Hole spacing	1 3/16 in. from end
Hole spacing	1 7/8 in. centers
Hole size	5/16 in. diam.
Material	1 1/8 in. width
Material	1/4 in. thick

### Materials

HDG(C)	Hot-dipped galvanized
EG(C)	Electrogalvanized
(No suffix)	GoldGalv®
SS6(C)	Stainless steel 316

All dimensions shown are in in.

## Fittings and brackets

### 90° fittings

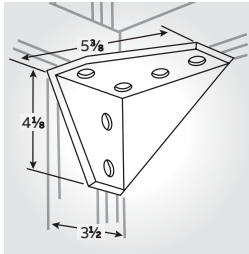

01

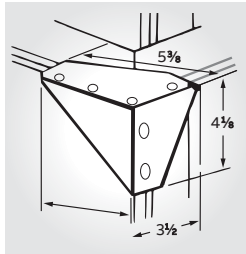

02

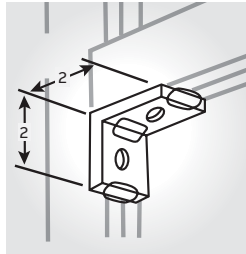

03

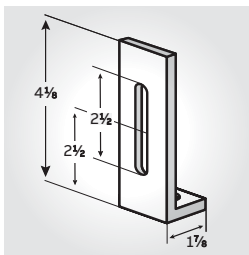

04

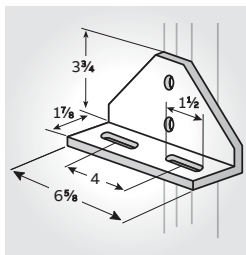

05

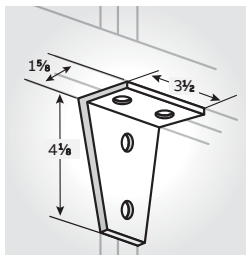

06

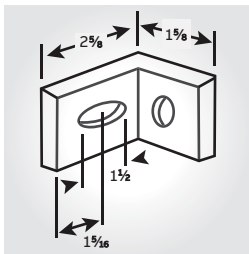

07

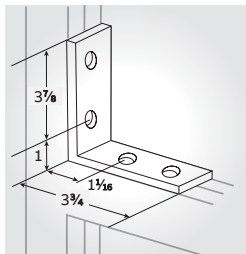

08

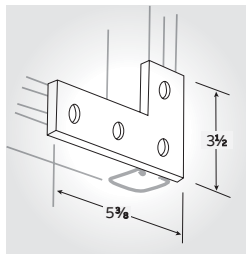

09

01 **AB284R**  
AB284RHDG  
AB284REG  
AB284R  
Wt./C 230 lb

02 **AB284L**  
AB284LHDG  
AB284LEG  
AB284L  
Wt./C 230 lb

03 **AB299**  
AB299HDG  
AB299EG  
AB299  
Wt./C 40 lb

04 **X201**  
X201HDG  
X201EG  
X201  
Wt./C 65 lb

05 **X204**  
X204HDG  
X204EG  
X204  
Wt./C 1-90 lb

06 **X289**  
X289HDG  
X289EG  
X289  
Wt./C 105 lb

07 **X299**  
X299HDG  
X299EG  
X299  
Wt./C 38 lb

08 **N205**  
N205HDG  
N205EG  
N205  
N205SS6C  
Wt./C 74 lb

09 **N219**  
N219HDG  
N219EG  
N219  
N219SS6  
Wt./C 71 lb

### SuperMag™

#### Magnetic fittings for Superstrut metal framing

Powerful, nickel-plated magnets embedded in the most popular Superstrut steel fittings, including square washers, L-brackets, T-brackets and 90° angle brackets, secure the fitting to the strut during assembly. Acting as a third hand, SuperMag fittings allow the installer to work more efficiently and safely with tools and hardware.



#### Magnetic 90° angle fitting,

#### SilverGalv™

#### AB202M EG

2-hole, 1 1/8" H x 2" L (pkg. qty. 50)



#### AB205M EG

4-hole, 4 3/8" H x 3 1/2" L (pkg. qty. 25)



#### Magnetic flat bracket,

#### SilverGalv

#### AB219M EG

L-bracket (pkg. qty. 25)



#### AB220M EG

T-bracket (pkg. qty. 25)



#### Magnetic square washer

#### SilverGalv

#### AB241M 1/4 EG

For 1/4" bolt (pkg. qty. 100)

#### AB241M 3/8 EG

For 3/8" bolt (pkg. qty. 100)

#### AB241M 1/2 EG

For 1/2" bolt (pkg. qty. 100)

All dimensions shown are in in.

Note: The magnets are only intended for use as an installer aid, not as a permanent installation method on their own. Magnetic fittings must be bolted in place following the same standard installation procedures as non-magnetic fittings for permanent installation. Standard finish is SilverGalv (EG). Best for use with traditional or spring channel nuts.

# Fittings and brackets

## Angular and "Z" shape fittings

### Angular fittings

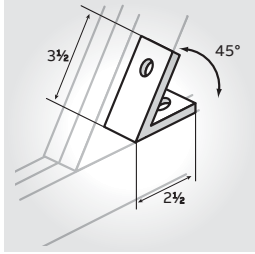

01

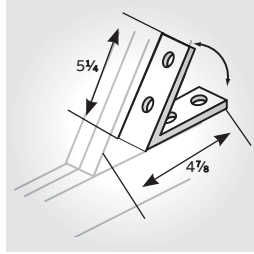

02

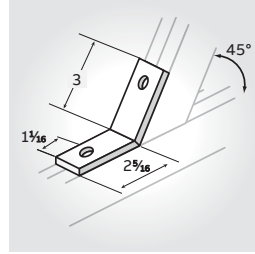

03

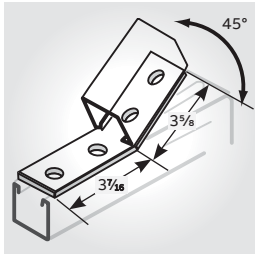

04

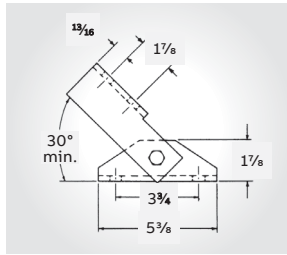

05

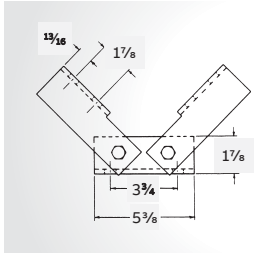

06

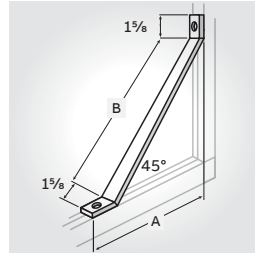
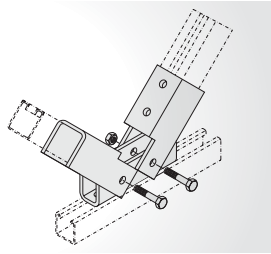

07

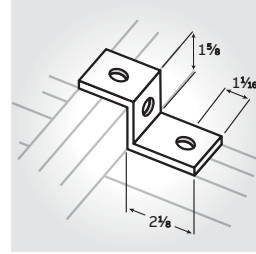

08

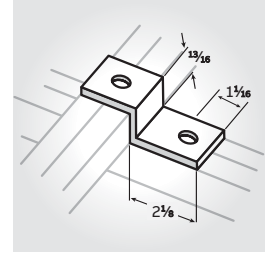

09

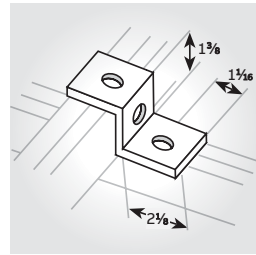

10

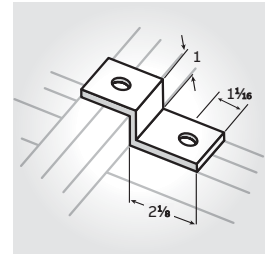

11

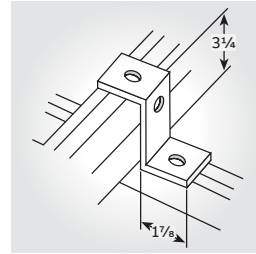

12

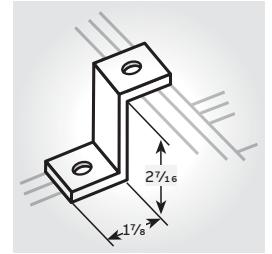

13

### Angular fittings

01 **AB225**  
AB225HDGC  
AB225EG  
AB225  
AB225SS6  
Wt./C 58 lb  
Other angles available.  
Contact your regional sales office.

02 **AB226**  
AB226HDGC  
AB226SS6  
Wt./C 119 lb  
Other angles available.  
Contact your regional sales office.

03 **AB227**  
AB227HDGC  
AB227EG  
AB227  
AB227SS6  
Wt./C 58 lb  
Other angles available.  
Contact your regional sales office.

04 **AB228**  
AB228HDGC  
AB228SS6C  
Wt./C 69 lb  
Other angles available.  
Contact your regional sales office.

05 **AB231**  
AB231EG

06 **AB232**  
AB232EG

07 **AB239**  
\*Finishes  
• HDGC  
• EG  
• GoldGalv®

### "Z" shaped fittings

08 **A209**  
A209HDGC  
A209EG  
A209  
A209SS6  
Wt./C 55 lb  
For attaching A and AR series channel.

09 **B209**  
B209HDG  
B209EG  
B209  
Wt./C 43 lb  
For attaching B and BR series channel.

10 **C209**  
C209  
Wt./C 49 lb  
For attaching C series channel.

11 **D209**  
Wt./C 45 lb  
For attaching D series channel.

12 **CZ209**  
For attaching H series and A back to back.

13 **EZ209**  
EZ209HDGC  
EZ209EG  
EZ209  
EZ209SS6  
For attaching E series channel.

Cat. no.	A (in.)	B (in.)	Wt./C lb
AB239-1*	7 13/16	8 1/2	148
AB239-2*	13 3/4	17	255
AB239-3*	19 3/4	25 1/2	363

### Standard dimensions

Hole spacing	1 3/16 in. from end
Hole spacing	1 7/8 in. centers
Hole size	5/16 in. diam.
Material	1 1/8 in. width
Material	1/4 in. thick

### Materials

HDG(C)	Hot-dipped galvanized
EG(C)	Electrogalvanized
(No suffix)	GoldGalv®
SS6(C)	Stainless steel 316

All dimensions shown are in in.

# Fittings and brackets

## “U” shape fittings

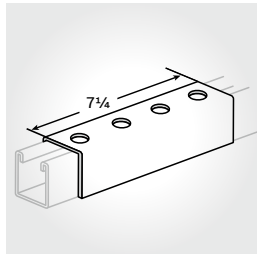

01

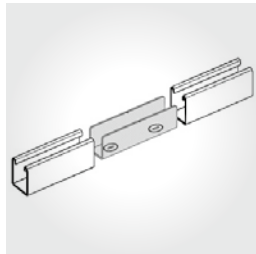

02

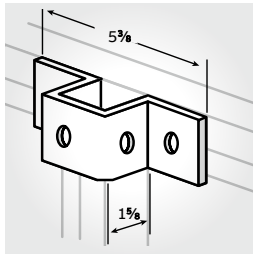

03

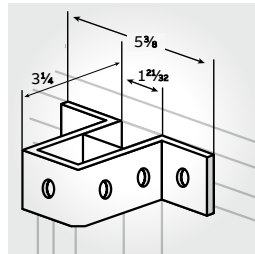

04

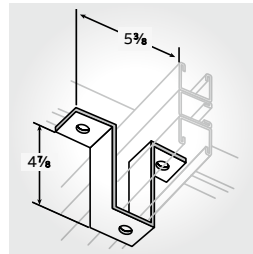

05

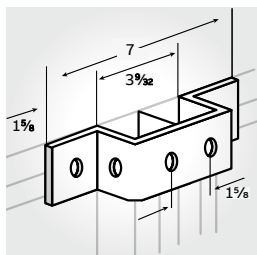

06

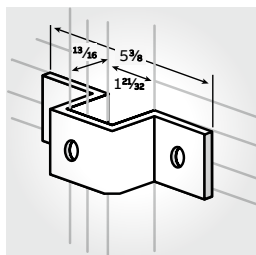

07

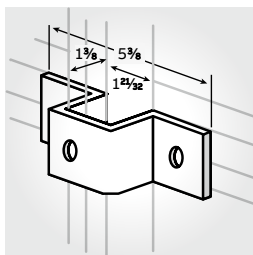

08

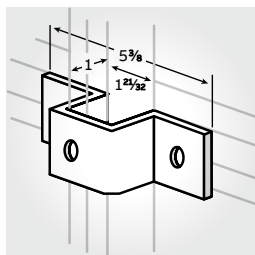

09

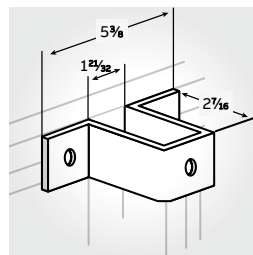

10

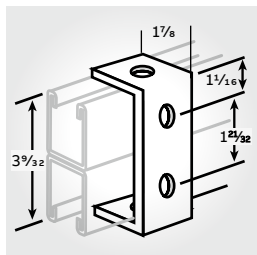

11

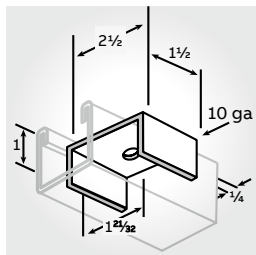

12

**01 A208**

A208HDGC  
A208EG  
A208  
A208SS6C  
Wt./C 275 lb  
Does not include stud nut or bolts.  
For A and AR series channel.

**02 Inside Strut joiner SJ-12-PG** for series A1200 joiner c/w 2 set screws finish pre-galv.

**SJ-14-PG** for series A1400 joiner c/w 2 set screws finish pre-galv.

**A213** Inside joiner For A1200 Series. Available only in GoldGalv® finish.

**03 A210**

A210HDGC  
A210EG  
A210  
A210SS6C  
Wt./C 88 lb  
For attaching A and AR series channel.

**04 A211**  
A211HDGC  
A211EG  
A211  
Wt./C 128 lb  
For attaching A and AR series double channel, and H series.

**05 AN211**  
AN211HDG  
AN211EG  
AN211  
Wt./C 181 lb

**06 A212**

A212HDG  
A212EG  
A212  
A212SS6  
Wt./C 113 lb

**07 B210**  
B210HDG  
B210EG  
B210  
B210SS6  
Wt./C 65 lb  
For attaching B and BR series.

**08 C210**  
C210HDG  
C210EG  
C210  
Wt./C 77 lb  
For attaching C series channel.

**09 D210**

D210HDG  
D210EG  
D210  
D210SS6  
Wt./C 71 lb  
For attaching D series channel.

**10 E210**  
E210HDGC  
E210EG  
E210  
Wt./C 112 lb  
For attaching E series channel.

**11 AB245**  
AB245HDG  
AB245EG  
AB245  
Wt./C 70 lb  
For attaching A and AR series double channel.

**12 AB288**

Cat. No.	Bolt size	
	(in.)	Wt./C lb
AB288-3/8*	3/8	37
AB288-1/2*	1/2	37
AB288-5/8*	5/8	37

\*Finishes  
• HDGC  
• EG  
• GoldGalv®

**Standard dimensions**

Hole spacing	1 3/16 in. from end
Hole spacing	1 7/8 in. centers
Hole size	5/16 in. diam.
Material	1 5/8 in. width
Material	1/4 in. thick

**Materials**

HDG(C)	Hot-dipped galvanized
EG(C)	Electrogalvanized
(No suffix)	GoldGalv®
SS6(C)	Stainless steel 316

All dimensions shown are in in.

## Fittings and brackets

### Wing fittings

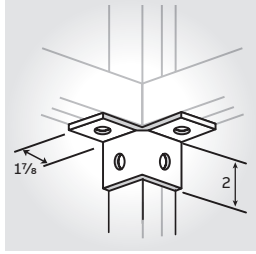

01

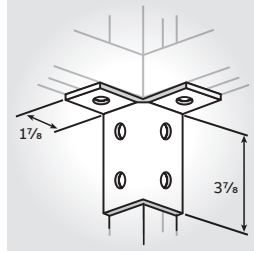

02

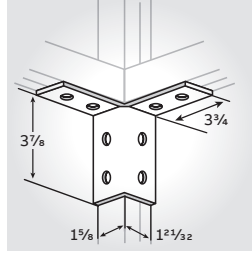

03

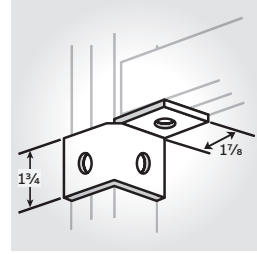

04

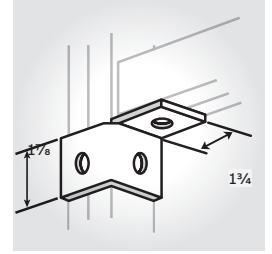

05

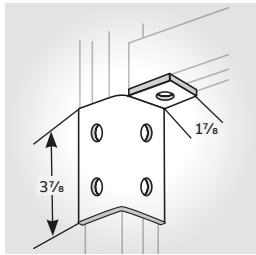

06

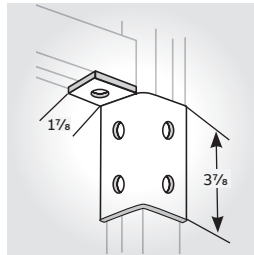

07

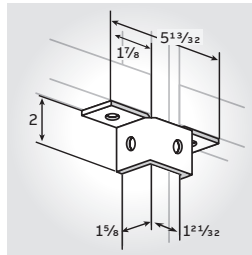

08

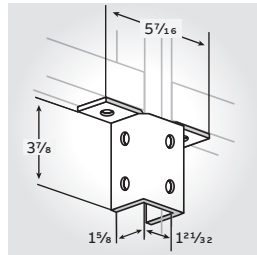

09

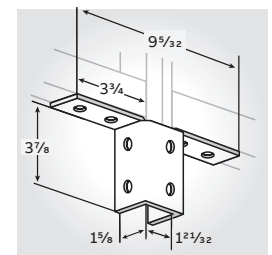

10

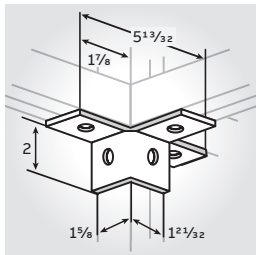

11

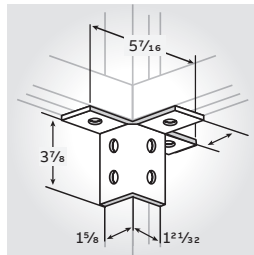

12

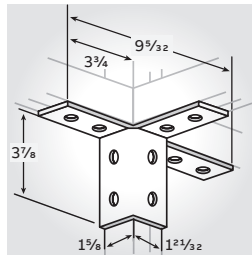

13

01 **AW204**  
AW204SS6  
AW204HDG  
AW204EG  
AW204  
Wt./C 76 lb

02 **AW214**  
AW214HDG  
AW214EG  
AW214  
Wt./C 115 lb

03 **A217**  
AW217HDG  
A217EG  
A217  
Wt./C 155 lb

04 **AW205L**  
AW205LHDG  
AW205LEG  
AW205L  
Wt./C 59 lb

05 **AW205R**  
AW205REG  
AW205R  
Wt./C 59 lb

06 **AW215L**  
AW215LHDG  
AW215LEG  
AW215L  
Wt./C 98 lb

07 **AW215R**  
AW215RHDG  
AW215REG  
AW215R  
Wt./C 98 lb

08 **AW220**  
AW220HDG  
AW220EG  
AW220  
Wt./C 90 lb

09 **AW224**  
AW224HDG  
AW224EG  
AW224  
Wt./C 147 lb

10 **AW219**  
AW219HDG  
AW219EG  
AW219  
Wt./C 187 lb

11 **AW226**  
AW226SS6  
AW226HDG  
AW226  
Wt./C 113 lb

12 **A218**  
A218HDG  
A218EG  
A218  
Wt./C 177 lb

13 **AW228**  
AW228HDG  
AW228EG  
AW228  
Wt./C 230 lb

#### Standard dimensions

Hole spacing	1 3/16 in. from end
Hole spacing	1 7/8 in. centers
Hole size	9/16 in. diam.
Material	1 5/8 in. width
Material	1/4 in. thick

#### Materials

HDG(C)	Hot-dipped galvanized
EG(C)	Electrogalvanized
(No suffix)	GoldGalv®
SS6(C)	Stainless steel 316

All dimensions shown are in inches (in.)



# Fittings and brackets

## Brackets

### S202

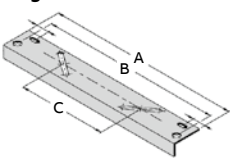
	Cat. no.	A (in.)	B (in.)	C (in.)	Wt./C lb
Diagram 	S202-6*	6	5	-	75
	S202-9*	9	8	2	100
	S202-15*	15	14	18	175
	S202-21*	21	20	14	250
	S202-27*	27	26	20	325
	S202-33*	33	32	26	400

\*Finishes  
• HDG

### S249

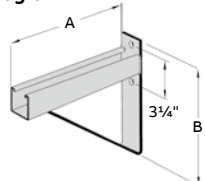
	Cat. no.	A (in.)	B (in.)	Uniform load/lb	Wt./C lb
Diagram 	S249-8*	8½	8	1,600	320
	S249-14*	14½	9	1,325	520
	S249-20*	20½	9	1,000	660

	Cat. no.	A (in.)	B (in.)	Uniform load/lb	Wt./C lb
Diagram 	S249-26*	26½	11½	850	870
	S249-32*	32½	11½	750	1,030
	S249-38*	38½	11½	600	1,230

\*Finishes  
• HDG  
• SS6C

### S251

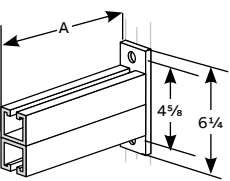
	Cat. no.	A (in.)	Uniform load/lb	Wt./C lb
Diagram 	S251-12*	12	1,650	514
	S251-14*	14½	1,650	514
	S251-18*	18	1,050	714
	S251-20*	20½	1,050	714
	S251-24*	24	800	914
	S251-26*	26½	800	914
	S251-30*	30	650	1,114
	S251-32*	32½	650	1,114
	S251-36*	36	500	1,314
	S251-38*	38½	500	1,314

\*Finishes  
• HDG  
• SS6C

### S203

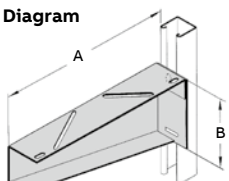
	Cat. no.	A (in.)	B (in.)	Uniform load/lb	Wt./C lb
Diagram 	S203-8*	8½	4½ <sup>16</sup>	325	180
	S203-14*	14½	5¾	325	325
	S203-20*	20½	6 <sup>11</sup> <sub>16</sub>	325	525
	S203-26*	26½	8	325	675
	S203-32*	32½	8	325	840
	S203-38*	38½	8	325	1,050

\*Finishes  
• HDG

### S250

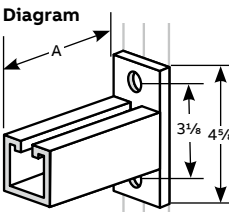
	Cat. no.	A (in.)	Uniform load/lb	Wt./C lb
Diagram 	S250-6*	6	1,500	150
	S250-8*	8½	1,500	150
	S250-12*	12	800	250
	S250-14*	14½	800	250
	S250-18*	18	550	350
	S250-20*	20½	550	350
	S250-24*	24	400	450
	S250-26*	26½	400	450

\*Finishes  
• HDG  
• SS6C

May be installed inverted with no change in load ratings.

### S256

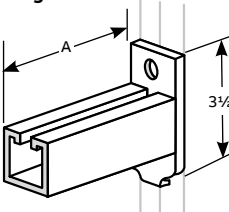
	Cat. no.	A (in.)	Uniform load/lb	Wt./C lb
Diagram 	S256-6*	6	1,000	151
	S256-8*	8½	1,000	151
	S256-12*	12	500	251
	S256-14*	14½	500	251
	S256-18*	18	300	351
	S256-20*	20½	300	351
	S256-24*	24	250	451
S256-26*	26½	250	451	

\*Finishes  
• HDG  
• SS6C

When installed in inverted position reduce load rating 40%.

#### Standard dimensions

Hole spacing	19/16 in. from end
Hole spacing	1 7/8 in. centers
Hole size	9/16 in. diam.
Material	1 1/8 in. width
Material	3/4 in. thick

#### Materials

HDG(C)	Hot-dipped galvanized
EG(C)	Electrogalvanized
(No suffix)	GoldGalv®
SS6(C)	Stainless steel 316

# Fittings and brackets

## Brackets

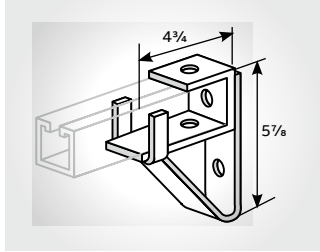

01

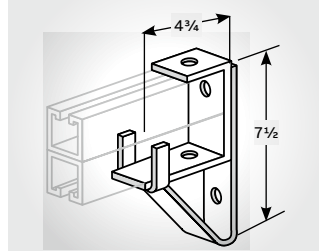

02

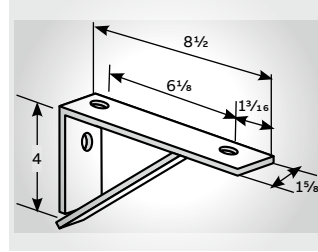

03

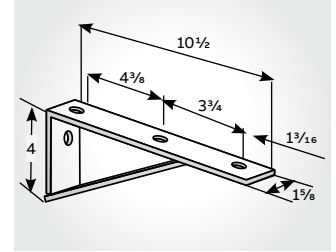

04

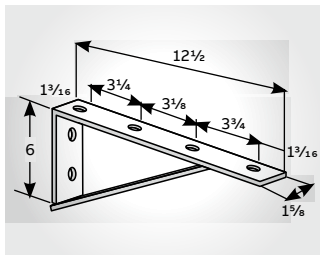

05

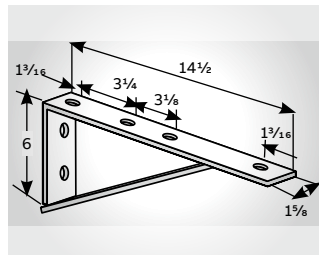

06

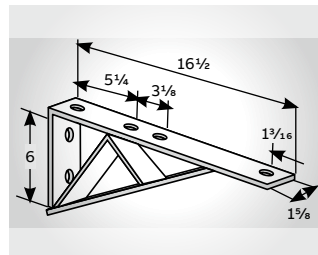

07

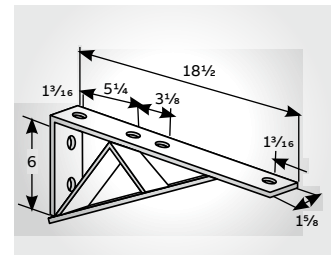

08

01 **S247**  
S247HDG  
S247  
S247SS6  
Design moment  
(channel upright  
as shown)  
When supported by  
A-1200 5,250 inch lb  
A-1400 3,650 inch lb  
Applies to fitting  
only, not to the arm.

02 **S248**  
S248HDG  
S248  
Design moment  
(channel upright  
as shown)  
When supported by  
A-1202 10,800 inch lb  
A-1402 7,550 inch lb  
Applies to fitting  
only, not to the arm.

03 **S204**  
S204HDG  
S204  
Wt./C 174 lb

Design uniform load/lb	
A-1200	750
A-1400	500

04 **S205**  
S205HDG  
S205  
Wt./C 264 lb

Design uniform load/lb	
A-1200	750
A-1400	500

05 **S217**  
S217HDG  
S217  
S217SS6  
Wt./C 264 lb

Design uniform load/lb	
A-1200	750
A-1400	650

06 **S218**  
S218HDG  
S218  
Wt./C 295 lb

Design uniform load/lb	
A-1200	750
A-1400	650

07 **S222**  
S222HDG  
S222  
Wt./C 385 lb

Design uniform load/lb	
A-1200	1,000
A-1400	750

08 **S226**  
S226HDG  
S226-TB\*\*  
Wt./C 421 lb  
\*\*GoldGalv

Design uniform load/lb	
A-1200	1,000
A-1400	750

### Standard dimensions

Hole spacing	1 3/16 in. from end
Hole spacing	1 7/8 in. centers
Hole size	5/16 in. diam.
Material	1 5/8 in. width
Material	1/4 in. thick

### Materials

HDG(C)	Hot-dipped galvanized
EG(C)	Electrogalvanized
(No suffix)	GoldGalv®
SS6(C)	Stainless steel 316

All dimensions shown are in in.

# Fittings and brackets

## Post bases

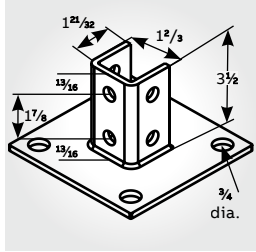

01

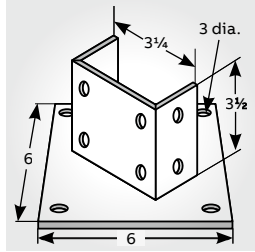

02

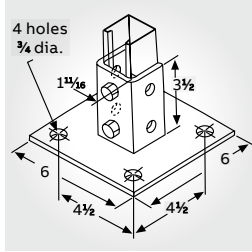

03

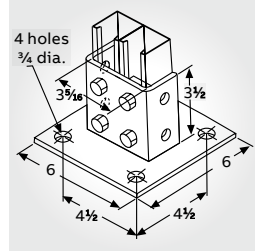

04

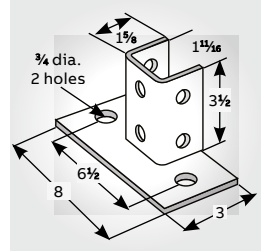

05

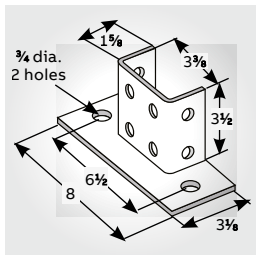

06

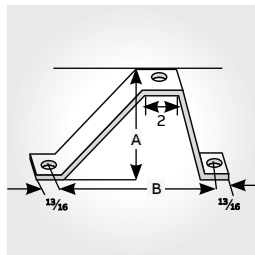

07

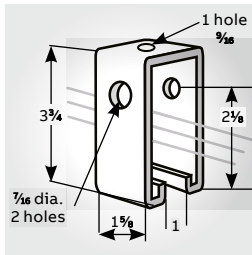

08

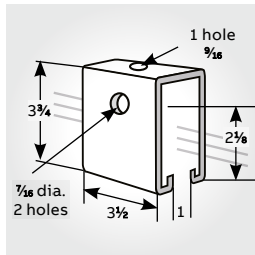

09

01 **AP232**  
AP232HDGC  
AP232EG  
AP232  
Wt./C 384 lb

02 **AP235**  
AP235HDGC  
AP235EG  
AP235-TB\*\*  
Wt./C 400 lb  
\*\*GoldGalv

03 **AP232SQ**  
AP232SQHDGC  
AP232SQEG  
AP232SQSS6  
Wt./C 384 lb

04 **AP235SQ**  
AP235SQHDGC  
AP235SQEG  
AP235SQ  
AP235SQSS6  
Wt./C 400 lb

05 **AP232FL**  
AP232FLHDG  
AP232FLEG  
AP232FL  
Wt./C 272 lb

06 **AP235FL**  
AP235FLEG  
AP235FL  
Wt./C 360 lb

07 **AN270**  
\*Finishes  
• HDG  
• EG

08 **TS272 Track support**  
TS272HDG  
Requires 3/8 in. x 2 1/2 in. bolt and nut (not included)  
Design load: 1,000 lb  
Wt./C 104 lb

09 **TS273 Track support**  
TS27  
For use over channel splice  
Requires 3/8 in. x 2 1/2 in. bolt and nut (not included)  
Design load: 2,000 lb  
Wt./C 228 lb

All dimensions shown are in in.

Cat. no.	A	B	Wt./C lb
AN270-1*	2 3/8	6	113
AN270-2*	4 3/8	8	151
AN270-3*	6 3/8	10	199
AN270-4*	8 3/8	12	246
AN270-5*	10 3/8	14	293

## Fittings and brackets

### Special application fittings and brackets

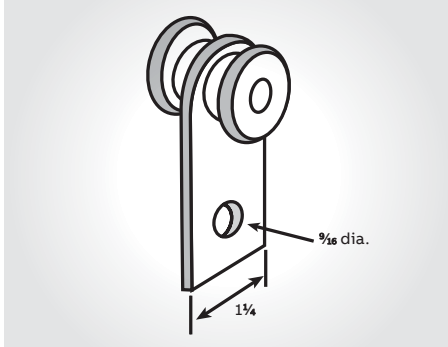

01

**01 TR292**  
 Can be used for series A, E and H channels only. Standard finish is electrogalvanized. Frictionless needle bearings. Design load: 500 lb Safety factor of 5. Wt./C 59 lb

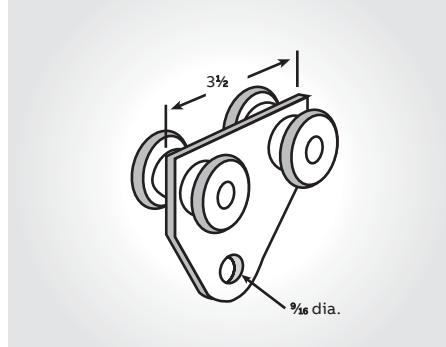

02

**02 TR294**  
 Can be used for series A, E and H channels only. Standard finish is electrogalvanized. Frictionless needle bearings. Design load: 1,000 lb Safety factor of 5. Wt./C 106 lb

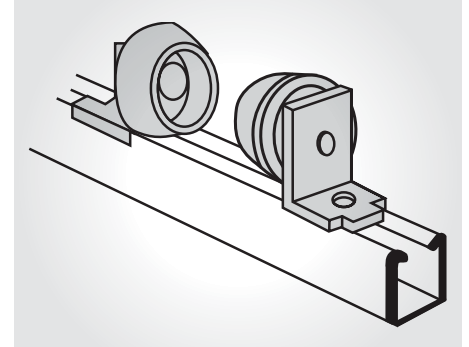

03

**03 C728 Pipe roller (pair)**  
 Cast aluminum rollers, steel brackets. Designed for standard saddles. Order separately for each pair of rollers: two 1/2 in. x 3/16 in. hex head cap screws and two 1/2 in. channel nuts. Space to suit O.D. of pipe and wrapping. Design load: 2,350 lb Wt./C : 300 lb

## Adjustable universal support

Support building services and access equipment on flat roofs and flat surfaces

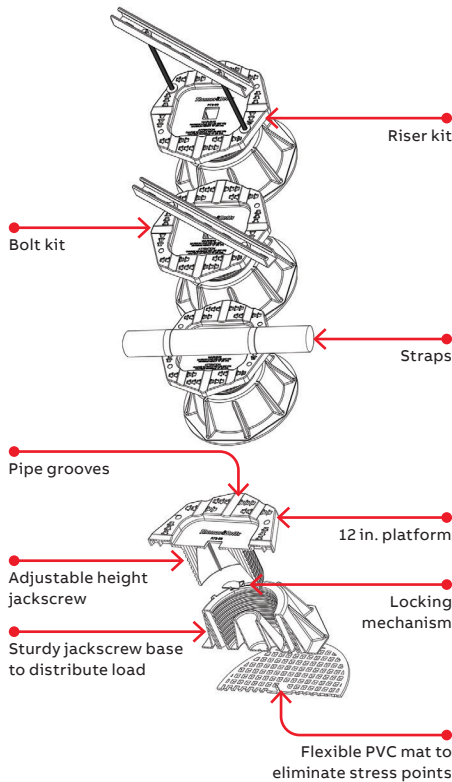

The ABB adjustable universal support (AUS) provides an easy method for supporting pipes, conduit and equipment on flat roofs, below raised floors and even on level ground applications. The AUS reduces installation time compared to other support solutions such as wooden blocks, cement blocks, straps and clips. These labor-intensive solutions also increase the danger of roof membrane penetration.

The AUS system allows for tool-free adjustment of the pedestal height from 6 to 9 inches with a twist of the wrist. This ensures that the supported objects

or pipes are uniformly supported and no high stress supports are carrying a disproportionate load in a single location.

Cat. no.	Description	Qty.
AUS14-96	Adjustable universal support (base only)	1
AUS-RISER-KIT	Riser kit	
A1200HS100PG	14 in. strut	1
H104-1/2X10EGC	12 in. threaded rod	2
E145-1/2EGC	Nut	8
E147-1/2EGC	Washer	8
E148-1/2EGC	Lock washer	4
AUS-STRUT-KIT	Bolt kit	
A1200HS100PG	14 in. strut	1
E142-1/2X200EGC	Bolt	2
E145-1/2EGC	Nut	2
E147-1/2EGC	Washer	4
E148-1/2EGC	Lock washer	2
AUS125PCSS6	4 1/2 in. stainless steel 316 strap (to restrain 1 1/4 in. pipe)	2
AUS150PCSS6	5 in. strap (to restrain 1 1/2 in. pipe)	2
AUS200PCSS6	6 in. strap (to restrain 2 in. pipe)	2

---

## Beam clamps

### Design loads

Where design loads are indicated, they provide for a safety factor of 3 in conformance with the American Standard Code for Pressure Piping. For more information, see page A66 for engineering data and specifications.

### Finishes and special materials

Hot-dipped galvanized (HDGC) is standard for all Superstrut beam clamps. The material is zinc coated after fabrication providing total product

protection on all surfaces. The fabricated beam clamps are suspended and then dipped into tanks of hot zinc for a prolonged period, creating a coherent bond.

Selected beam clamps can also be available in GoldGalv® (no suffix) or stainless steel type 316 (SS6C). Contact your regional sales office for availability and minimum quantities.

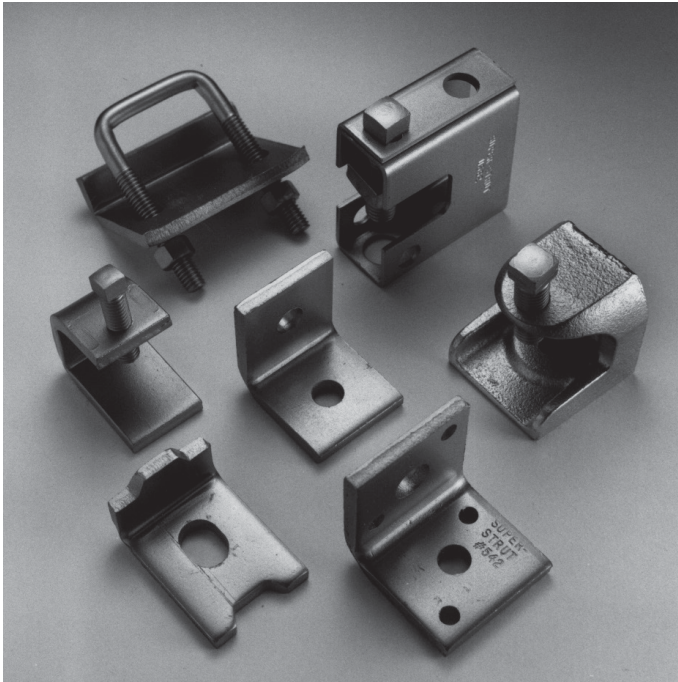

# Beam clamps

Beam clamps for mounting channel

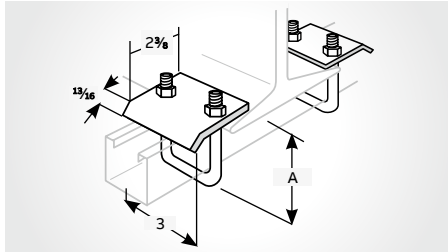

01

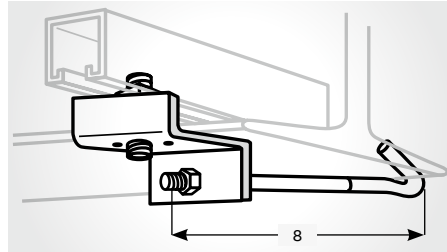

02

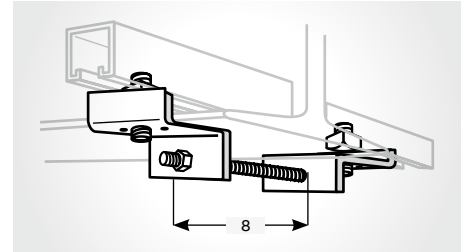

03

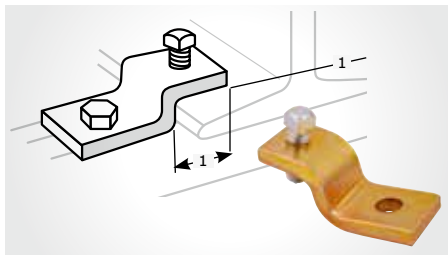

04

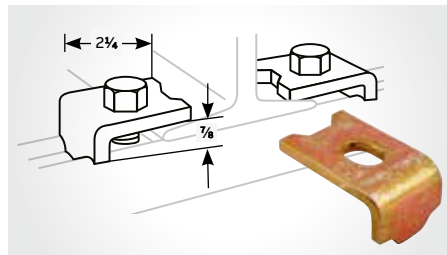

05

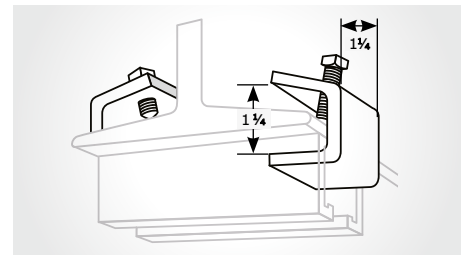

06

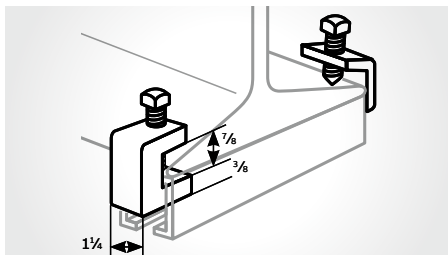

07

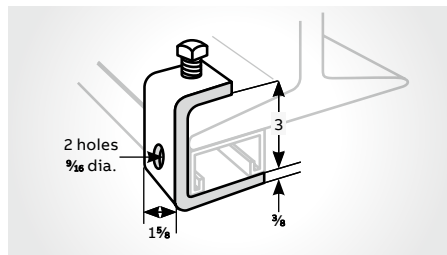

08

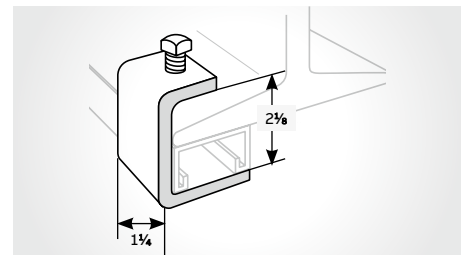

09

**01 U501, U502**

Furnished complete.  
Design load  
U501-TB\* : 2,150 lb  
U502 : 3,000 lb

- \*Finishes
- HDG
  - EG
  - GoldGalv®
  - SS6C

Cat. no.	For channel		Size	Wt./C lb
			(in.)	
U501*	A1200	A1400	3 3/16	90
	B1200	B1400	3 3/16	90
	C1200	B1402	3 3/16	90
U502*	A1202	A1402	4 13/16	100
	C1202	H1200	4 13/16	100

**02 U504**

U504HDG  
U504EG  
U504  
U504SS6  
Can be used with all channels.  
Wt./C 140 lb

**03 U505**

U505HDG  
U505EG  
U505  
Can be used with all channels.  
Wt./C 270 lb

**04 U510**

U510HDGC  
U510EG  
U510  
U510SS6

Design load/lb	Channel
1,000	A-1200
800	A-1400

1/2 in. x 1 1/2 in. set screw included.  
Order separately one 1/2 in. x 1 1/2 in. hex head cap screw and 1/2 in. channel nut.  
Wt./C 75 lb

**05 512U**

512UHDG  
512UEG  
512U

Design load/lb	Channel
1,000	A-1200
800	A-1400

Order separately one 1/2 in. x 1 1/2 in. hex head cap screw and 1/2 in. channel nut.  
Wt./C 26 lb

**06 U514**

U514HDGC  
U514EG  
U514  
U514SS6  
3/8 in. x 1 1/2 in. set screw included.  
Design load 750 lb/pair  
Wt./C 40 lb

**07 U514-A**

U514-AHDGC  
U514-AEG  
U514-A  
U514-ASS6  
1/2 in. x 1 1/2 in. set screw included.  
Design load 1,650 lb/pair  
Wt./C 59 lb

**08 U515**

U515HDGC  
U515EG  
U515  
U515SS6  
For all A series channel.  
1/2 in. x 1 1/2 in. set screw included.  
Design load 800 lb  
Wt./C 95 lb

**09 U515B**

U515BHDG  
U515BEG  
U515B  
U515BSS6  
For all B series channel.  
1/2 in. x 1 1/2 in. set screw included.  
Design load 800 lb  
Wt./C 91 lb

**Materials**

HDG(C)	Hot-dipped galvanized
EG(C)	Electrogalvanized
(No suffix)	GoldGalv®
SS6(C)	Stainless steel 316

All dimensions shown are in in.

## Beam clamps

Beam clamps for mounting channel

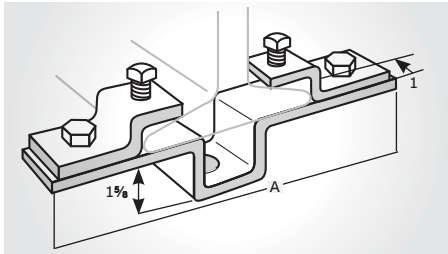

01

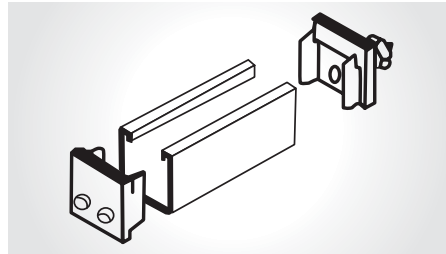

02

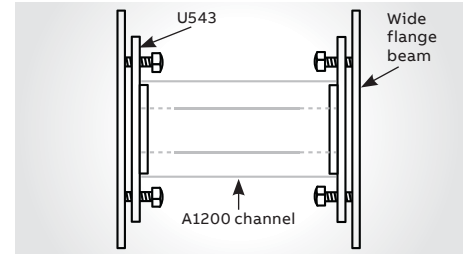

03

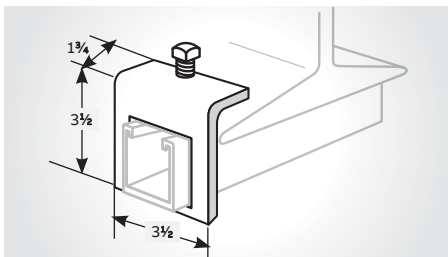

04

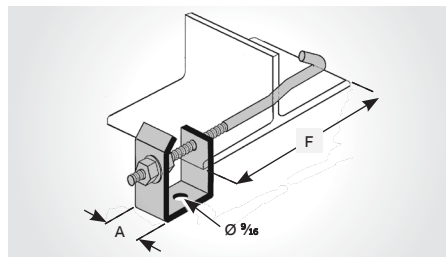

05

01 U520, U521, U522

\*Finishes  
• GoldGalv®

Cat. no.	Flange Width	A	Wt./C lb	Design load lb/ea
U520*	2 3/8–4 1/2	8 3/4	328	2,000
U521*	3 3/4–5 3/4	10	343	1,300
U522*	5 5/8–7 5/8	11 5/8	353	900

Nuts, cap screws and set screws included.

02 U544 Single adjusting screw end cap set

U544EG  
Should be ordered as one set.  
Wt./C 39 lb

03 U543 Adjusting screw end caps

U543HDG  
U543EG  
U543  
Should be ordered in multiples of two (2).  
Wt./C 44 lb

04 A597

\*Finishes  
• HDGC  
• SS6C

Cat. no.	Channel series		Wt./C lb	Design load lb/ea
	A	F		
A597*	A		108	800

05 U570-1, U570-2

\*Finishes  
• HDGC

Cat. no.	A (in.)	F (in.)	Wt./C	Design
			lb	load lb/ea
U570-1*	1 1/2	4 to 9	240	800
U570-2*	1 1/2	7 to 17	300	800

Materials

HDG(C)	Hot-dipped galvanized
EG(C)	Electrogalvanized
(No suffix)	GoldGalv®
SS6(C)	Stainless steel 316

All dimensions shown are in in.

# Beam clamps

## Beam clamps for hanging rod

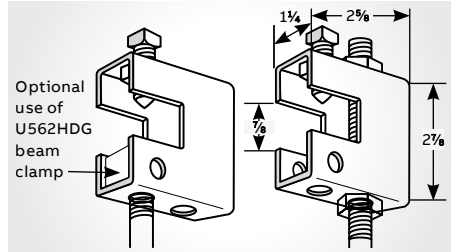

01

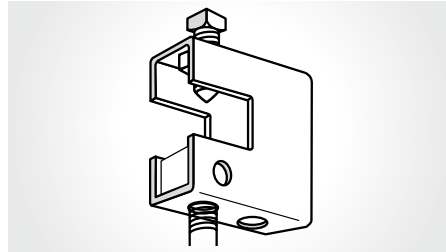

02

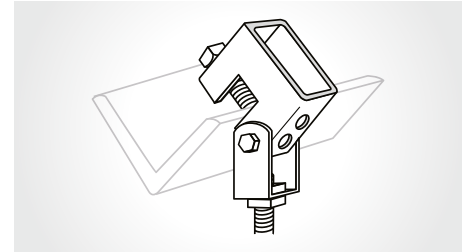

03

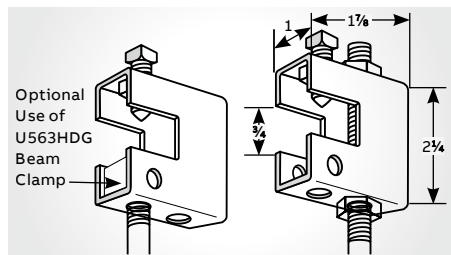

04

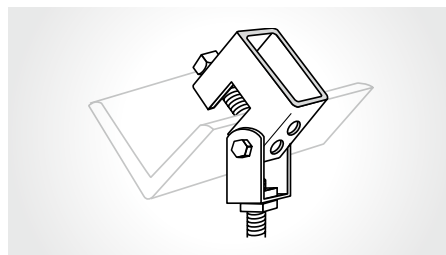

05

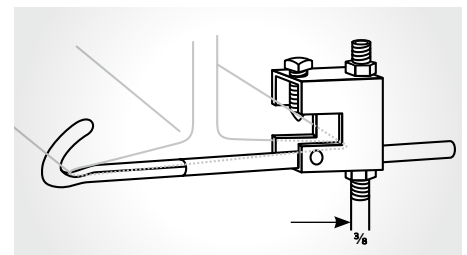

06

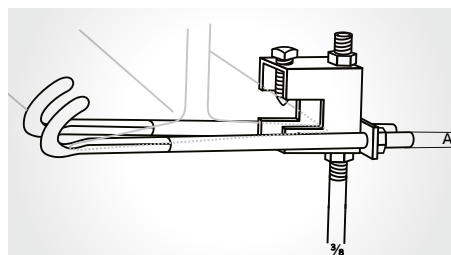

07

**01 U562 Beam clamp**  
 U562HDG  
 U562EG  
 U562  
 E146 square nut  
 order separately.  
 1/2 in. set screw  
 included.

Rod size (in.)	Wt./C lb	Design load lb/ea
1/2	80	800

For 20° swivel application use ES-145-1/2 nut. 1/2 in. set screw included.

Rod size (in.)	Wt./C lb	Design load lb/ea
1/2	80	500

**02 UM562 Beam clamp**  
 UM562HDGC  
 UM562SS6  
 E146 square nut  
 order separately.  
 1/2 in. set screw  
 included.

Rod size (in.)	Wt./C lb	Design load lb/ea
1/2	100	1,200

For 20° swivel application use ES-145-1/2 nut.

**03 US562 Beam clamp with Swing Hanger**  
 US562HDG  
 US562EG  
 US562  
 US562  
 E146 square nut  
 order separately.  
 1/2 in. set screw  
 included.

Rod size (in.)	Wt./C lb	Design load lb/ea
1/2	113	800

**04 U563 Beam clamp**  
 U563HDG  
 U563EG  
 U563  
 U563SS6  
 Square nut order  
 separately.  
 3/8 in. set screw  
 included.

Rod size (in.)	Wt./C lb	Design load lb/ea
3/8	33	400

3/8 in. set screw included.

Rod size (in.)	Wt./C lb	Design load lb/ea
3/8	33	240

**05 US563 Beam clamp with swing hanger**  
 US563HDG  
 US563  
 US563  
 3/8 in. set screw  
 included.

Rod size (in.)	Wt./C lb	Design load lb/ea
3/8	50	400

Materials	
HDG(C)	Hot-dipped galvanized
EG(C)	Electrogalvanized
(No suffix)	GoldGalv®
SS6(C)	Stainless steel 316

**06 U569 Beam clamp**  
 U569HDG  
 U569  
 Maximum flange  
 width 5 in.

Cat. no.	A size (in.)	Wt./C lb	Design load lb/ea
U569	3/8	150	400

**07 A570 Beam clamp with safety rod**  
 Flange width 4 in.  
 min.–8 in. max.  
 For use with 5/8 in.  
 rod see U-569.

Cat. no.	A size (in.)	Wt./C lb	Design load lb/ea
A570HDG	1/2	220	500

All dimensions shown are in in.



# Beam clamps

Beam clamps for hanging rod

## U560 Heavy-duty beam clamp

	Cat. no.	A (in.)	B (in.)	C (in.)	Wt./C lb	Design load, lb
Diagram	U560-1/4*	¼	⅜	¾ x 1½	67	1,050
	U560-3/8*	⅜	⅜	¾ x 1½	67	1,050
	U560-1/2*	½	¼	½ x 1½	130	2,650
	U560-5/8*	⅝	¼	½ x 1½	130	2,650

\*Finishes  
 • GoldGalv®  
 • EG

## U564 Heavy-duty beam clamp

	Cat. no.	A (in.)	B (in.)	C (in.)	Wt./C lb	Design load, lb
Diagram	U564-3/8*	⅜	⅜	¾ x 2¾	109	1,300
	U564-1/2*	½	¼	½ x 2¾	201	3,150
	U564-5/8*	⅝	¼	½ x 2¾	201	3,150

\*Finishes  
 • GoldGalv®  
 • EG

## U568 Beam clamp safety strap For U563 beam clamp.

Cat. no.	Beam flange width (in.)	A (in.)	Wt./C lb
U568-1EG	6	8	18
U568-2EG	9	11	28

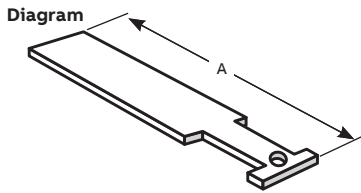

16 gauge material

## U568 Beam clamp safety strap For U562 and UM562 beam clamp.

Cat. no.	Beam flange width (in.)	A (in.)	Wt./C lb
U568-3EG	6	9	25
U568-4EG	9	12	33
U568-5EG	12	15	42

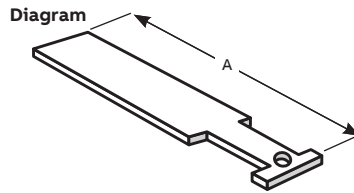

16 gauge material

## U568 Beam clamp safety strap For U560 and U564 beam clamp.

Cat. no.	Beam flange width (in.)	A (in.)	Wt./C lb
U568-6EG	6	9	33
U568-7EG	9	12	42
U568-8EG	12	15	24

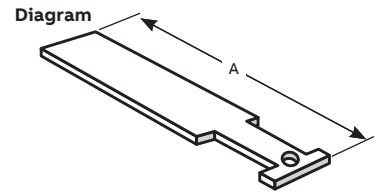

16 gauge material

## C775L/M775L Clamp with lock nut

Diagrams	Cat. no.	Pipe size (in.)	Dimensions			Wt./C lb	Design load, lb
			A (in.)	B (in.)	C (in.)		
	C775L-3/8EG	⅜	⅜	⅜	¾	38	400
	C775L-1/2EG	½	⅜	⅜	¾	39	500
	C775L-5/8EG	⅝	½	½	¾	60	550
	C775L-3/4EG	¾	⅝	⅝	¾	69	600
	C775L-7/8EG	⅞	¾	¾	1	184	900
	M775L-3/8EG	⅜	⅜	¾	1¾	27	400
	M775L-1/2EG	½	½	¾	1¾	35	400
	M775L-5/8EG	⅝	⅝	¾	2	52	440
	M775L-3/4EG	¾	¾	¾	2	63	500

Standard finish – electrogalvanized (EG)  
 Malleable iron (M775L)  
 Carbon steel (C775L)

## Beam clamps

### Beam clamps for hanging rod

500SC, 502, 503SC, 507, 508, 509, 510, 511 Beam clamp

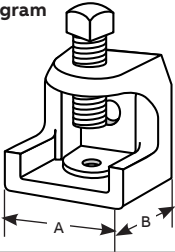
Diagram	Cat. no.	Tapped holes	Base dim.		Jaw opening (in.)	Wt./C lb	Design load/lb
			A (in.)	B (in.)			
	500SC	¼-20	1	1¼	15/16	18	450
	502	¾-16	2	2	1	92	1,300
	503SC	½-13	25/8	2½	1	164	1,300
	507	½-13	2½	2¾	1¾	165	1,700
	508	½-13	2½	2¾	2½	184	1,700
	509	10-24	1	1¼	15/16	22	375
	510	¼-20	27/32	1⅛	5/8	15	400
	511	10-24	27/32	1⅛	5/8	15	400

Standard finish – Electrogalvanized (no suffix)

### 6H series in combination with 500 series beam clamp conduit and pipe hanger

Features

- Accommodates ½ in. through 4 in. EMT or rigid conduit
- Can be used for either vertical or horizontal installation
- 6H-TB Series is threaded so there are fewer parts to handle or drop
- Installs easily with a screwdriver

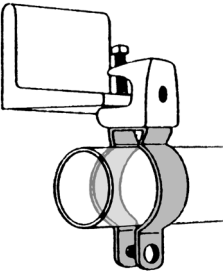
Diagram	Without bolt		With bolt		EMT (in.)	Rigid conduit or pipe (in.)	Qty. per box
	Cat. no.	Fig. no.	Cat. no.	Fig. no.			
	6H0	1	6H0-B	2	½	¾-½	100
	6H0-T	3	6H0-TB	4	½	¾-½	100
	6H1	1	6H1-B	2	¾	¾	100
	6H1-T	3	6H1-TB	4	¾	¾	100
	6H2	1	6H2-B	2	1	1	100
			6H2-TB	4	1	1	100
	6H2 1/2	1	6H2 1/2B	2	1¼	-	100
			6H2 1/2-TB	4	1¼	-	100
	6H3-SC	1	6H3-B	2	1½	1¼	100
			6H3-TB	4	1½	1¼	100
	6H4	1	6H4-B	2	-	1½	100
			6H4-TB	4	-	1½	100
	6H5	1	6H5-B	2	2	2	100
			6H5-TB	4	2	2	100
	6H6	1	6H6-B	2	2½	2½	100
	6H7	1	6H7-B	2	3	3	100
6H8	1	6H8-B	2	3½	3½	100	
6H9	1	6H9-B	2	4	4	100	

Diagrams

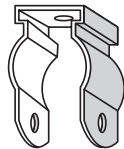

Fig. 1: 6H series without bolt

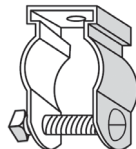

Fig. 2: 6H-B series with bolt and hex nut



Fig. 3: 6H-T threaded series threaded without bolt

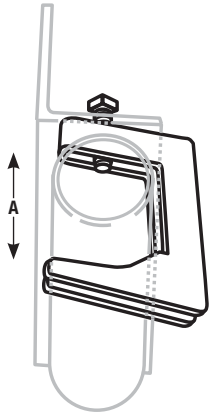

Fig. 4: 6H-TB threaded series threaded with bolt

Standard finish – electrogalvanized (no suffix). Use SS suffix for stainless steel. Load rating: 500 lb with a safety factor of 3. (For weight per 100 see page A44.)

## Beam clamps

Beam clamps for mounting pipe and conduit



### U571, U572 Conduit clamp

For attaching 1/2 in. thru 1 1/2 in. conduit to beam, channel, angle or column. Secures conduit to the support parallel or at right angles to it.

- 5/16 in. set screw
- 12 gauge material
- Standard finish – GoldGalv®
- Wt./C 38 lb

### Pipe supports

Three types of pipe clamps are available to provide right angle, vertical and parallel attachment to a beam. Types RC, EC and PC are malleable iron clamps with an edge that grips the structural member for maximum holding power when tightened.

Type RCS clamps are all steel, providing two bearing surfaces for strong attachment for mounting pipe or conduit at right angles to the beam.

All parts are electrogalvanized (no suffix) including the threads. The clamps are designed for clamping to a wide variety of beam thicknesses and tapers. Can be installed using only a wrench.

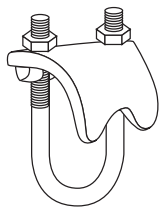

Type RC and RCS

- Malleable iron
- For mounting pipe or conduit at right angles to the beam
- Use SS316 suffix for 316 stainless steel
- Use HDG suffix for hot-dipped galvanized

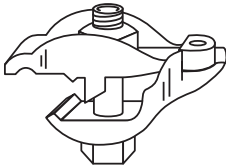

Type EC

- Malleable iron
- For mounting pipe or conduit vertically across the beam
- Use HDG suffix for hot-dipped galvanized
- CSA certified

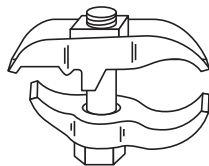

Type PC

- Malleable iron
- For mounting pipe or conduit parallel to the beam
- Use HDG suffix for hot-dipped galvanized

Cat. no.	Conduit size (in.)	Max. flange thickness (in.)	Dim. A (in.)	Wt./C lb
U571	1/2	1	1 3/4	36
	3/4	3/4	1 3/4	36
	1	1/2	1 3/4	36
U572	3/4	1 1/2	2 1/2	59
	1	1 1/4	2 1/2	59
	1 1/4	1	2 1/2	59
	1 1/2	5/8	2 1/2	59

Cat. no. and size	O.D. of conduit or pipe (in.)	Nom. conduit or pipe size (in.)	Std. ctn.	Wt./C lb
RCS-3/8	0.675	3/8	50	31
RCS-1/2	0.840	1/2	50	34
RCS-3/4	1.050	3/4	50	39
RCS-1	1.315	1	50	42
RCS-1-1/4	1.660	1 1/4	50	43
RCS-1-1/2	1.900	1 1/2	50	60
RCS-2	2.375	2	50	72
RC-1/2	0.840	1/2	50	36
RC-3/4	1.050	3/4	50	43
RC-1	1.315	1	50	49
RC-1-1/4	1.660	1 1/4	50	51
RC-1-1/2	1.900	1 1/2	50	54
RC-2-SC	2.375	2	50	76
RC-2-1/2	2.875	2 1/2	25	107
RC-3	3.500	3	25	116
RC-3-1/2	4.000	3 1/2	25	134
RC-4-SC	4.500	4	20	158
EC-1/2	0.840	1/2	50	69
EC-3/4	1.050	3/4	50	78
EC-1	1.315	1	25	83
EC-1-1/4	1.660	1 1/4	25	108
EC-1-1/2	1.900	1 1/2	25	112
EC-2	2.375	2	25	140
EC-2-1/2	2.875	2 1/2	10	183
EC-3	3.500	3	10	203
PC-3/8	0.675	3/8	50	32
PC-1/2	0.840	1/2	50	53
PC-3/4	1.050	3/4	50	53
PC-1	1.315	1	50	61
PC-1-1/4	1.660	1 1/4	25	79
PC-1-1/2	1.900	1 1/2	25	56
PC-2	2.375	2	25	116
PC-2-1/2	2.875	2 1/2	25	148
PC-3	3.500	3	10	175
PC-3-1/2	4.000	3 1/2	10	199
PC-4	4.500	4	10	224

# Beam clamps

## Beam fittings

### C781 Square washer

Std. pack 50

Cat. no.	Rod size (in.)	Hole size (in.)	Overall dimensions	Wt./C lb
C781-3/8*	3/8	7/16	3 x 3 x 3/16	27
C781-1/2*	1/2	9/16	3 x 3 x 3/16	27
C781-5/8*	5/8	11/16	3 x 3 x 1/4	47
C781-3/4*	3/4	13/16	3 x 3 x 1/4	42
C781-7/8*	7/8	15/16	4 x 4 x 3/8	85
C781-1*	1	1 1/8	4 x 4 x 3/8	160

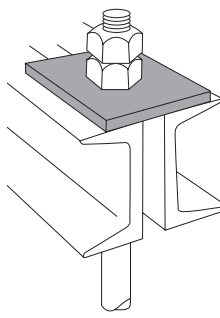

- \*Finishes
- B
  - EDG
  - EG
  - SS6

Used for beam applications.  
For channel applications, use AB241.

### 540 Side beam hanger clip

Cat. no.	A (in.)	B (in.)	C (in.)	D (in.)	Wt./C lb
540-3/8*	7/16	1 1/8	1/4	7/8	38
540-1/2*	9/16	1 1/8	1/4	1 1/8	36
540-5/8*	1 1/16	2 1/2	3/8	2	84
540-3/4*	1 3/16	2 1/2	3/8	2	113

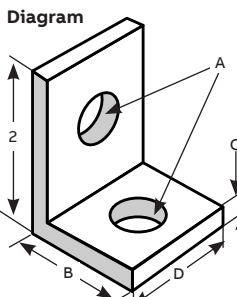

- \*Finishes
- B
  - EG
  - GoldGalv®

### S541 Swing connector

Cat. no.	Rod size (in.)	Wt./C lb
S541-3/8	3/8	31

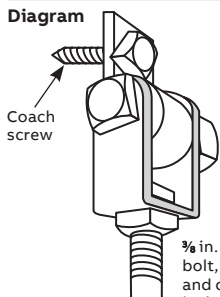

Coach screw

3/8 in. x 1 3/4 in. bolt, nut and clevis included.

Standard finish – GoldGalv®  
For use with wood beam.

### M742R Ceiling flange

Cat. no.	Rod size (in.)	Wt./C lb
M742R-3/8*	3/8	16
M742R-1/2*	1/2	16

Diagram

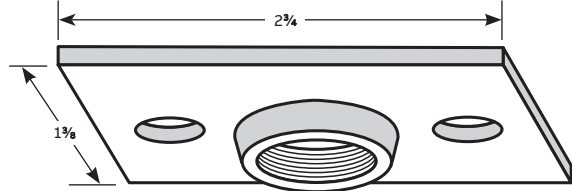

- \*Finishes
- B
  - EG

### 542 Side beam hanger clip

Cat. no.	Figure	Rod size (in.)	Design load/lb	Wt./C lb
542	1	3/8	610	35
	2	1/2	1,000	38

Diagrams

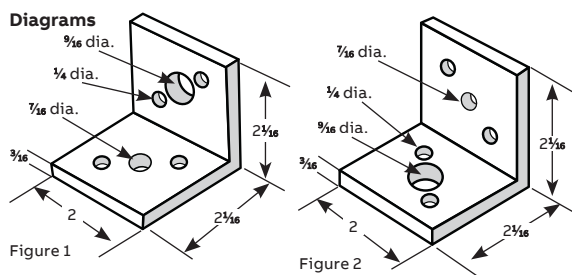

Figure 1

Figure 2

Standard finish – GoldGalv®  
For 3/8 in. and 1/2 in. rods.

### Materials

HDG(C)	Hot-dipped galvanized
EG(C)	Electrogalvanized
(No suffix)	GoldGalv®
SS6(C)	Stainless steel 316

All dimensions shown are in in.

## Beam clamps

### Beam fittings

#### U577 Clevis and swing connector

	Cat. no.	Rod size (in.)	Wt./C lb
	U577-1/2	1/2	69

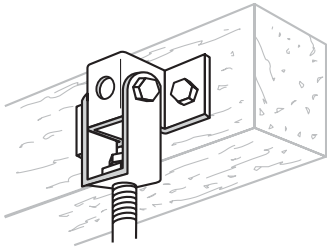

Standard finish – GoldGalv®  
For use with wood beam.

#### U576 Hanger clevis

	Cat. no.	Hole A (in.)	Material thickness B (in.)	Wt./C lb
Diagram	U576-3/8	7/16	3/16	27
	U576-1/2	9/16	3/16	27

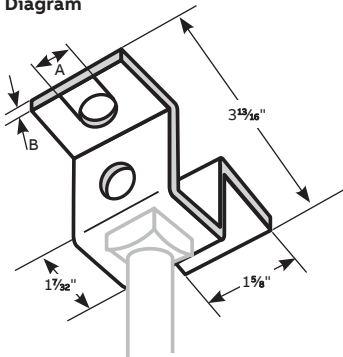

Standard finish – GoldGalv®  
For rods up to 1/2 in.  
Mounting holes 7/16 in. diameter.  
For use with wood beam.

#### U579 Ceiling flange

	Cat. no.	A (in.)	Wt./C lb
Diagram	U579-3/8	3 1/2	30
	U579-1/2	4 1/4	50

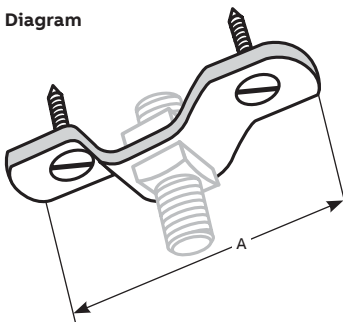

Standard finish – GoldGalv®  
Malleable iron  
Nuts and wood screws not included. Mounting holes 13/32 in.

## Pipe straps, pipe and conduit clamps and hangers

### Design loads

Where design loads are indicated, they provide for a safety factor of 3 in conformance with the American Standard Code for Pressure Piping.

### Hanger design

Pipe hangers are of advanced design to be user friendly.

### Finishes and special materials

The standard finish is electrogalvanized (EGC) or GoldGalv®. Some products are offered in aluminum and stainless steel where noted.

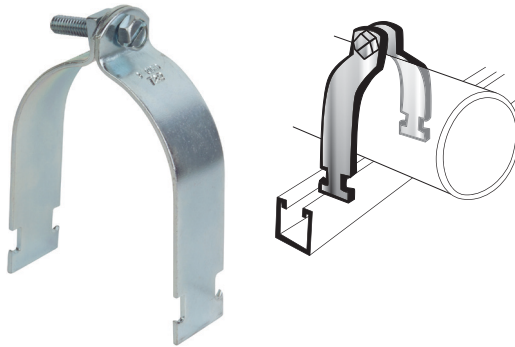

### 701 O.D. Pipe and conduit clamp

Machine screw and nut included.

### Standard finishes and materials

- PG Pregalvanized (i.e. 701-045PG)
- AL Aluminum (i.e. 701-045AL) with zinc-plated hardware
- SS6 Stainless steel type 316 (i.e. 701-045SS6)

Cat. no.	O.D. of pipe		Rigid	EMT	Std.
	(in.)	(mm)	conduit (in.)	conduit (in.)	
701-045PG	0.36-0.45	9-11.5	-	-	9 10
701-055PG	0.46-0.55	11.5-14	-	-	10 10
701-065PG	0.56-0.65	14-17	-	-	11 10
701-075PG	0.66-0.75	17-19.5	-	½	13 10
701-088PG	0.76-0.88	19.5-22.5	½	-	15 10
701-100PG	0.89-1.00	22.5-25.4	-	¾	16 10
701-113PG	1.01-1.13	25.5-29	¾	-	17 10
701-126PG	1.14-1.26	29-32	-	1	18 10
701-140PG	1.27-1.40	32-36	1	-	18 10
701-153PG	1.41-1.53	36-39	-	1¼	19 10
701-167PG	1.54-1.67	39-42.5	1¼	-	20 10
701-180PG	1.68-1.80	42.5-46	-	1½	23 10
701-193PG	1.81-1.93	46-49	1½	-	26 10
701-204PG	1.93-2.04	49-52	-	-	30 10
701-225PG	2.10-2.25	53-57.5	-	2	32 10
701-237PG	2.26-2.37	57.5-60	2	-	34 10
701-245PG	2.33-2.45	59.95-62.5	-	-	36 10
701-257PG	2.46-2.57	62.5-65.5	-	-	38 10
701-287PG	2.75-2.87	70-73	2½	2½	40 10
701-294PG	2.88-2.94	73-75	-	-	42 10
701-306PG	2.95-3.06	75-78	-	-	42.5 10
701-319PG	3.07-3.19	78-81	-	-	43 10
701-350PG	3.36-3.50	85.5-89	3	3	45 10
701-356PG	3.51-3.56	89-90	-	-	46 10
701-379PG	3.70-3.79	94-96.5	-	-	48 10
701-400PG	3.80-4.00	96.5-101.5	3½	3½	49 10
701-450PG	4.25-4.50	108-114	4	4	70 10
701-556PG	5.25-5.56	121-141	5	5	75 5
701-665PG	6.25-6.65	146-170	6	6	80 5
701-876PG	8.50-8.75	197-222	8	8	85 5

# Pipe straps, pipe and conduit clamps and hangers

## Conduit and cable clamps

### 703 Universal clamp



Cat. no.	EMT/rigid (in.)	Conduit O.D.	Material thickness (gauge)	Wt./C lb	Std. ctn.
703-1/2EG	1/2	0.706–0.840	16	13	100
703-3/4EG	3/4	0.932–1.050	14	14	100
703-1EG	1	1.163–1.315	14	15	100
703-1-1/4EG	1 1/4	1.508–1.660	14	18	50
703-1-1/2EG	1 1/2	1.738–1.900	14	28	50
703-2EG	2	2.195–2.375	14	29	50

Diagram

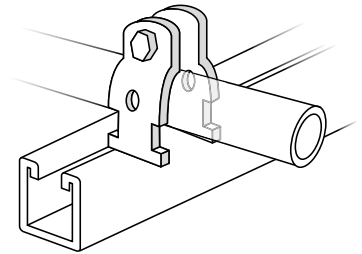

Standard finishes – GoldGalv® (i.e.) 703-1/2  
 Electrogalvanized (EG suffix) (i.e.) 703-1-1/2EG  
 One size fits both rigid and electric metal tubing (EMT).  
 Individually assembled with screw and nut.

### Quik Clamp II™



Cat. no.	Dimension Trade size in. (mm)	Dimension A EMT in. (mm)	Dimension A rigid conduit in. (mm)	Quantity per box	Wt./C lb	Design load 1 static load limit lb (kg)	Design load 2 lb (kg)	Design load 3 lb (kg)
TBQC050	1/2 (12.7)	1/2 (12.7)	1/2 (12.7)	100	10	200 (90)	50 (23)	50 (23)
TBQC075	3/4 (19.05)	3/4 (19.05)	3/4 (19.05)	100	12	200 (90)	50 (23)	50 (23)
TBQC100	1 (44.5)	1 (44.5)	1 (44.5)	100	13	200 (90)	50 (23)	50 (23)
TBQC125	1 1/4 (31.75)	1 1/4 (31.75)	1 1/4 (31.75)	50	15	200 (90)	50 (23)	50 (23)
TBQC150	1 1/2 (38.1)	1 1/2 (38.1)	1 1/2 (38.1)	50	16	200 (90)	50 (23)	50 (23)
TBQC200	2 (50.8)	2 (50.8)	2 (50.8)	50	19	200 (90)	50 (23)	50 (23)
TBQC250	2 1/2 (63.5)	2 1/2 (63.5)	2 1/2 (63.5)	25	29	350 (158)	50 (23)	50 (23)
TBQC300	3 (76.2)	3 (76.2)	3 (76.2)	25	34	350 (158)	50 (23)	50 (23)
TBQC350	3 1/2 (88.9)	3 1/2 (88.9)	3 1/2 (88.9)	25	38	350 (158)	50 (23)	50 (23)
TBQC400	4 (101.6)	4 (101.6)	4 (101.6)	25	42	350 (158)	50 (23)	50 (23)

Diagrams

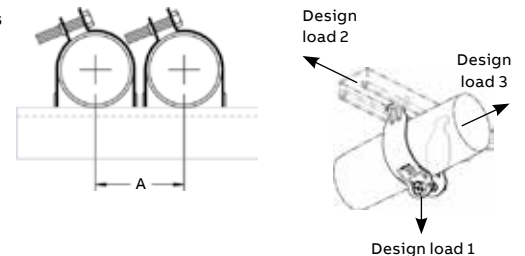

Design load 1 has a safety factor of 4.  
 Design loads 2 and 3 have a safety factor of 1.  
 Standard material electrogalvanized steel.

# Pipe straps, pipe and conduit clamps and hangers

## Conduit and cable clamps



Cobra® clamp



Cat. no.	Rigid EMT cond. trade size (in.)		Cable O.D. range (in.)	Static load limit (lb) safety factor = 4	Qty. per box	Wt./C lb	Torque value (in.-lb)	Design load 1		
	size (in.)	size (in.)						Static load limit (lb) (kg)	Design load 2 (lb) (kg)	Design load 3 (lb) (kg)
CPC025	¼	¼	0.312–0.600	200	100	8	35	200 (91)	50 (23)	50 (23)
CPC050	½	½	0.650–0.890	200	100	10	35	200 (91)	50 (23)	50 (23)
CPC075	¾	¾	0.860–1.110	200	100	12	35	200 (91)	50 (23)	50 (23)
CPC100	1	1	1.100–1.400	200	100	14	35	200 (91)	50 (23)	50 (23)
CPC125	1¼	1¼	1.400–1.725	200	50	16	35	200 (91)	50 (23)	50 (23)
CPC150	1½	1½	1.690–1.980	200	50	18	35	200 (91)	50 (23)	50 (23)
CPC200	2	2	1.980–2.576	200	50	24	35	200 (91)	50 (23)	50 (23)
CPC250	2½	2½	2.576–3.060	350*	25	36	35	350 (159)	50 (23)	50 (23)
CPC300	3	3	3.060–3.626	350*	25	42	35	350 (159)	50 (23)	50 (23)
CPC350	3½	3½	3.626–4.126	350*	25	46	35	350 (159)	50 (23)	50 (23)
CPC400	4	4	4.126–4.626	350*	25	50	35	350 (159)	50 (23)	50 (23)

Diagram

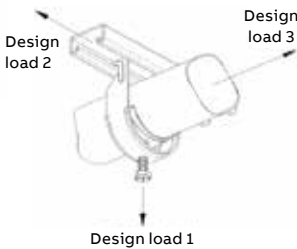

\* Aluminum product has a static load of 250 lb  
 Standard material is commercial-grade, bright electrogalvanized steel.  
 Aluminum: Add the suffix AL to the catalogue number (i.e. CPC050AL)  
 Stainless steel: Add the suffix SS6 to catalogue number (i.e.: CPC050SS6). Stainless steel bolt head is hexagonal and slotted only.



Loc-King Cobra™ clamp

- Superior design load capabilities for heavy-duty applications
- Pre-set torque prevents over-tightening
- Anti-vibration nut
- Steel construction with GoldGalv® finish



Cat. no.	Rigid EMT cond. trade size (in.)		Cable O.D. range (in.)	Static load limit (lb) safety factor = 4	Qty. per box	Wt./C lb	Torque value (in.-lb)	Design load 1		
	size (in.)	size (in.)						Static load limit (lb) (kg)	Design load 2 (lb) (kg)	Design load 3 (lb) (kg)
LKCPC050	½	½	0.650–0.890	100	15	10	35	300 (136)	50 (23)	50 (23)
LKCPC075	¾	¾	0.860–1.110	100	16	12	35	300 (136)	50 (23)	50 (23)
LKCPC100	1	1	1.100–1.400	50	19	14	35	300 (136)	50 (23)	50 (23)
LKCPC125	1¼	1¼	1.400–1.725	50	23	16	35	300 (136)	50 (23)	50 (23)
LKCPC150	1½	1½	1.690–1.980	50	27	18	35	300 (136)	50 (23)	50 (23)
LKCPC200	2	2	1.980–2.576	50	38	24	35	300 (136)	50 (23)	50 (23)
LKCPC250	2½	2½	2.576–3.060	25	44	36	35	450 (204)	50 (23)	50 (23)
LKCPC300	3	3	3.060–3.626	25	53	42	35	450 (204)	50 (23)	50 (23)
LKCPC350	3½	3½	3.626–4.126	25	58	46	35	450 (204)	50 (23)	50 (23)
LKCPC400	4	4	4.126–4.626	25	66	50	35	450 (204)	50 (23)	50 (23)

Diagram

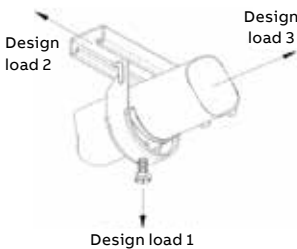



# Pipe straps, pipe and conduit clamps and hangers

## Conduit and cable clamps

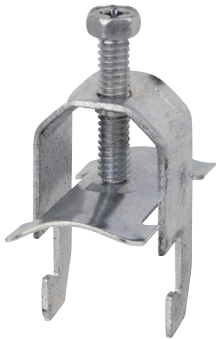

**CH118 Heavy-duty cable clamp**

Diagram	Cat. no.	O.D. of cable or pipe		Rigid cond. (in.)	EMT cond. (in.)	WT./C. lb
		(in.)	(mm)			
	CH118-055EG	0.40-0.55	10-14	-	-	8
	CH118-081EG	0.50-0.81	13-21	1/2	1/2	9
	CH118-110EG	0.70-1.10	18-28	3/4	3/4	17
	CH118-125EG	0.85-1.25	22-27	3/4	1	18
	CH118-135EG	1.00-1.35	26-36	1	1	19
	CH118-175EG	1.33-1.75	34-44	1 1/4	1 1/4	21
	CH118-205EG	1.65-2.05	42-52	1 1/2	1 1/2	24
	CH118-250EG	2.12-2.50	54-64	2	2	48
	CH118-300EG	2.60-3.00	66-76	2 1/2	2 1/2	54
	CH118-325EG	2.75-3.25	70-82	-	-	65
	CH118-375EG	3.25-3.75	82-94	3	3	105
	CH118-425EG	3.75-4.25	94-110	3 1/2	3 1/2	113
	CH118-475EG	4.25-4.75	110-120	4	4	124

Available in double or triple configurations.

**Example: Double – CH128-047EG**

**Triple – CH138-047EG**

Standard finishes – Electrogalvanized (EG)

Stainless steel type 316 clamp comes with type 304 stainless steel hardware.

**CB118 Counterbed**  
**EB118 Extended bed**  
**DB118 Double bed**

Diagrams	Cat. no.	Wt./C. lb	
	<b>Counterbed</b>		
	CB118-055PG	1	
	CB118-090PG	2	
	CB118-110PG	3 1/2	
	CB118-140PG	4	
	CB118-175PG	4 1/2	
	CB118-200PG	5	
	CB118-250PG	11	
	CB118-300PG	13	
	<b>Extended bed</b>		
	EB118-047PG	4	
	EB118-055PG	4 1/2	
	EB118-090PG	6	
EB118-110PG	13 1/2		
EB118-140PG	16		
EB118-175PG	17		
EB118-200PG	20		
EB118-250PG	30		
EB118-300PG	38		
<b>Double bed</b>			
DB118-047PG	2		
DB118-055PG	2		
DB118-070PG	3		

Standard finish – Pregalvanized (PG)

## Pipe straps, pipe and conduit clamps and hangers

### Conduit and cable clamps



#### A716 Snap-Guard® cushioned clamp tube series

#### P716 Snap-Guard® cushioned clamp pipe series

- Assembly consisting of GoldGalv® finish steel clamp with bolt/locknut and cushion
- Secure pipes, tubes and hoses for fluid conductors
- Installation is easy and requires no more time than a simple pipe clamp installation
- Cushion absorbs the shocks and associated vibrations from fluid surges in tubes, pipes and hoses
- It can handle temperatures from 149 °C to -40 °C (300 °F to -40 °F)
- Cushioned clamp assemblies are available individually bagged

Diagram	Assembly cat. no.	Tubing		Assembly cat. no.	Standard pipe		
		Tube O.D. (in.)	Wt./C lb		Nominal pipe size (in.)	Std. ctn.	Wt./C lb
	A716-1/4	¼	10	P716-1/4	¼	25	10
	A716-3/8	⅜	14	P716-3/8	⅜	25	14
	A716-1/2	½	16	P716-1/2	½	25	16
	A716-5/8	⅝	16	P716-3/4	¾	25	18
	A716-3/4	¾	18	P716-1	1	25	22
	A716-7/8	⅞	18	P716-1-1/4	1¼	25	27
	A716-1	1	22	P716-1-1/2	1½	10	36
	A716-1-1/8	1⅛	24	P716-2	2	10	43
	A716-1-1/4	1¼	27	P716-2-1/2	2½	10	49
	A716-1-3/8	1⅜	27	P716-3	3	10	60
	A716-1-1/2	1½	36	P716-3-1/2	3½	10	62
	A716-1-5/8	1⅝	37	P716-4	4	10	94
	A716-1-3/4	1¾	37	-	-	10	-
	A716-1-7/8	1⅞	43	-	-	10	-
	A716-2	2	43	-	-	10	-
	A716-2-1/8	2⅛	44	-	-	10	-
	A716-2-3/8	2⅜	49	-	-	10	-
	A716-2-5/8	2⅝	53	-	-	10	-
	A716-3-1/8	3⅛	62	-	-	10	-
	A716-4-1/8	4⅛	94	-	-	10	-

## Pipe straps, pipe and conduit clamps and hangers

### Conduit and cable clamps

#### U716 Two-hole cushioned clamp

- Guides, protects and uniformly spaces line runs. Low cost, time saving method of attaching tubing and hose to equipment.
- Cushion is built to withstand the effects of most oils, chemical and industrial cleaning compounds, in temperatures from -45 °C to 121 °C (-50 °F to 275 °F). Interlock edge ensures cushion remains in place.
- Attached with two standard fasteners to any flat surface, this clamp eliminates the use of special channels, providing a savings in both space requirements and cost
- Cushioned clamps reduce vibration, shock and noise in fluid systems and eliminates electrolysis

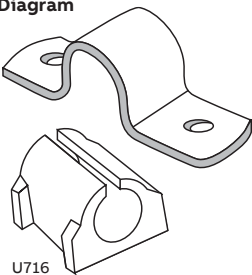
	Assembly cat. no.	Copper and steel tubing O.D. (in.)	Copper water pipe (nom.) (in.)	Normal pipe size (in.)	Std. ctn.	Wt./C lb
<b>Diagram</b>  U716	U716-1/4	3/4	–	–	25	3
	U716-3/8	3/8	3/4	–	25	4
	U716-1/2	1/2	3/8	3/4	25	6
	U716-5/8	5/8	1/2	3/8	25	6
	U716-3/4	3/4	5/8	–	25	7
	U716-7/8	7/8	3/4	1/2	25	7
	U716-1	1	–	–	25	8
	U716-1-1/8	1-1/8	1	–	25	8
	U716-1-1/4	1-1/4	–	–	10	17
	U716-1-3/8	1-3/8	1 1/4	–	10	20
	U716-1-1/2	1-1/2	–	–	10	22
	U716-1-5/8	1-5/8	1 1/2	–	10	23
	U716-2	2	–	–	10	41
	U716-2-1/8	2-1/8	–	–	10	41
	U716-2-3/8	2-3/8	–	–	10	44

Standard finish – GoldGalv®

## Pipe straps, pipe and conduit clamps and hangers

### Conduit and cable clamps

#### 6H series conduit and pipe hanger

##### Features

- Accommodates ½ in. through 4 in. EMT or rigid conduit
- Can be used for either vertical or horizontal installation
- 6HTB Series have a built-in nut so there are fewer parts to handle or drop
- Installs easily with a screwdriver

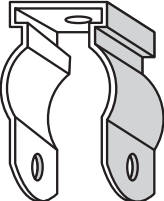
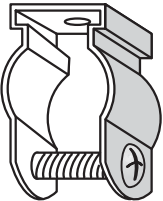
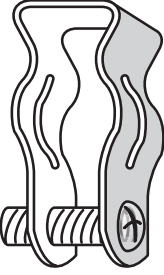
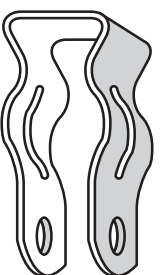
Diagrams	Cat. no.	Conduit size		Wt./C. lb
		Rigid (in.)	EMT (in.)	
 <p>6H Series</p>	6H0	¾–½	½	5
	6H0-B	¾–½	½	7
 <p>6H-B Series with bolt and hex nut</p>	6H0-T	¾–½	½	5
	6H0-TB	¾–½	½	6
 <p>6H-TB Threaded series</p>	6H1	¾	¾	6
	6H1-B	¾	¾	7
	6H1-T	¾	¾	6
	6H1-TB	¾	¾	7
 <p>6H-T Threaded series</p>	6H2	1	1	7
	6H2-B	1	1	9
	6H2-1/2	–	1¼	8
	6H2-1/2-B	–	1¼	10
	6H3-SC	1¼	1½	8
	6H3-B	1¼	1½	10
	6H3-TB	1¼	1½	10
	6H4	1½	–	17
	6H4-B	1½	–	19
	6H4-TB	1½	–	19
	6H5	2	2	24
	6H5-B	2	2	26
	6H5-TB	2	2	26
	6H6	2½	2½	28
	6H6-B	2½	2½	30
	6H7	3	3	36
	6H7-B	3	3	38
	6H8	3½	3½	39
	6H8-B	3½	3½	41
	6H9	4	4	44
	6H9-B	4	4	47

Standard finish – Electrogalvanized (no suffix)

## Pipe straps, pipe and conduit clamps and hangers

### Conduit and cable clamps



When fastening wire bundles, cables or hoses to framing channels, you can cut costs considerably by using this mounting base. It is made of smooth, weather-resistant nylon and designed to protect cable insulation and hoses from the wear or damage that can occur with metal clamps. The mounting base may be used for both indoor or outdoor applications. It installs in the framing channel with a simple push and twist. It requires

no screws, nuts or tools. The mounting base fits all 1½ in. and 1¾ in. channels regardless of channel depth. Ty-Rap® and Ty-Fast® cable ties can be ordered separately.

- Installs with a push and twist
- Designed for indoor or outdoor use
- Smooth design protects cable insulation
- Takes range of cable diameters

Cat. no.	Channel size (in.)	Maximum tie width accom. (in.)	Unit qty.	Std. pkg.
TC5363X	1½ and 1¾	0.301	50	250

#### Installation

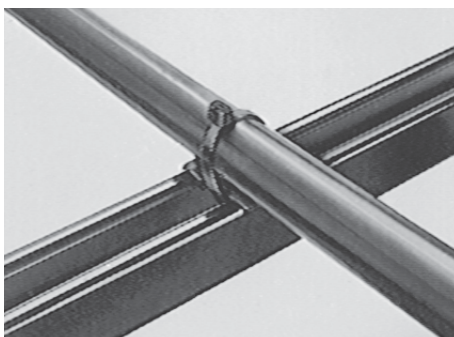
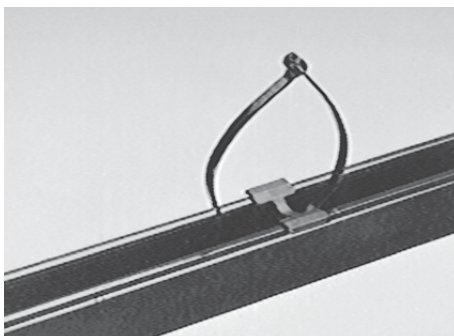
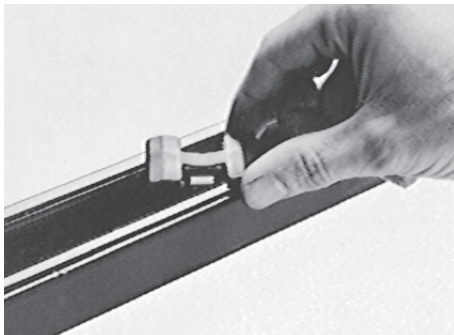

# Pipe straps, pipe and conduit clamps and hangers

## Conduit and cable clamps

**WS716 Maple hardwood saddle**  
Std. pack 10

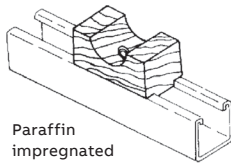

Paraffin impregnated maple.

Cat. no.	Dimensions						
	Hardwood paraffin imp.	Depth (in.)	Depth (mm)	Width (in.)	Width (mm)	Height (in.)	Height (mm)
WS716-3/4	3/4	19.0	3	76.2	1 3/4	44.4	
WS716-1	1	25.4	3	76.2	1 3/4	44.4	
WS716-1-1/4	1 1/4	31.7	3 1/2	88.9	2	50.8	
WS716-1-1/2	1 1/2	38.1	3 1/2	88.9	2	50.8	
WS716-1-3/4	1 3/4	44.4	4	101.6	2 1/4	57.1	
WS716-2	2	50.8	4	101.6	2 1/4	57.1	
WS716-2-1/4	2 1/4	57.1	4 1/2	114.3	2 1/2	63.5	
WS716-2-1/2	2 1/2	63.5	4 1/2	114.3	2 1/2	63.5	
WS716-2-3/4	2 3/4	69.8	5	127	2 3/4	69.8	
WS716-3	3	76.2	5	127	2 3/4	69.8	
WS716-3-1/4	3 1/4	82.5	5 1/2	139.7	2 3/4	76.2	
WS716-3-1/2	3 1/2	88.9	5 1/2	139.7	3	76.	
WS716-3-3/4	3 3/4	95.2	6	152.4	3 1/4	82.5	
WS716-4	4	101	6	152.4	3 1/4	82.5	
WS716-4-1/2	4 1/2	114.3	6 1/2	165.1	3 1/2	88.9	
WS716-5	5	127	7	177.8	3 3/4	95.2	
WS716-5-1/2	5 1/2	139.7	7 1/2	190.5	4	101.6	
WS716-6	6	152.4	8	203.2	4 1/4	107.9	
WS716-6-1/2	6 1/2	165.1	8 1/2	215.9	4 1/2	114.3	
WS716-7	7	177.8	9	228.6	4 3/4	120.6	

Diagram

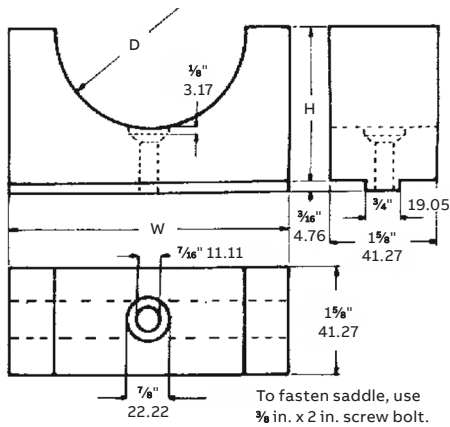

## Pipe straps, pipe and conduit clamps and hangers

### Conduit and cable clamps

—  
**AB880 3 in. Porcelain saddle**  
**AB881 4 in. Porcelain saddle**



	Cat. no.	A (in.)	Max. cable diam. (in.)	Wt./C lb
Diagram	AB880	3	3	73
	AB881	4	4½	104

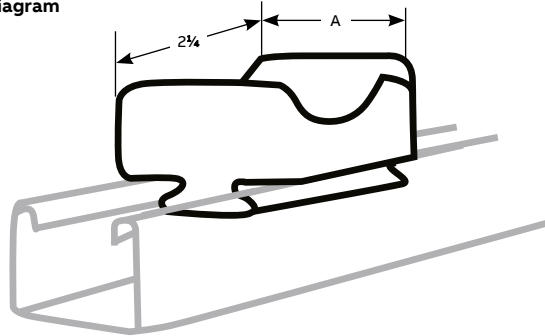

# Pipe straps, pipe and conduit clamps and hangers

## Conduit and cable clamps



For use with 701 O.D. tubing and pipe clamp. To determine 701 clamp size add 1/4 in. to O.D. tube size to allow for the cushioned strip material.

### S716-TB Cushioned strip for isolation and vibration applications

1/4 in. markings for fast measuring and cutting. Measurement chart is printed on back of carton. 20 feet included in each carton. Prevent metal-to-metal contact with the cushioned strip material. It aids in sound insulation, shock

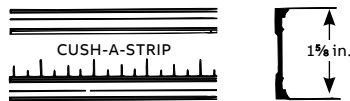

absorption and protects against corrosion, distortion and abrasion. Cushioned strip material is designed for optimal use between -1 °C and 149 °C (30 °F and 300 °F). Cushioned strip material combined with the Superstrut 701 pipe strap can handle clamping assignments from 1/4 in. to 6 in.

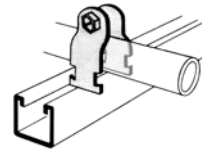

Order 701 clamp separately.



### C708U Short strap for channel or wall mounting

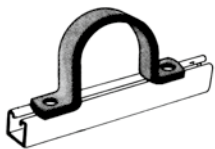

Carbon Steel

	Pipe size (in.)	A (in.)	B (in.)	Thickness (in.)	Width (in.)	Hole size (in.)	Design load lb	Wt./C lb
Diagram	1/2	2 7/8	2	1/8	1 5/8	9/32	650	23
	3/4	3 1/16	2 3/16	1/8	1 5/8	9/32	650	26
	1	3 3/8	2 1/2	1/8	1 5/8	9/32	650	31
	1 1/4	3 11/16	2 13/16	1/8	1 5/8	9/32	650	35
	1 1/2	3 15/16	3 1/16	1/8	1 5/8	9/32	650	39
	2	5 3/4	4 1/8	1/4	1 5/8	7/16	650	94
	2 1/2	6 3/16	4 9/16	1/4	1 5/8	7/16	1,000	114
	3	6 13/16	5 3/16	1/4	1 5/8	7/16	1,000	133
	3 1/2	7 5/16	5 11/16	1/4	1 5/8	7/16	1,000	152
	4	7 13/16	6 3/16	1/4	1 5/8	7/16	1,200	176
	5	8 7/8	7 1/4	1/4	1 5/8	7/16	1,200	198
	6	9 15/16	8 5/16	1/4	1 5/8	7/16	1,200	246

Standard finish – GoldGalv®  
**Example: C708U-1/2**  
 No clearance between pipe and channel.



## Pipe straps, pipe and conduit clamps and hangers

### Conduit and cable clamps



Standard

C711 "J" Pipe hanger

Pipe size (in.)	A rod size (in.)	B (in.)	C (in.)	Overall dimension D (in.)	E (in.)	F (in.)	Bolt size (in.)	G (in.)	Thickness	Width (in.)	Max. rec. load lb	Approx. Wt./C lb
1/2	3/8	2 5/8	1 3/4	7/16	1 1/2	1 15/16	1/4	3 7/32	12 ga	3/4	400	18
3/4	3/8	2 7/8	1 7/8	7/16	1 11/16	2 1/8	1/4	3 1/2	12 ga	3/4	400	21
1	3/8	2 15/16	1 15/16	7/16	1 13/16	2 5/16	1/4	3 11/16	12 ga	3/4	400	22
1 1/4	3/8	3 1/4	2	7/16	2 1/16	2 5/8	1/4	4 1/8	12 ga	3/4	400	25
1 1/2	3/8	3 9/16	2 3/16	7/16	2 7/16	2 7/8	1/4	4 5/8	12 ga	3/4	400	27
2	3/8	3 11/16	2 1/8	7/16	2 9/16	3 1/16	1/4	5	12 ga	3/4	400	29
2 1/2	1/2	4 7/16	2 7/16	9/16	3 3/16	3 5/8	3/8	6	12 ga	1 1/4	500	64
3	1/2	4 13/16	2 9/16	9/16	3 1/2	4 1/16	3/8	6 21/32	12 ga	1 1/4	500	72
3 1/2	1/2	5 1/8	2 5/8	9/16	3 3/4	4 3/8	3/8	7 1/16	3/16	1 1/4	500	84
4	5/8	6 1/8	3 3/16	9/16	4 5/8	5 5/16	3/8	8 9/16	3/16	1 1/4	550	138
5	5/8	6 3/4	3 1/4	9/16	5 1/16	5 5/8	3/8	9 23/32	3/16	1 1/4	550	162
6*	3/4	7 3/4	3 9/16	9/16	5 13/16	6 5/8	3/8	11 1/4	3/16	1 1/4	600	249
8*	7/8	9 3/16	3 11/16	9/16	6 15/16	8	3/8	13 11/16	3/16	1 1/4	760	291

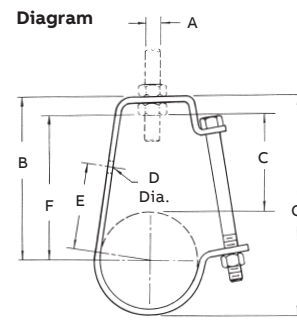

\*Hangers 6 in. and over have hole instead of slot.  
 Standard finishes – GoldGalv®, electrogalvanized (EG)  
 Complies with specification MSS SP69, Type 5. Hole provided for side mounting to wall as bracket.  
**Example: C711-1/2**

## Pipe straps, pipe and conduit clamps and hangers

### Conduit and cable clamps



**C727 Adjustable ring**

Tube size (in.)	Rod size (in.)	A (in.)	B (in.)	C (in.)	Thickness	Width (in.)	Approx max. rec. load	Wt./C lb
½	⅜	3⅜	2⅝	1⅜	16 ga	1	400	9
¾	⅜	3⅜	2½	1⅝	16 ga	1	400	9
1	⅜	3⅜	2⅝	1⅝	16 ga	1	400	9
1¼	⅜	3¾	2⅞	1⅝	16 ga	1	400	10
1½	⅜	3⅞	2⅞	1	16 ga	1	400	11
2	⅜	4¼	3	1	16 ga	1	400	12
2½	½*	5¾	4¼	1⅝	14 ga	1⅜ <sub>16</sub>	600	28
3	½*	6	4⅝	1¼	14 ga	1⅜ <sub>16</sub>	600	30
3½	½*	7⅜	5¼	2⅝	14 ga	1⅜ <sub>16</sub>	600	34
4	⅝*	7⅞	5	2⅝	14 ga	1¼	1,000	37
5	⅝*	9	6⅝	2¼	14 ga	1¼	1,250	83
6	¾**	9⅞	6½	1⅝	14 ga	1¼	1,250	95

**Diagram**

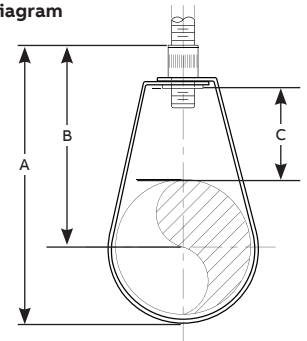

\*⅜ in. nut is used when NFPA rod sizing is requested.

\*\*½ in. nut is used when NFPA rod sizing is requested.

Standard finish – Pregalvanized (no suffix)

Carbon steel. For suspension of non-insulated pipe lines. Complies with specification MSS SP69, Type 10.

**Example: C727-1/2**

# Pipe straps, pipe and conduit clamps and hangers

## Pipe hangers

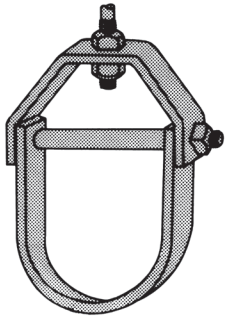

**C710 Adjustable clevis hanger**

Pipe size (in.)	Size of steel (in.)		A (in.)	B (in.)	C (in.)	D (in.)	E (in.)	F (in.)	Max. rec. load, lb	Wt./C lb
	Upper	Lower								
½	½ x 1	½ x 1	¾	1 11/16	2 ½	2 ½	7/8	7/16	610	30
¾	½ x 1	½ x 1	¾	1 7/8	2 7/16	2 ½	1	½	610	32
1	½ x 1	½ x 1	¾	2 ½	2 13/16	2 ½	1 ¼	5/8	610	36
1 ¼	½ x 1	½ x 1	¾	2 9/16	3 7/16	2 ½	1 ¾	7/8	610	42
1 ½	½ x 1	½ x 1	¾	3	4	2 ½	2 ½	1 1/16	610	55
2	½ x 1	½ x 1	¾	3 11/16	4 7/8	2 ½	2 15/16	1 5/8	610	60
2 ½	3/16 x 1 ¼	3/16 x 1 ¼	½	4 11/16	6 1/8	3	3 3/16	2	1,130	115
3	3/16 x 1 ¼	3/16 x 1 ¼	½	4 ¾	6 9/16	3	3 7/8	1 ¾	1,130	132
3 ½	3/16 x 1 ¼	3/16 x 1 ¼	½	4 15/16	6 15/16	3	4 1/16	1 ¾	1,130	156
4	¼ x 1 ¼	3/16 x 1 ¼	5/8	5 9/16	7 13/16	3 ½	4 ½	1 15/16	1,430	190
5	¼ x 1 ¼	3/16 x 1 ¼	5/8	6 3/16	9	3 ½	5 5/8	1 ¾	1,430	240
6	¼ x 1 ½	3/16 x 1 ½	¾	6 13/16	10 5/8	4	5 5/8	1 7/8	1,940	320
8	¼ x 1 ¾	3/16 x 1 ¾	7/8	8 7/16	12 5/8	4 ¼	7	2 ½	1,940	500

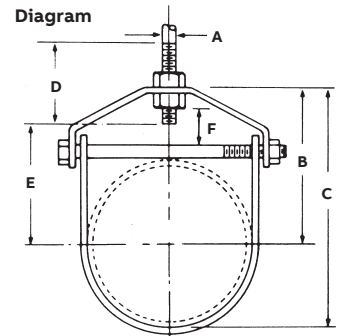

Standard finishes – GoldGalv®, electrogalvanized (EG)  
 Complies with specification MSS SP69, Type 1.  
**Example: C710-1/2EG**

## Pipe straps, pipe and conduit clamps and hangers

### Pipe hangers



CL710 Light-duty adjustable clevis hanger

Pipe size (in.)	Thickness of steel (in.)		A (in.)	B (in.)	C (in.)	D (in.)	E (in.)	F (in.)	Max. rec. load, lb	Wt./C lb
	Upper	Lower								
3/8	16 ga. x 7/8	16 ga. x 7/8	3/8	1 1/8	2 3/16	2 1/2	1 1/4	9/16	150	12
1/2	16 ga. x 7/8	16 ga. x 7/8	3/8	1 3/4	2 3/16	2 1/2	1 1/8	9/16	150	13
3/4	16 ga. x 7/8	16 ga. x 7/8	3/8	1 7/8	2 1/4	2 1/2	1 1/4	1/2	250	15
1	16 ga. x 7/8	16 ga. x 7/8	3/8	2 3/16	2 3/4	2 1/2	1 1/2	3/4	250	18
1 1/4	16 ga. x 7/8	16 ga. x 7/8	3/8	2 5/8	3 3/8	2 1/2	1 3/4	1	250	20
1 1/2	13 ga. x 7/8	13 ga. x 7/8	3/8	3	3 7/8	2 1/2	2 1/4	1 3/16	250	30
2	13 ga. x 7/8	13 ga. x 7/8	3/8	3 3/16	4 3/4	2 1/2	2 13/16	1 5/8	250	38
2 1/2	1/8 x 1 1/4	1/8 x 1 1/4	1/2	4	5 1/2	3	3 1/4	1 3/8	350	80
3	1/8 x 1 1/4	1/8 x 1 1/4	1/2	4 9/16	6 1/2	3	3 9/16	1 1/2	350	89
3 1/2	1/8 x 1 1/4	1/8 x 1 1/4	1/2	5	7	3	4 1/8	1 3/4	350	106
4	3/16 x 1 1/4	1/8 x 1 1/4	1/2	5 1/4	7 1/2	3 1/2	4 1/4	1 7/8	400	146
6	1/4 x 1 1/2	3/16 x 1 1/2	3/4	6 13/16	10 3/8	4	5 5/8	1 7/8	1,940	320
8	1/4 x 1 3/4	3/16 x 1 3/4	7/8	8 3/16	12 5/8	4 1/4	7	2 1/8	1,940	500

Diagram

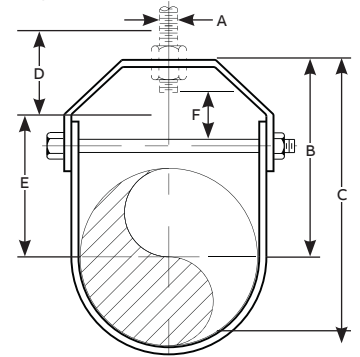

Standard finishes – GoldGalv®, Bare (B), electrogalvanized (EG), fiberglass (FG).

Carbon steel

Used on non-insulated, stationary pipelines. A lock nut above the clevis yoke is required for full rated load.

**Example: CL710-3/8B**

# Pipe straps, pipe and conduit clamps and hangers

## Pipe hangers



**M718 Split pipe ring**

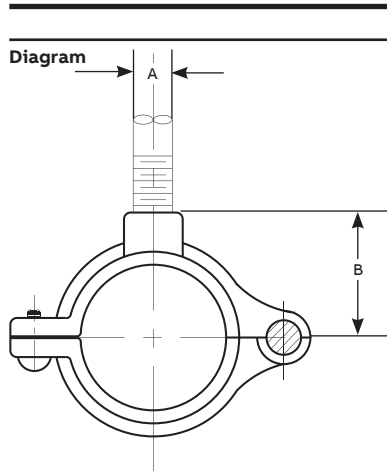

Pipe size (in.)	A (in.)	B (in.)	Max. rec. load, lb	Wt./C approx.
Diagram				
3/8	3/8	1 3/16	180	10
1/2	3/8	7/8	180	13
3/4	3/8	1	180	14
1	3/8	1 1/8	180	16
1 1/4	3/8	1 5/16	180	22
1 1/2	3/8	1 7/16	180	24
2	3/8	1 11/16	180	31
2 1/2	1/2	2 1/8	300	60
3	1/2	2 1/16	300	74
4	1/2	2 15/16	300	116

Standard finishes – Bare (B) or electrogalvanized (EG) malleable iron.

For suspension of non-insulated, stationary pipelines.

**Example: M718-3/8B**

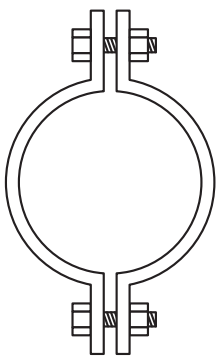

**C725 Medium pipe clamp**

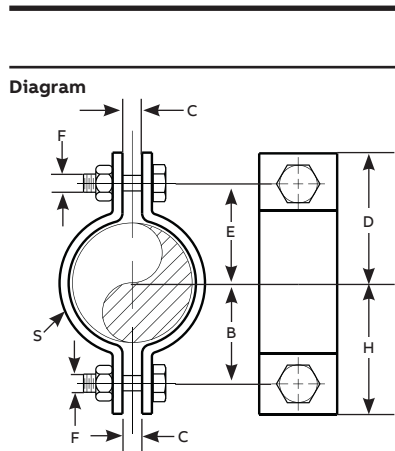

Pipe size (in.)	B (in.)	C (in.)	D (in.)	E (in.)	F (in.)	H (in.)	S (in.)	Max. rec. load, lb	Wt./C approx.
Diagram									
1/2	1	7/16	1 3/8	1	5/16	1 1/2	1/8 x 1	500	29
3/4	1 1/8	7/16	1 3/4	1 1/4	5/16	1 3/4	1/8 x 1	500	32
1	1 1/4	7/16	1 13/16	1 1/4	5/16	1 13/16	1/8 x 1	500	33
1 1/4	1 7/16	7/16	2	1 7/16	5/16	2	1/8 x 1	500	38
1 1/2	1 5/8	1/2	2 1/16	1 1/2	5/16	2 1/4	1/8 x 1	715	39
2	2 1/8	9/16	3 3/8	2 1/4	1/2	3	1/4 x 1	1,040	117
2 1/2	2 5/16	9/16	3 5/16	2 1/2	1/2	3 1/4	1/4 x 1	1,040	128
3	2 3/4	9/16	3 3/4	2 3/4	1/2	3 5/8	1/4 x 1	1,040	140
3 1/2	3 3/8	5/8	3 3/4	3	1/2	3 7/8	1/4 x 1	1,040	145
4	3 5/16	3/4	4 1/4	3 5/16	5/8	4 1/4	1/4 x 1 1/4	1,040	238
6	4 7/8	7/8	5 7/8	5	3/4	5 3/4	3/8 x 1 1/2	1,615	542
8	6	1	7	6 3/8	3/4	6 7/8	3/8 x 1 1/2	1,615	651
10	7 5/16	1	8 3/16	7 1/16	7/8	8 7/16	1/2 x 2	2,490	1,360
12	8 1/4	1	9 3/16	8 7/16	7/8	9 3/8	1/2 x 2	2,490	1,605

Based on the allowable stresses shown in ANSI Code for pressure piping.

For sizes 14 to 24, contact your regional sales office.

Standard finishes – GoldGalv®, Bare (B), electrogalvanized (EG) carbon steel. For suspension of pipelines where little or no insulation is required.

Complies with specification MSS SP69, Type 23.

**Example: C725-1/2B**

# Pipe straps, pipe and conduit clamps and hangers

## Pipe hangers



**C720 Riser clamp**

Diagram	Pipe size (in.)	A (in.)	Thickness (in.)	Width (in.)	Bolt (in.)	Max. rec. load, lb	Wt./ea. approx.
<p>Standard riser</p>	1/2	9 1/8	3/16	1	3/8 x 1 1/2	220	1,01
	3/4	9 1/4	3/16	1	3/8 x 1 1/2	220	1,06
	1	9 3/8	3/16	1	3/8 x 1 1/2	220	1,07
	1 1/4	9 3/4	1/4	1	3/8 x 1 1/2	250	1,12
	1 1/2	10	1/4	1	3/8 x 1 1/2	250	1,20
	2	10 1/2	1/4	1	3/8 x 1 1/2	300	1,25
	2 1/2	11 1/16	1/4	1	3/8 x 1 1/2	400	1,67
	3	11 13/16	1/4	1	3/8 x 1 1/2	500	1,81
	3 1/2	13	1/4	1	1/2 x 1 1/2	600	2,12
	4	13 1/2	1/4	1	1/2 x 1 1/2	750	2,22
	5	14	1/4	1 1/2	1/2 x 1 3/4	1,500	3,44
	6	15 3/16	1/4	1 1/2	1/2 x 1 3/4	1,600	3,65
8	19	3/8	1 1/2	5/8 x 2 1/2	2,500	7,24	

Standard finishes – GoldGalv®, bare (B)  
 Available in sizes 1/2 in. through 10 in.  
 Complies with specification MSS SP69, Type 8.  
**Example: C720-1-1/2B**

**C726 Double bolt pipe clamp**

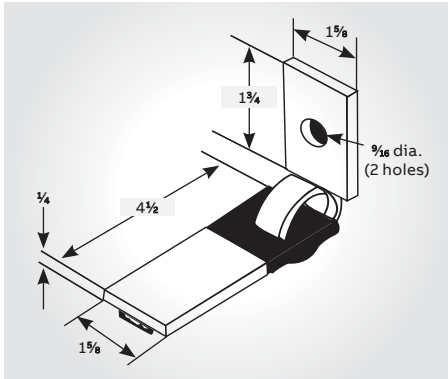

Diagram	Pipe size (in.)	B (in.)	C (in.)	D (in.)	E (in.)	F (in.)	H (in.)	S (in.)	Max. rec. load, lb	Wt./C approx.
	3/4	1 1/16	5/8	3 3/16	2 1/2	3/8	1 11/16	3/16 x 1	950	66
	1	1 1/2	5/8	3 3/4	2 1/2	3/8	2 1/16	3/16 x 1	950	69
	1 1/4	1 1/2	3/4	3 11/16	2 7/8	3/8	2 1/4	3/16 x 1	950	75
	1 1/2	1 13/16	1 1/16	4 7/8	3 3/4	3/8	2 13/16	1/4 x 1 1/4	1,545	181
	2	2 1/4	1 1/16	5 11/16	4 11/16	3/8	3 3/16	1/4 x 1 1/4	1,545	200
	2 1/2	2 5/8	1 1/16	6 1/2	5 3/8	3/8	3 1/2	1/4 x 1 1/4	1,545	232
	3	2 3/4	1 1/16	6 7/8	6	3/8	3 3/4	1/4 x 1 1/4	1,545	258
	3 1/2	3	1 1/16	7 1/16	6 3/16	3/8	4	1/4 x 1 1/4	1,545	264
	4	3 3/8	1 1/16	7 3/8	6 1/2	3/4	4 1/2	3/8 x 2	2,500	750
	5	3 15/16	1 1/16	8 3/8	7	3/4	5	3/8 x 2	2,500	813
	6	4 3/4	1 1/16	9 15/16	8 3/16	1	6 3/8	3/8 x 2 1/2	2,865	1311
	8	5 3/4	1 1/16	10 15/16	9 3/16	1	7 3/8	3/8 x 2 1/2	2,865	1467

Standard finish – bare (B)  
 carbon steel. For the suspension of insulated pipelines.  
 Normally used with weldless eye nut.  
**Example: C726-1/2B**

## Pipe straps, pipe and conduit clamps and hangers

### Seismic bracing



01

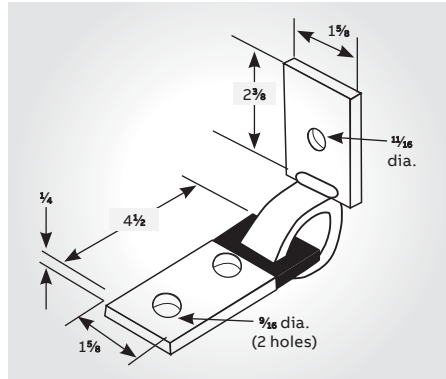

02

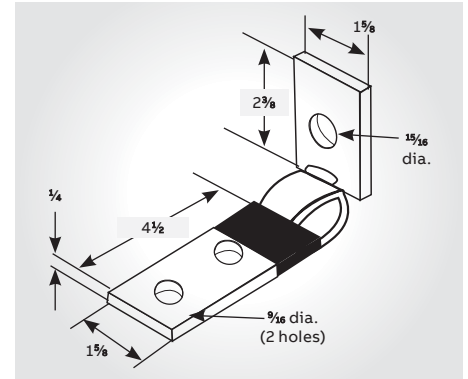

03

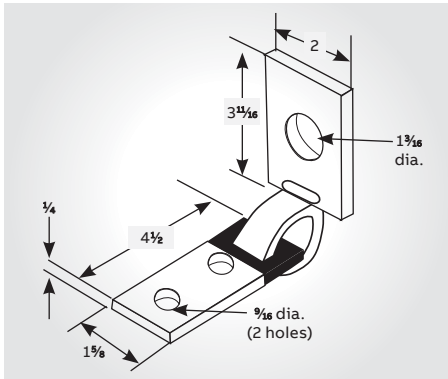

04

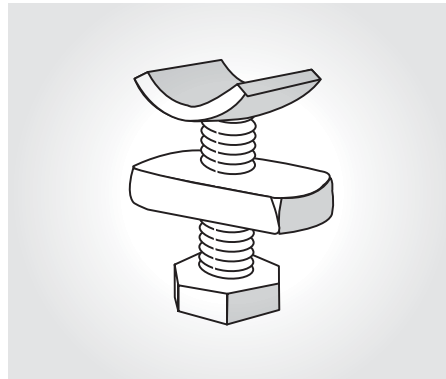

05

01 **C749N Seismic brace**  
Standard finish  
– GoldGalv®  
1650 lb load  
Safety factor 3  
Wt./C 61 lb

02 **C749N-5/8 Seismic brace**  
Standard finish  
– GoldGalv®  
1650 lb load  
Safety factor 3  
Wt./C 56 lb

03 **C749N-7/8 Seismic brace**  
Standard finish  
– GoldGalv®  
1650 lb load  
Safety factor 3  
Wt./C 74 lb

04 **C749N-1 1/8 Seismic brace**  
Standard finish  
– GoldGalv®  
1650 lb load  
safety factor 3  
Wt./C 72 lb

05 **ES142**  
Standard finish  
– GoldGalv®

Cat. no.	Bolt dia.	Wt./C lb
ES-142-1/2 x 1-1/2	1/2	21

Seismic bracing rod  
stiffener connector.  
Wt./C 21 lb

All dimensions shown are in in.

All braces have  
plastisol coating  
on the flat member.  
Plastisol insulates  
against vibration noise  
transmission and  
eliminates rattle at  
the connection points.

## — Hanger accessories

Other products available. Contact your regional sales office.



01

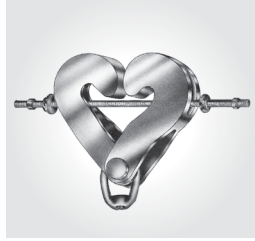

02



03

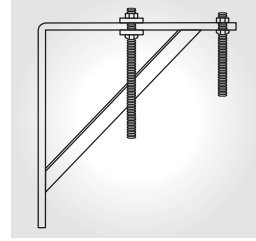

04

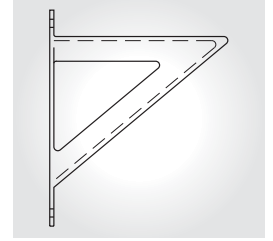

05

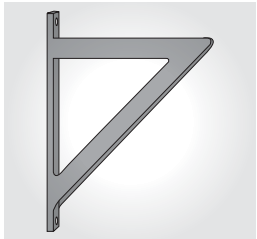

06

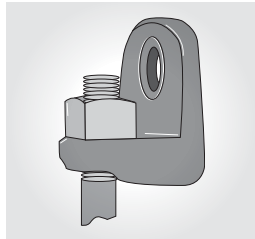

07



08



09



10

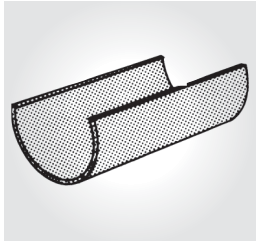

11



12

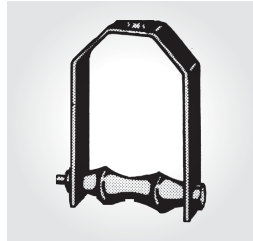

13



14

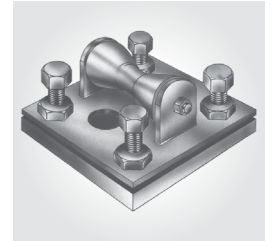

15

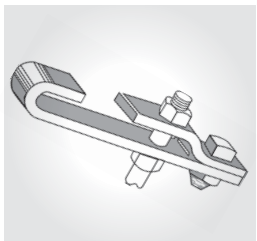

16

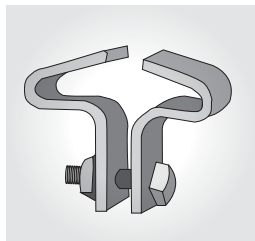

17

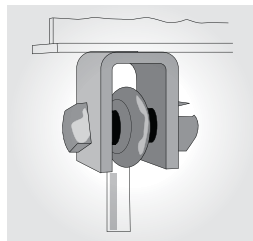

18

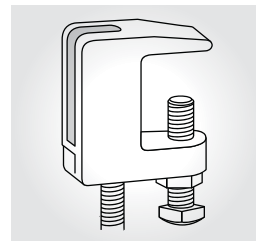

19

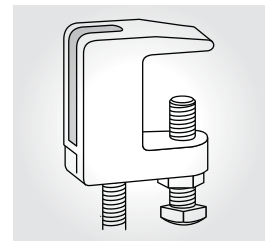

20

01 C704A Offset J-hook  
Sizes ½ in. through 3 in. IPS

02 M732H I-beam with eye nut  
MSS SP69 Type 28

03 M732/M732 Ext I-beam clamp with swing nut  
Sizes ¾ in. through ¾ in. Rod  
MSS SP69 Type 30

04 C736 Light welded steel bracket  
Max. load 750 lb  
MSS SP69 type 31

05 C739M Medium welded steel bracket  
Max. load 1,500 lb  
MSS SP69 type 32

06 C739H Heavy welded steel bracket  
Max. load 3,000 lb  
MSS SP69 type 33

07 M750 Side beam bracket  
Sizes ¾ in. through ¾ in. rod  
MSS SP69 type 34

08 C785A Pipe stanchion saddle  
Sizes 4 in. through 36 in. IPS  
MSS SP69 type 37

09 C786 Adj. pipe saddle support  
Sizes 2½ in. through 36 in. IPS  
MSS SP69 type 38

10 C789 Steel pipe covering protection saddle  
MSS SP69 type 39

11 C790 Insulation protection shield for PVC-coated pipe lines and insulated copper tubing  
Sizes ¾ in. through 12 in. IPS  
MSS SP69 type 40

12 RC729A Single pipe roll  
Sizes 1 in. through 24 in. IPS  
MSS SP69 type 41

13 C729 Adj. roller hanger  
Sizes 1 in. through 20 in. IPS  
MSS SP69 type 43

14 S730C Pipe roll + base  
MSS SP69 type 44

15 S730D Adj. pipe roll & base  
MSS SP69 type 46

16 C769 Top I-beam clamp  
Sizes ¾ in. through ¾ in. rod  
MSS SP69 type 25

17 C755 T/C757 T Center I-beam clamp  
MSS SP69 type 21

18 C780 Weld attachment as shown or inverted less bolt  
MSS SP69 type 22

19 M778 Top beam C-clamp  
Sizes ¾ in. through ¾ in. rod  
MSS SP69 type 19

20 M777 Junior top beam C-clamp  
Sizes ¾ in. through ¾ in. rod  
MSS SP69 type 18



## Surface raceway and lighting systems

### Material

Superstrut electrical raceway, fixture hanging channel, closure strip and accessories are manufactured from hot-rolled strip steel. Standard finish for the accessories is GoldGalv®.

### Design data

Deflections at various hanger rod spacings for raceway channels based on 40 to 45 lb per fixture.

Deflection			
Channel	at 10 ft. (in.)	at 12 ft. (in.)	at 14 ft. (in.)
A1200	¼	½	¾
C1200	⅝	¾	*
A1400	⅝	¾	*

Deflection			
Channel	at 6 ft. (in.)	at 7 ft. (in.)	at 9 ft. (in.)
B1200	⅝	⅞	5/8
B1400	1	½	*

\*Not recommended for this spacing.

### Electrical raceway

Superstrut channel together with snap-in closure strip is listed by Underwriters Laboratories as a surface metal raceway. Other accessories listed by Underwriters Laboratories are identified on the drawings.

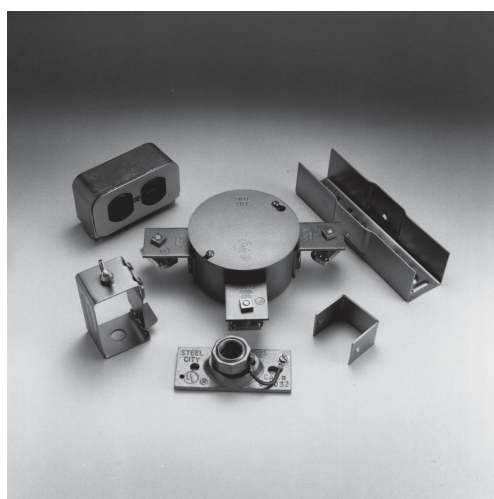

### Maximum number of wires

Wire size AWG	Raceway							
	With or without KO							
	A1200 A1400		B1200 B1400		C1200		E1200 H1200	
	A	B	A	B	A	B	A	B
14	6	10	4	6	5	10	6	10
12	6	10	3	6	4	10	6	10
10	5	8			4	6	5	8
8	4	6			3	4	4	6
6	2	3			2	2	2	3

**Column A:** Suitable for number of wires indicated when used as a raceway. Also suitable for number of wires indicated when installed to support and supply electrical fixtures when raceway wiring is suitable for not less than 75 °C.

By providing clearance between fixture and raceway of not less than ½ in., where suitable for 60°C may be used.

**Column B:** Suitable for number of wires indicated when used as a raceway. Also suitable for number of wires indicated when installed to support electrical fixtures when clearance of not less than ⅝ in. is provided between raceway and fixture and when wiring is suitable for 75 °C.

### Applicable channels

A1200	B1200
A1200-KO	B1400
A1400	C1200
A1400-KO	E1200
	H1200



## Surface raceway and lighting systems

### Fixture fittings

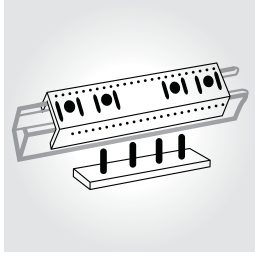

01

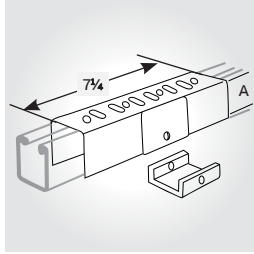

02

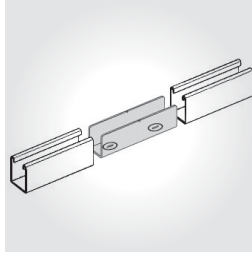

03

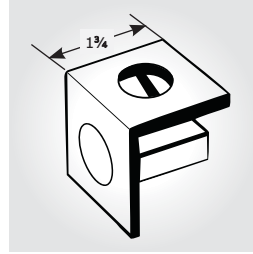

04

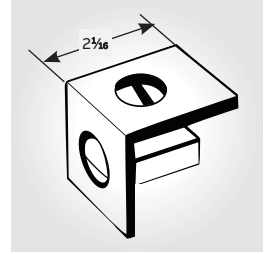

05

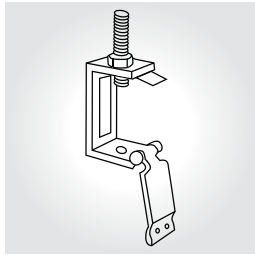

06

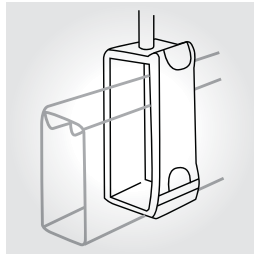

07

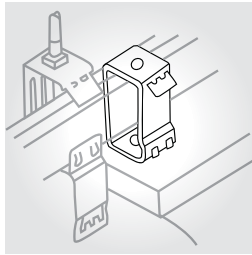

08

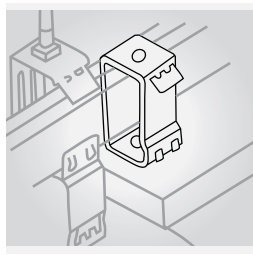

09

01 **802 Raceway joiner with reinforcing plate**  
Furnished complete with nuts.

Cat. no.	For channel	Wt./C lb
A802EG	A series	158
B802EG	B series	112
E802EG	E series	170
H802	H series	182

02 **822 Raceway joiner and seal**  
Furnished complete with 1/4 in. x 3/8 in. machine screws and AB100-1/4 nuts.

Cat. no.	A (in.)	For channel	Wt./C lb
A822	1 1/16	A series	75
B822	7/8	B series	56

03 **A213 Inside joiner**  
For A1200 series channel. Only available in GoldGalv® finish.

04 **805 End cap with knockout**  
KO for 1/2 in. conduit. Furnished complete with 1/4 in. x 3/8 in. flat head machine screw and AB100-1/4 nut.

Cat. no.	For channel	Wt./C lb
A805EG	A series	21
H805EG	H series	31

All dimensions shown are in in.

05 **809 Tapped end cap**  
12 ga. steel. For 3/4 in. or 1 in. conduit. Furnished complete with 1/4 in. x 3/8 in. flat head machine screw and AB100-1/4 nut.

Rod size	For channel	Wt./C lb
A809-3/4EG	A series	2
E809-3/4EG	E series	26

06 **A853 Channel hanger**  
Use hanger rod 3/8 in. or 1/2 in. Use with A, AR, B, BR or C series single channel. Wt./C 25 lb

07 **A853L Channel hanger – long**  
Long type for all series channel. Wt./C 48 lb

08 **A854 Channel hanger**  
Illustration showing A854 with nut and bolt furnished to attach to fluorescent fixture. Use with A, B, C or D series channel. Wt./C 34 lb

09 **A854L Channel hanger – long**  
Illustration showing A854L with nut and bolt furnished to attach to fluorescent fixture. Use with E and H series channel as well as A, B, C or D series channel. Wt./C 51 lb

# Surface raceway and lighting systems

## Fixture fittings

**Pre-galvanized steel closure strip**  
 AB844PGC  
 AB844PGCWH White epoxy powder coated

**Plastic closure strip**  
 AB844PC Color: Gold  
 AB844PCGY Color: Grey

- When used as a raceway, channel is normally installed with the slot up. After wiring has been completed the closure strip is installed.
- For all channels.
- Standard length: 10 ft.

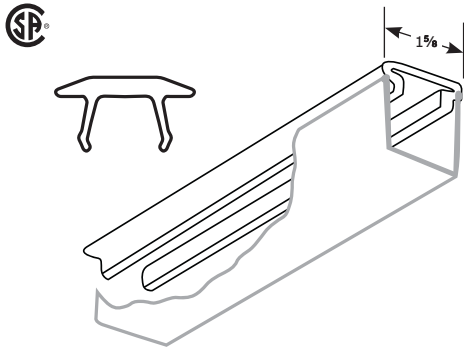

**Stainless steel closure strip**  
 AB844SS6CS

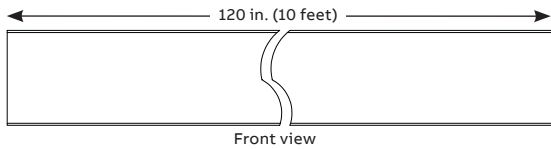

Note: Strapping not included.

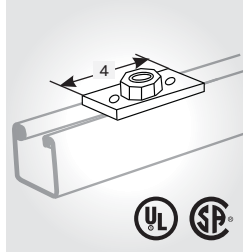

01

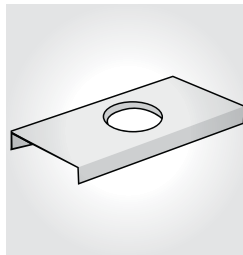

04

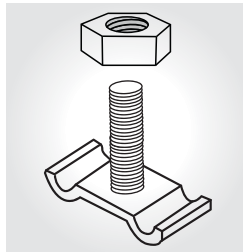

07

**01 AB803 Cast conduit connector**  
 To connect 1/2 in. or 3/4 in. conduit to raceway channel. Furnished complete with stud nuts and hex nuts. Part has removable bushing to increase size from 1/2 in. to 3/4 in.  
 Wt./C 60 lb

**02 AB815 Swing connector**  
 Nuts and bolts to clamp to channel is included. For 1/2 in. or 3/4 in. conduit.  
 Wt./C 95 lb

**03 AB885 15° Swivel**  
 Nuts and bolts to clamp to channel included. For 1/2 in. or 3/4 in. conduit.  
 Wt./C 25 lb

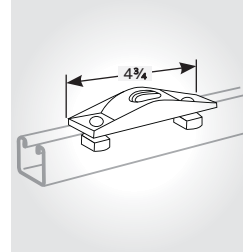

02

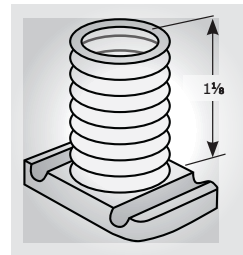

05

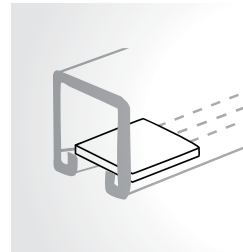

08

**04 AB867 Spacer**  
 For use with AB866 wiring stud nuts.  
 Wt./C 24 lb

**05 AB866 Wiring stud nut**  
 1/2 in. pipe thread  
 Wt./C 21 lb

**06 811 Stud nut**

For		
Cat. no.	channel	Wt./C lb
811-1STR	1/4 x 1	8
811-2STR	1/4 x 1 1/4	9

All dimensions shown are in.

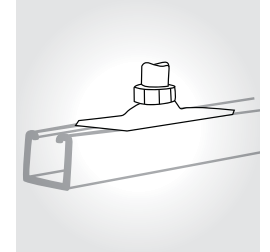

03

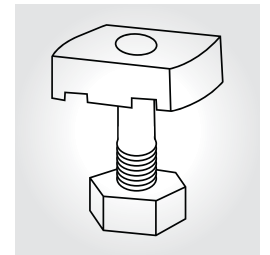

06

**07 812 Stud nut**  
 For attaching fixture to slot-down channel or to slot-up knockouts. Specify length. Hex nut included.

For		
Cat. no.	channel	Wt./C lb
812-1EG	1/4 x 1	6

**08 AB868 Fiber retainer for cables**  
 Until closure strip is installed  
 Std. pack 100  
 Wt./C 3 lb

## Surface raceway and lighting systems

Kindorf® channel boxes and receptacles

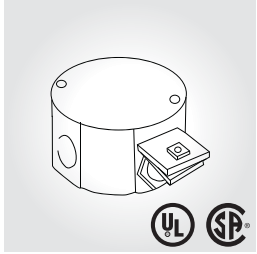

01

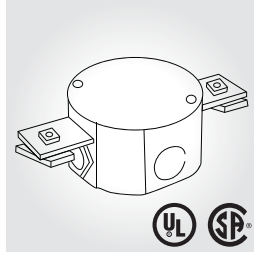

02

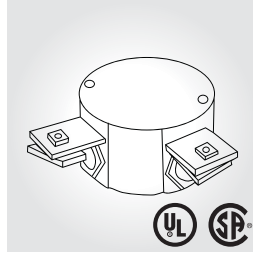

03

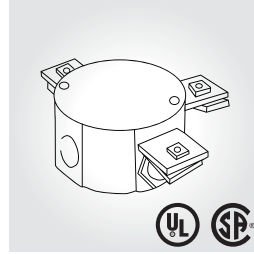

04

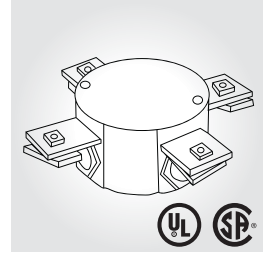

05

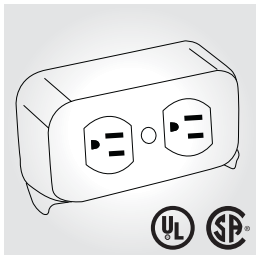

06

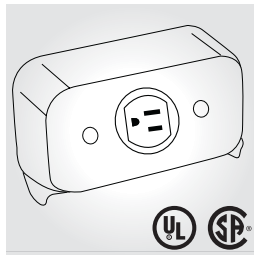

07



08



09

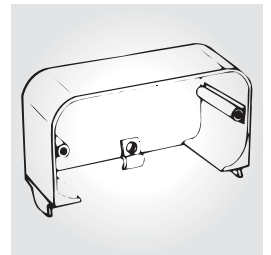

10

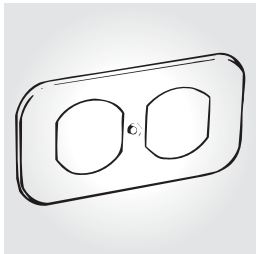

11

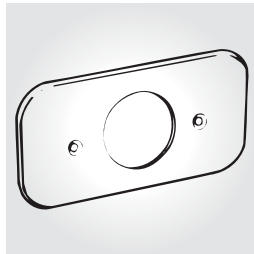

12

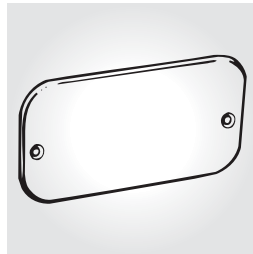

13

01 **G2000**  
Finish – GoldGalv®  
Wt./C 110 lb

02 **G2001**  
Finish – GoldGalv®  
Wt./C 120 lb

03 **G2002**  
Finish – GoldGalv®  
Wt./C 120 lb

04 **G2003**  
Finish – GoldGalv®  
Wt./C 130 lb

05 **G2004**  
Finish – GoldGalv®  
Wt./C 140 lb

06 **G1038 Duplex outlet**  
Complete unit including housing, standard duplex 3-wire, 15 amp., 125 volt, ground receptacle and cover plate.  
Finish – GoldGalv®  
Wt./C 55 lb

07 **G1038A Single outlet**  
Complete unit including housing, standard single 3-wire, 15 amp., 125 volt, ground receptacle and cover plate.  
Finish – GoldGalv®  
Wt./C 50 lb

08 **G1038D Raceway outlet**  
Complete unit including housing, duplex, 3-wire, 15 amp., 277 volt-twistlock receptacle and cover plate.  
Finish – GoldGalv®  
Wt./C 60 lb

09 **G1038E Raceway outlet**  
Complete unit including housing, single, 3-wire, 15 amp., 277 volt-twistlock receptacle and cover plate.  
Finish – GoldGalv®  
Wt./C 50 lb

10 **G1038B Housing only**  
Finish – GoldGalv®  
Wt./C 25 lb

11 **G1038C Duplex cover plate**  
Finish – GoldGalv®  
Wt./C 12 lb

12 **G1038CA Single cover plate**  
Size of opening: 1.391 in. diameter  
Finish – GoldGalv®  
Wt./C 14 lb

13 **G1038CX Blank cover plate**  
Finish – GoldGalv®  
Wt./C 15 lb

# Surface raceway and lighting systems

## Kindorf® fixture accessories

### G1017 Mercury vapor hanger

Used with channel	Depth (in.)	Wt./C lb
A-1200	4 1/4	76

Finish – GoldGalv®  
 To support high or low bay mercury vapor or heavy incandescent fixtures from raceway channels. Permits plug-in connections with G-1038 raceway outlets

#### Diagrams

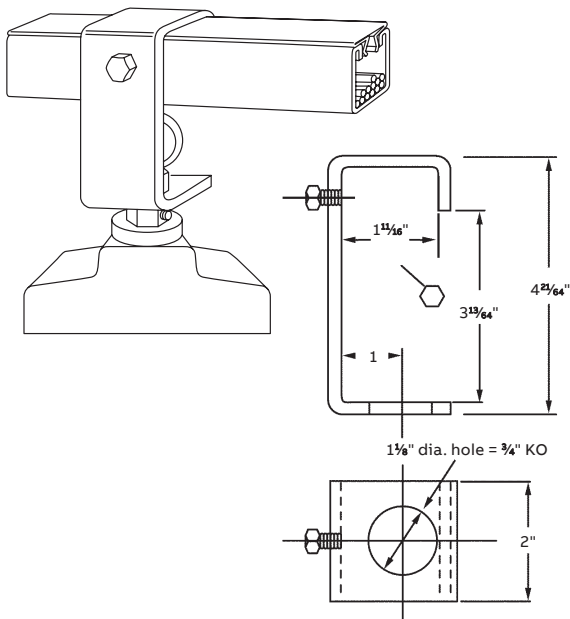

### G972HB1/2 Steel fixture hanger adapter

Finish – GoldGalv®  
 The hanger adapter securely mounts the fixture hanger or box to the channel through the 1/2 in. KO in the base. No special tools are needed for installation of fittings and fixtures.  
 Superstrut channels, with 1/2 in. KO's every 6 in., hangs and feeds the fixtures, thereby simplifying installation.  
 Wt./C 17 lb

#### Diagrams

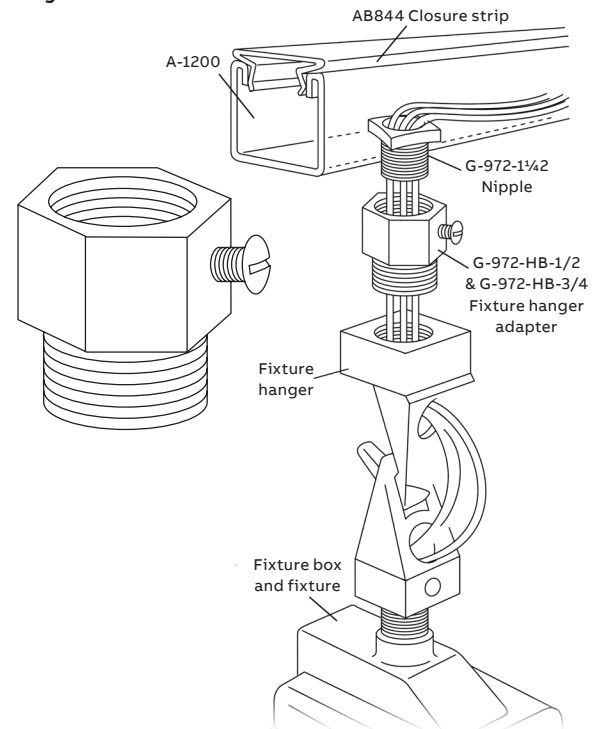

#### Electrical applications

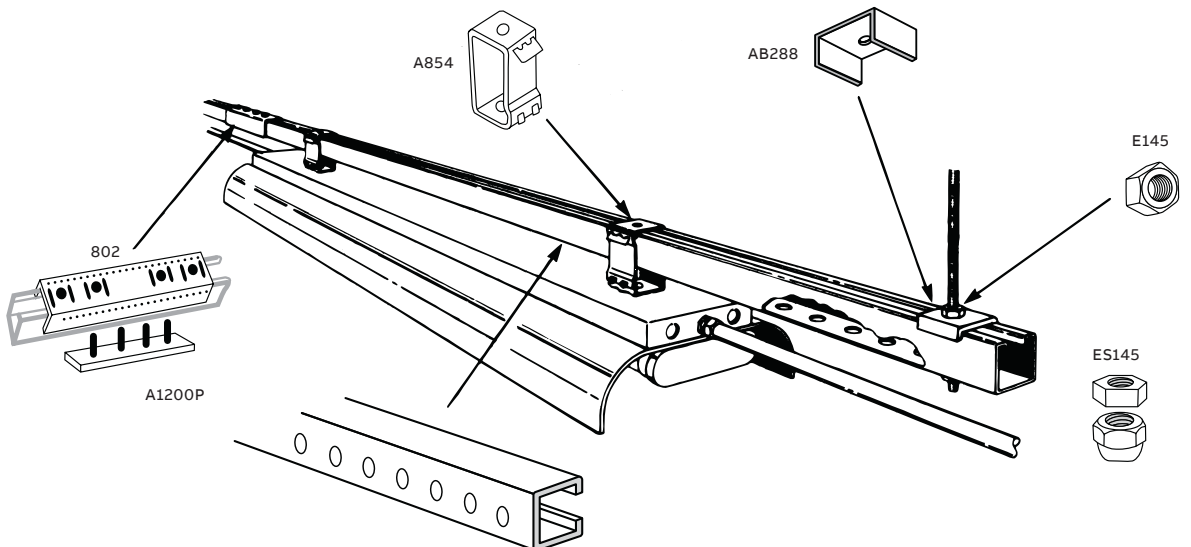

# Surface raceway and lighting systems

## Electrical applications

### Electrical applications

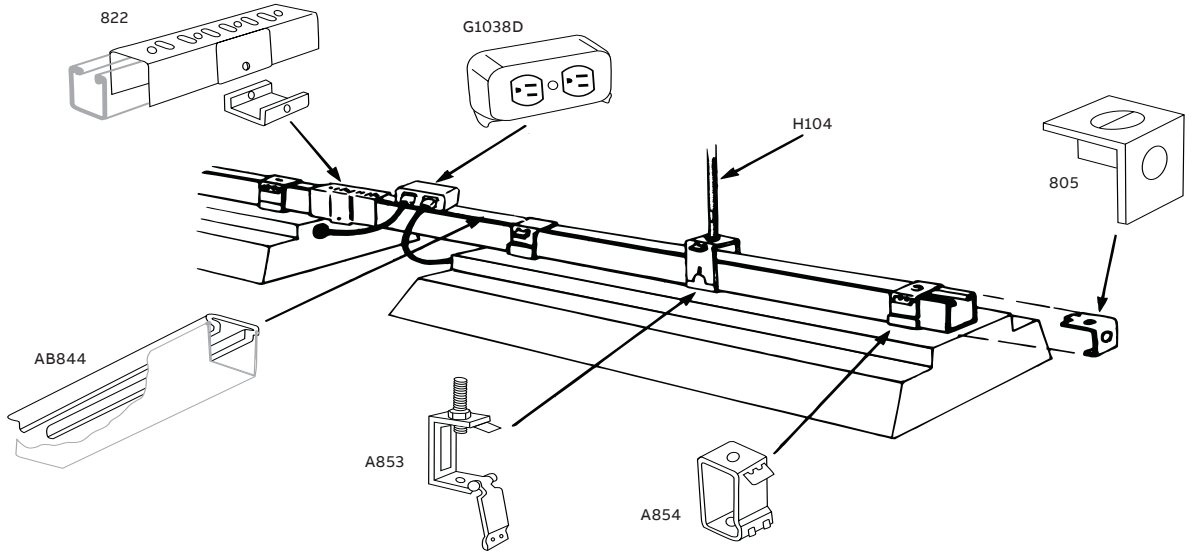

### Electrical applications

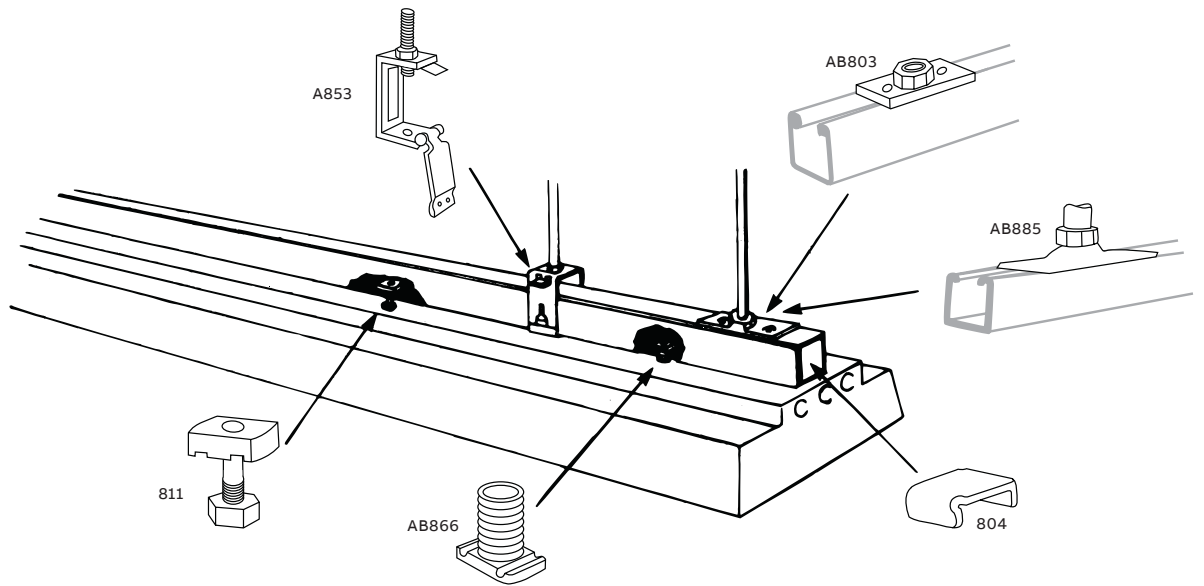

# Surface raceway and lighting systems

## Electrical applications

Electrical applications

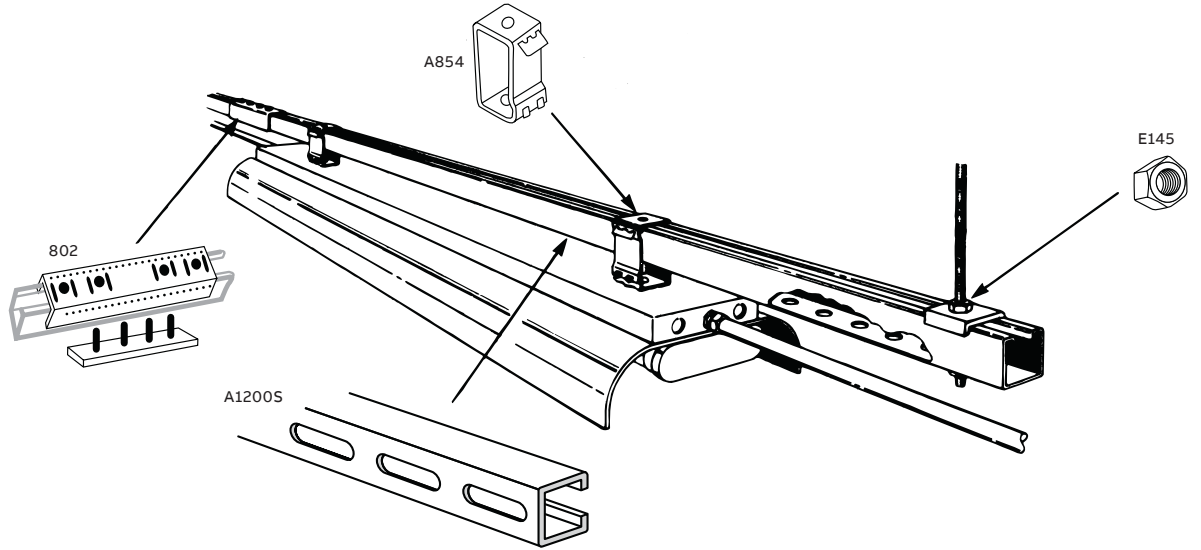

Electrical applications

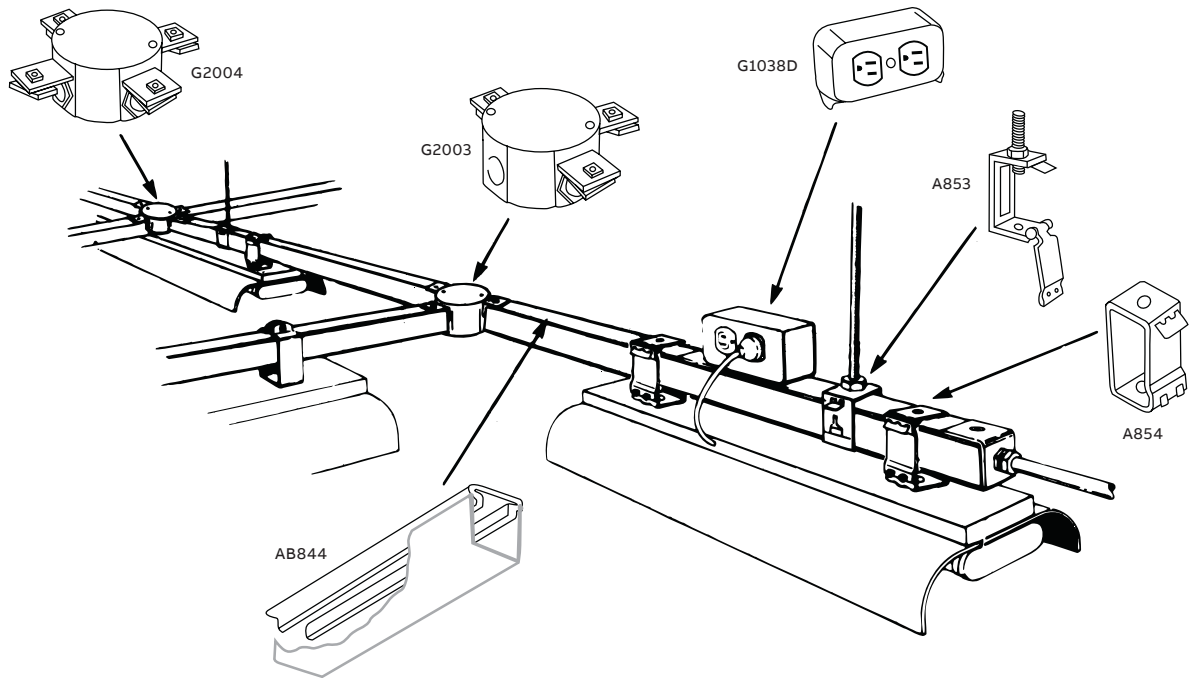

## Right angle slotted metal framing

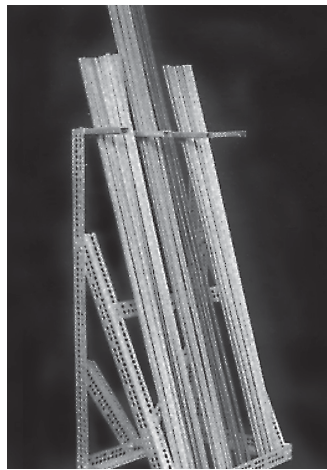
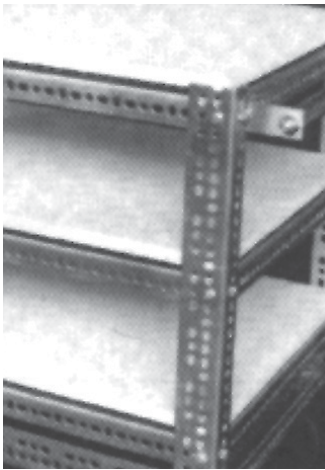
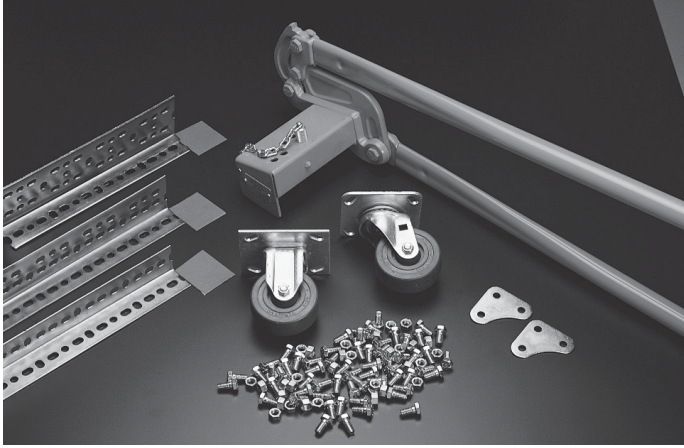

### Create the support framing you need

Right angle metal framing is manufactured from commercial quality steel in three different sizes. The small sizes are 14 ga. steel, the larger is 12 ga. steel. With this offering, an endless variety of metal framing requirements can be met, from lightweight supporting needs to larger shelving for inventory storage.

One of the legs on all sizes is  $1\frac{1}{8}$  in. wide, while the other is either  $1\frac{1}{2}$  in.,  $2\frac{3}{8}$  in. or  $3\frac{1}{2}$  in. long. Depending on the frame requirements, a single size can be utilized throughout, or the sizes can be interchanged to get the most efficient usage from the material. This section will serve as a guide to plan and build your structure.

### Installation time is reduced – inventory space is minimal

Scribe marks are placed every  $\frac{3}{4}$  in. which saves planning, layout and cutting time and ensures accuracy. The exclusive slot and hole pattern, repeated every 3 in., is scientifically designed for ease of assembly and rigidity. No welding is necessary, no holes to drill. A  $\frac{9}{16}$  in. wrench is the only tool required for assembly. The proper nuts and bolts are included with the material to ensure fast and easy erection.

Right angle metal framing is packaged in 10' and 12' lengths to minimize cut offs and ensure maximum use of material.

120 feet, 10, 12 foot lengths of right angle metal framing take up the same amount of space as one 2x4. A standard package includes 5 pieces to a bundle, significantly reducing handling and storage space.

The importance of cutting right angle easily, quickly and accurately is the key to time-saving assembly. The portable cutter provides these advantages and makes layout and erection of any structure a "light-work" job.

### Finish is designed for long lasting durability

The standard GoldGalv<sup>®</sup> hardware finish is applied to all right angle metal framing after rolling and punching of the holes. This provides you with a number of benefits. First, raw ends resulting from cuts will be protected by the sacrificial quality of zinc. Second, the edges of all holes are protected against formation of rust, to provide a call-back-free installation. Third, the electrogalvanizing provides an excellent bonding surface for paint if desired for aesthetic reasons.

Note: Product is also available in pregalvanized (PG) sections.



## Right angle slotted metal framing

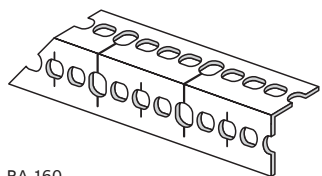

RA-160  
14 gauge

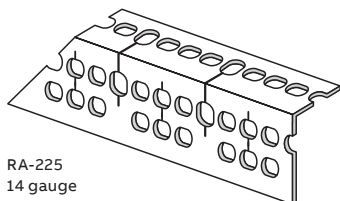

RA-225  
14 gauge

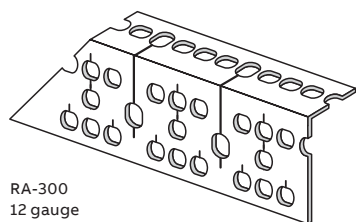

RA-300  
12 gauge

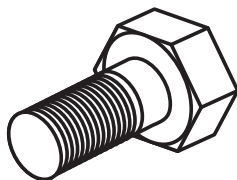
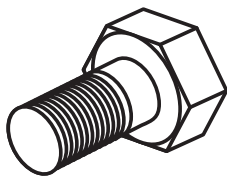
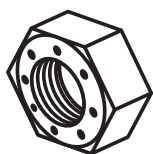

Cat. no.	Length ft.	No. of ft./per pkg.
RA-160-10	10	50
RA-160-12	12	60
RA-225-10	10	50
RA-225-12	12	60
RA-300-10	10	50
RA-300-12	12	60

Each package includes 36 nuts and bolts.

### Extra nuts and bolts

Cat. no.	Package 100 sets	Std. ctn.
RA-BN-5/8 Use with RA-160 & RA-225	2 $\frac{3}{8}$ in.–16 x 1 $\frac{1}{8}$ in.	100
RA-BN-3/4 Use with RA-300	2 $\frac{3}{8}$ in.–16 x $\frac{3}{4}$ in.	100

### Rigid and swivel casters

Cat. no.	Package	Std. ctn.
RA-GP	25	100
RA-RC	2	2
RA-SC	2	2
RA-C	1	1

Hard rubber composition 3 $\frac{1}{2}$  in. dia. with load rating of 225 lb per wheel.

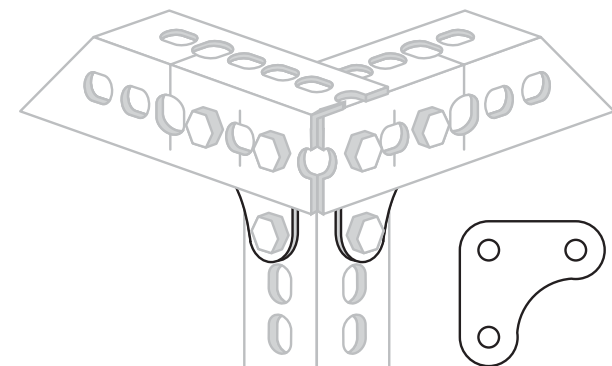

RA-GP  
Gusset plate  
for extra rigid assembly

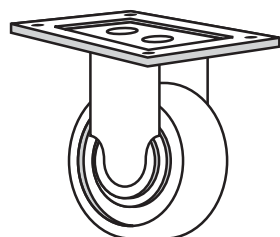

RA-RC

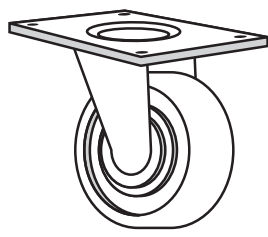

RA-SC

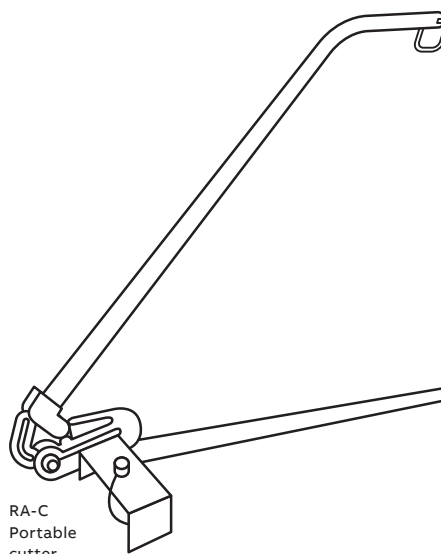

RA-C  
Portable  
cutter

## Engineering data and specifications

### Design data – metal framing channel

Table 1

#### Elements of sections properties for design

##### Nominal thickness (inches)

12 ga = 0.105

14 ga = 0.075

16 ga = 0.060

##### Legend

I Moment of inertia

S Section Modulus

r Radius of Gyration

Z Nominal Axis

A Area

#### Diagrams

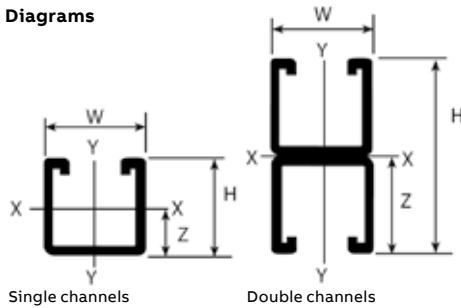

Single channels

Double channels

Section member	Wt. lb/ft.	H (in.)	W (in.)	A (in.) <sup>2</sup>	I (in.) <sup>4</sup>	S (in.) <sup>3</sup>	X-X axis			Y-Y axis	
							r (in.)	Z (in.)	I (in.) <sup>4</sup>	S (in.) <sup>3</sup>	r (in.)
<b>Single channel</b>											
A1200	1.90	1.625	1.625	0.557	0.192	0.212	0.587	0.719	0.237	0.292	0.652
B1200	1.28	0.813	1.625	0.381	0.031	0.063	0.283	0.331	0.137	0.168	0.600
C1200	1.70	1.375	1.625	0.500	0.121	0.155	0.492	0.595	0.205	0.252	0.640
D1200	1.44	1.000	1.625	0.424	0.053	0.092	0.356	0.403	0.159	0.196	0.616
E1200	2.47	2.438	1.625	0.726	0.529	0.399	0.853	1.112	0.335	0.413	0.679
H1200	3.05	3.250	1.625	0.897	1.100	0.635	1.107	1.507	0.436	0.536	0.697
A1400	1.40	1.625	1.625	0.401	0.134	0.146	0.577	0.707	0.184	0.226	0.677
B1400	0.97	0.813	1.625	0.280	0.024	0.051	0.295	0.338	0.103	0.127	0.607
<b>Double channel</b>											
A1202	3.80	3.250	1.625	1.114	0.948	0.583	0.992	1.625	0.474	0.584	0.652
B1202	2.56	1.626	1.625	0.762	0.147	0.181	0.439	0.813	0.274	0.337	0.600
C1202	3.40	2.750	1.625	1.000	0.595	0.433	0.772	1.375	0.409	0.504	0.640
D1202	2.88	2.000	1.625	0.847	0.257	0.257	0.552	1.090	0.319	0.393	0.616
E1202	4.94	4.876	1.625	1.450	2.854	1.171	1.402	2.438	0.672	0.827	0.680
H1202	6.10	6.500	1.625	1.794	6.273	1.930	1.870	3.250	0.871	1.072	0.697
A1402	2.80	3.250	1.625	0.801	0.668	0.411	0.913	1.625	0.367	0.452	0.677
B1402	1.94	1.626	1.625	0.560	0.112	0.138	0.447	0.813	0.206	0.254	0.607

Table 2

#### Maximum pullout and slip loads for steel channel and channel nuts

Channel nuts size/thread	Channel all series	Pull out strength		Slip resistance			Torque
		lb	kN	lb	kN	Ft-lb	Nm
¼-20		600	2.7	300	1.3	6	8
⅜-18	A1200	800	3.6	500	2.2	11	15
	B1200						
⅝-16	C1200	1,000	4.4	800	3.6	19	25
	D1200	2,000	8.9	1,500	6.7	50	70
¾-11	E1200	2,500	11.1	1,500	6.7	100	135
	H1200	2,500	11.1	1,700	7.6	125	170
¼-20		600	2.7	300	1.3	6	8
⅜-18	A1400	800	3.6	400	1.8	11	15
	B1400	1,000	4.4	750	3.3	19	25
½-13		1,400	6.2	1,000	4.4	50	70

For aluminum channel the pull out load is calculated by multiplying the appropriate data by 50%. For slip resistance multiply by 75%.

#### Maximum pullout and slip loads for fiber glass channel and channel nuts

Channel nuts size/thread	Channel all series	Pull out strength		Slip resistance			Torque
		lb	kN	lb	kN	Ft-lb	Nm
¼-20	-	-	-	-	-	-	-
⅜-18	-	-	-	-	-	-	-
⅝-16	A1200	300	1.3	150	0.6	200	22.6
	D1200	300	1.3	150	0.6	200	22.6

## Engineering data and specifications

### Design data – metal framing channel

Table 3

#### Design loads for channel used as beam or column

##### Beam loads

Table 3 contains simple beam, uniformly distributed loads calculated at 25,000 psi material stress. Beam loads are based on channel being loaded across the X-X axis. Loads are also listed at reduced deflections for long spans.

##### Maximum loads at 25,000 psi stress

Maximum allowable deflections and maximum uniform loads for all spans at 25,000 psi material stress.

##### Reduced load for all $\frac{1}{180}$ span deflection

For moderate deflections on the longer spans, reduced loads are listed which will produce a deflection equal to  $\frac{1}{180}$  of the span. When maximum loads do not induce deflections exceeding  $\frac{1}{180}$  x the span length, reduced loads are not required.

##### Reduced load for $\frac{1}{360}$ span deflection

For very slight deflections on the longer spans, reduced loads are listed which will produce a deflection equal to  $\frac{1}{360}$  of the span. When maximum loads do not induce deflections exceeding  $\frac{1}{360}$  x the span length, reduced loads are not required.

##### Concentrated loads

To obtain values for concentrated loads from Table 3, multiply uniform load by 0.5 and deflection by 1.25.

#### Slotted, punched or KO channel

Reduce load rating by 5%.

#### Long span deep beams

Support in a manner to prevent rotation at supports and tie between supports to prevent twist.

#### Column loads

Allowable column loads given are for uniform axial loading with pinned ends. For eccentric loading or other end conditions reduce allowable loads according to standard engineering practice.

#### Dynamic loads

Allowable dynamic loads may be calculated by dividing the static loads shown in Table 3, by 2.08. Maximum beam and column loading for special materials is multiplied with the following factors:

Channel type	Beam type	Column load
Stainless steel	1	1
Aluminum	0.33	0.33

#### Warning

**Load tables, charts and design criteria provided in this section are intended as guides only. Selection of proper product, installation intervals, erection and placement are the responsibility of the user.**

**ABB reserves the right to change material and finish specifications without notice, to improve its products.**

## Engineering data and specifications

### Design data – metal framing channel

Table 3 (cont'd)

Single channel										
Cat. no.	Depth (in.)	Ga.	Maximum uniform			$\frac{1}{160}$ Span		$\frac{1}{500}$ Span		Col. load
			Load	Defl.	Load	Defl.	Load	Defl.		
<b>12 in. beam or column</b>										
A1200	1 $\frac{5}{8}$	12	3,534	0.014	–	0.067	–	0.033	10,533	
B1200	1 $\frac{3}{16}$	12	1,050	0.026	–	0.067	–	0.033	6,683	
C1200	1 $\frac{3}{8}$	12	2,584	0.016	–	0.067	–	0.033	9,345	
D1200	1	12	1,538	0.022	–	0.067	–	0.033	8,670	
E1200	2 $\frac{7}{16}$	12	6,650	0.010	–	0.067	–	0.033	13,830	
H1200	3 $\frac{1}{4}$	12	10,583	0.008	–	0.067	–	0.033	17,106	
A1400	1 $\frac{5}{8}$	14	2,434	0.015	–	0.067	–	0.033	7,575	
B1400	1 $\frac{3}{16}$	14	850	0.028	–	0.067	–	0.033	4,950	
<b>18 in. beam or column</b>										
A1200	1 $\frac{5}{8}$	12	2,355	0.033	–	0.100	–	0.050	10,210	
B1200	1 $\frac{3}{16}$	12	700	0.059	–	0.100	–	0.050	6,058	
C1200	1 $\frac{3}{8}$	12	1,723	0.038	–	0.100	–	0.050	8,970	
D1200	1	12	1,025	0.052	–	0.100	–	0.050	7,930	
E1200	2 $\frac{7}{16}$	12	4,434	0.023	–	0.100	–	0.050	13,482	
H1200	3 $\frac{1}{4}$	12	7,055	0.016	–	0.100	–	0.050	16,693	
A1400	1 $\frac{5}{8}$	14	1,623	0.031	–	0.100	–	0.050	7,334	
B1400	1 $\frac{3}{16}$	14	566	0.063	–	0.100	453	0.050	4,150	
<b>24 in. beam or column</b>										
A1200	1 $\frac{5}{8}$	12	1,766	0.058	–	0.133	–	0.067	9,842	
B1200	1 $\frac{3}{16}$	12	525	0.105	–	0.133	333	0.067	5,315	
C1200	1 $\frac{3}{8}$	12	1,291	0.066	–	0.133	–	0.067	8,545	
D1200	1	12	769	0.087	–	0.133	490	0.067	7,050	
E1200	2 $\frac{7}{16}$	12	3,325	0.039	–	0.133	–	0.067	13,082	
H1200	3 $\frac{1}{4}$	12	5,291	0.030	–	0.133	–	0.067	16,277	
A1400	1 $\frac{5}{8}$	14	1,216	0.056	–	0.133	–	0.067	7,058	
B1400	1 $\frac{3}{16}$	14	425	0.110	–	0.133	258	0.067	4,000	
<b>30 in. beam or column</b>										
A1200	1 $\frac{5}{8}$	12	1,414	0.089	–	0.167	–	0.083	9,419	
B1200	1 $\frac{3}{16}$	12	420	0.164	–	0.167	266	0.083	4,465	
C1200	1 $\frac{3}{8}$	12	1,034	0.104	–	0.167	1,040	0.083	8,060	
D1200	1	12	0.615	0.129	–	0.167	389	0.083	6,650	
E1200	2 $\frac{7}{16}$	12	2,660	0.063	–	0.167	–	0.083	12,640	
H1200	3 $\frac{1}{4}$	12	4,234	0.046	–	0.167	–	0.083	15,698	
A1400	1 $\frac{5}{8}$	14	974	0.088	–	0.167	–	0.083	6,753	
B1400	1 $\frac{3}{16}$	14	340	0.172	–	0.167	165	0.083	3,420	

When no numbers are shown, use the maximum uniform load.  
Deflections are given in inches; loads in lb

Double channel										
Cat. no.	Depth (in.)	Ga.	Maximum Uniform			$\frac{1}{160}$ Span		$\frac{1}{500}$ Span		Col. load
			Load	Defl.	Load	Defl.	Load	Defl.		
<b>12 in. beam or column</b>										
A1202	3 $\frac{1}{4}$	12	–	0.008	–	0.067	–	0.033	21,177	
B1202	1 $\frac{5}{8}$	12	3,016	0.016	–	0.067	–	0.033	14,110	
C1202	2 $\frac{3}{4}$	12	–	0.010	–	0.067	–	0.033	18,990	
D1202	2	12	–	0.012	–	0.067	–	0.033	18,312	
E1202	4 $\frac{7}{8}$	12	–	0.005	–	0.067	–	0.033	27,623	
H1202	6 $\frac{1}{2}$	12	–	0.004	–	0.067	–	0.033	34,210	
A1402	3 $\frac{1}{4}$	14	–	0.008	–	0.067	–	0.033	15,250	
B1402	1 $\frac{5}{8}$	14	2,300	0.016	–	0.067	–	0.033	10,390	
<b>18 in. beam or column</b>										
A1202	3 $\frac{1}{4}$	12	–	0.018	–	0.100	–	0.050	20,609	
B1202	1 $\frac{5}{8}$	12	2,011	0.036	–	0.100	–	0.050	13,440	
C1202	2 $\frac{3}{4}$	12	4,811	0.021	–	0.100	–	0.050	18,470	
D1202	2	12	–	0.028	–	0.100	–	0.050	17,942	
E1202	4 $\frac{7}{8}$	12	–	0.013	–	0.100	–	0.050	16,926	
H1202	6 $\frac{1}{2}$	12	–	0.009	–	0.100	–	0.050	33,390	
A1402	3 $\frac{1}{4}$	14	–	0.018	–	0.100	–	0.050	14,867	
B1402	1 $\frac{5}{8}$	14	1,534	0.036	–	0.100	–	0.050	9,910	
<b>24 in. beam or column</b>										
A1202	3 $\frac{1}{4}$	12	4,858	0.031	–	0.133	–	0.067	19,974	
B1202	1 $\frac{5}{8}$	12	1,509	0.064	–	0.133	–	0.067	12,670	
C1202	2 $\frac{3}{4}$	12	3,609	0.038	–	0.133	–	0.067	17,890	
D1202	2	12	2,680	0.042	–	0.133	–	0.067	17,160	
E1202	4 $\frac{7}{8}$	12	–	0.021	–	0.133	–	0.067	26,143	
H1202	6 $\frac{1}{2}$	12	–	0.016	–	0.133	–	0.067	32,435	
A1402	3 $\frac{1}{4}$	14	3,425	0.033	–	0.133	–	0.067	14,426	
B1402	1 $\frac{5}{8}$	14	1,150	0.064	–	0.133	–	0.067	9,350	
<b>30 in. beam or column</b>										
A1202	3 $\frac{1}{4}$	12	3,886	0.049	–	0.167	–	0.083	19,261	
B1202	1 $\frac{5}{8}$	12	1,206	0.100	–	0.167	–	0.083	11,803	
C1202	2 $\frac{3}{4}$	12	2,886	0.059	–	0.167	–	0.083	17,230	
D1202	2	12	2,128	0.084	–	0.167	–	0.083	16,480	
E1202	4 $\frac{7}{8}$	12	7,806	0.034	–	0.167	–	0.083	25,259	
H1202	6 $\frac{1}{2}$	12	–	0.025	–	0.167	–	0.083	31,395	
A1402	3 $\frac{1}{4}$	14	2,740	0.050	–	0.167	–	0.083	13,937	
B1402	1 $\frac{5}{8}$	14	920	0.100	–	0.167	–	0.083	8,730	

## Engineering data and specifications

### Design data – metal framing channel

Table 3 (cont'd)

Single channel										
Cat. no.	Depth (in.)	Ga.	Maximum uniform			$\frac{1}{800}$ Span		$\frac{1}{500}$ Span		Col. load
			Load	Defl.	Load	Defl.	Load	Defl.		
<b>36 in. beam or column</b>										
A1200	1 $\frac{5}{8}$	12	1,178	0.129	–	0.200	917	0.100	8,962	
B1200	1 $\frac{3}{16}$	12	350	0.236	–	0.200	148	0.100	3,498	
C1200	1 $\frac{3}{8}$	12	861	0.149	–	0.200	578	0.100	7,525	
D1200	1	12	513	0.198	–	0.200	217	0.100	4,335	
E1200	2 $\frac{7}{16}$	12	2,216	0.088	–	0.200	–	0.100	12,160	
H1200	3 $\frac{3}{4}$	12	3,528	0.068	–	0.200	–	0.100	15,132	
A1400	1 $\frac{5}{8}$	14	811	0.126	–	0.200	640	0.100	6,416	
B1400	1 $\frac{3}{16}$	14	284	0.248	–	0.200	115	0.100	2,755	
<b>42 in. beam or column</b>										
A1200	1 $\frac{5}{8}$	12	1,010	0.175	–	0.233	674	0.117	8,466	
B1200	1 $\frac{3}{16}$	12	300	0.323	217	0.233	109	0.117	2,579	
C1200	1 $\frac{3}{8}$	12	738	0.203	–	0.233	425	0.117	6,945	
D1200	1	12	440	0.264	319	0.233	160	0.117	3,280	
E1200	2 $\frac{7}{16}$	12	1,900	0.120	–	0.233	–	0.117	11,698	
H1200	3 $\frac{3}{4}$	12	3,024	0.091	–	0.233	–	0.117	14,514	
A1400	1 $\frac{5}{8}$	14	695	0.160	–	0.233	470	0.117	6,051	
B1400	1 $\frac{3}{16}$	14	243	0.336	168	0.233	84	0.117	2,060	
<b>48 in. beam or column</b>										
A1200	1 $\frac{5}{8}$	12	884	0.228	–	0.267	516	0.133	7,943	
B1200	1 $\frac{3}{16}$	12	263	0.420	167	0.267	83	0.133	1,981	
C1200	1 $\frac{3}{8}$	12	646	0.265	–	0.267	325	0.133	6,325	
D1200	1	12	384	0.352	244	0.267	122	0.133	2,439	
E1200	2 $\frac{7}{16}$	12	1,663	0.156	–	0.267	–	0.133	11,092	
H1200	3 $\frac{3}{4}$	12	2,646	0.120	–	0.267	–	0.133	13,850	
A1400	1 $\frac{5}{8}$	14	609	0.120	–	0.267	360	0.133	5,658	
B1400	1 $\frac{3}{16}$	14	213	0.440	129	0.267	64	0.133	1,580	
<b>54 in. beam or column</b>										
A1200	1 $\frac{5}{8}$	12	785	0.289	–	0.300	408	0.150	7,369	
B1200	1 $\frac{3}{16}$	12	234	0.533	132	0.300	66	0.150	1,555	
C1200	1 $\frac{3}{8}$	12	574	0.335	–	0.300	257	0.150	5,650	
D1200	1	12	341	0.466	193	0.300	96	0.150	2,012	
E1200	2 $\frac{7}{16}$	12	1,478	0.198	–	0.300	1,123	0.150	10,505	
H1200	3 $\frac{3}{4}$	12	2,351	0.151	–	0.300	–	0.150	13,150	
A1400	1 $\frac{5}{8}$	14	541	0.286	–	0.300	284	0.150	5,241	
B1400	1 $\frac{3}{16}$	14	189	0.556	102	0.300	51	0.150	1,250	

When no numbers are shown, use the maximum uniform load.  
Deflections are given in inches; loads in lb

Double channel										
Cat. no.	Depth (in.)	Ga.	Maximum uniform			$\frac{1}{800}$ Span		$\frac{1}{500}$ Span		Col. load
			Load	Defl.	Load	Defl.	Load	Defl.		
<b>36 in. beam or column</b>										
A1202	3 $\frac{3}{4}$	12	3,239	0.071	–	0.200	–	0.100	18,470	
B1202	1 $\frac{5}{8}$	12	1,005	0.144	–	0.200	702	0.100	10,840	
C1202	2 $\frac{3}{4}$	12	2,400	0.085	–	0.200	–	0.100	16,500	
D1202	2	12	1,428	0.114	–	0.200	1,248	0.100	15,057	
E1202	4 $\frac{7}{8}$	12	6,505	0.048	–	0.200	–	0.100	24,316	
H1202	6 $\frac{1}{2}$	12	–	0.036	–	0.200	–	0.100	30,265	
A1402	3 $\frac{3}{4}$	14	2,284	0.071	–	0.200	–	0.100	13,416	
B1402	1 $\frac{5}{8}$	14	766	0.144	–	0.200	535	0.100	8,050	
<b>42 in. beam or column</b>										
A1202	3 $\frac{3}{4}$	12	2,776	0.098	–	0.233	–	0.117	17,635	
B1202	1 $\frac{5}{8}$	12	863	0.195	–	0.233	516	0.117	9,790	
C1202	2 $\frac{3}{4}$	12	2,063	0.115	–	0.233	–	0.117	15,730	
D1202	2	12	1,224	0.166	–	0.233	1,069	0.117	13,042	
E1202	4 $\frac{7}{8}$	12	5,576	0.065	–	0.233	–	0.117	23,272	
H1202	6 $\frac{1}{2}$	12	–	0.049	–	0.233	–	0.117	29,025	
A1402	3 $\frac{3}{4}$	14	1,958	0.225	–	0.233	–	0.117	12,832	
B1402	1 $\frac{5}{8}$	14	658	0.195	–	0.233	393	0.117	7,300	
<b>48 in. beam or column</b>										
A1202	3 $\frac{3}{4}$	12	2,429	0.128	–	0.267	–	0.133	16,730	
B1202	1 $\frac{5}{8}$	12	754	0.255	–	0.267	395	0.133	8,640	
C1202	2 $\frac{3}{4}$	12	1,804	0.151	–	0.267	–	0.133	14,890	
D1202	2	12	1,071	0.203	–	0.267	702	0.133	11,387	
E1202	4 $\frac{7}{8}$	12	4,879	0.085	–	0.267	–	0.133	22,170	
H1202	6 $\frac{1}{2}$	12	–	0.064	–	0.267	–	0.133	27,700	
A1402	3 $\frac{3}{4}$	14	1,713	0.128	–	0.267	–	0.133	12,223	
B1402	1 $\frac{5}{8}$	14	575	0.255	–	0.267	301	0.133	6,480	
<b>54 in. beam or column</b>										
A1202	3 $\frac{3}{4}$	12	2,159	0.161	–	0.300	–	0.150	15,763	
B1202	1 $\frac{5}{8}$	12	670	0.323	–	0.300	312	0.150	7,405	
C1202	2 $\frac{3}{4}$	12	1,604	0.190	–	0.300	1,263	0.150	13,990	
D1202	2	12	952	0.266	–	0.300	624	0.150	10,391	
E1202	4 $\frac{7}{8}$	12	4,338	0.108	–	0.300	–	0.150	20,980	
H1202	6 $\frac{1}{2}$	12	7,149	0.081	–	0.300	–	0.150	16,280	
A1402	3 $\frac{3}{4}$	14	1,523	0.161	–	0.300	–	0.150	11,566	
B1402	1 $\frac{5}{8}$	14	511	0.323	–	0.300	238	0.150	5,580	

## Engineering data and specifications

### Design data – metal framing channel

Table 3 (cont'd)

Single channel										
Cat. no.	Depth (in.)	Ga.	Maximum uniform			$\frac{1}{800}$ Span		$\frac{1}{500}$ Span		Col. load
			Load	Defl.	Load	Defl.	Load	Defl.		
<b>60 in. beam or column</b>										
A1200	1 $\frac{5}{8}$	12	706	0.358	–	0.333	330	0.167	6,762	
B1200	1 $\frac{3}{16}$	12	210	0.658	107	0.333	53	0.167	–	
C1200	1 $\frac{3}{8}$	12	516	0.414	–	0.333	208	0.167	4,920	
D1200	1	12	308	0.550	157	0.333	78	0.167	1,561	
E1200	2 $\frac{7}{16}$	12	1,330	0.244	–	0.333	909	0.167	9,874	
H1200	3 $\frac{3}{4}$	12	2,116	0.186	–	0.333	–	0.167	12,406	
A1400	1 $\frac{5}{8}$	14	486	0.353	–	0.333	231	0.167	4,792	
B1400	1 $\frac{3}{16}$	14	170	0.687	82	0.333	41	0.167	–	
<b>66 in. beam or column</b>										
200	1 $\frac{5}{8}$	12	643	0.432	–	0.367	273	0.183	6,127	
B1200	1 $\frac{3}{16}$	12	191	0.795	88	0.367	44	0.183	–	
C1200	1 $\frac{3}{8}$	12	470	0.501	344	0.367	172	0.183	4,145	
D1200	1	12	280	0.675	129	0.367	65	0.183	1,280	
E1200	2 $\frac{7}{16}$	12	1,210	0.295	–	0.367	753	0.183	9,211	
H1200	3 $\frac{3}{4}$	12	1,924	0.226	–	0.367	–	0.183	11,616	
A1400	1 $\frac{5}{8}$	14	443	0.426	–	0.367	190	0.183	4,311	
B1400	1 $\frac{3}{16}$	14	155	0.831	68	0.367	35	0.183	–	
<b>72 in. beam or column</b>										
A1200	1 $\frac{5}{8}$	12	589	0.514	459	0.400	299	0.200	5,436	
B1200	1 $\frac{3}{16}$	12	175	0.946	74	0.400	37	0.200	–	
C1200	1 $\frac{3}{8}$	12	430	0.595	289	0.400	144	0.200	3,485	
D1200	1	12	256	0.792	108	0.400	54	0.200	1,084	
E1200	2 $\frac{7}{16}$	12	1,108	0.351	–	0.400	632	0.200	8,509	
H1200	3 $\frac{3}{4}$	12	1,839	0.269	–	0.400	1,313	0.200	10,782	
A1400	1 $\frac{5}{8}$	14	405	0.506	320	0.400	160	0.200	3,809	
B1400	1 $\frac{3}{16}$	14	141	0.989	57	0.400	29	0.200	–	
<b>84 in. beam or column</b>										
A1200	1 $\frac{5}{8}$	12	505	0.700	337	0.467	168	0.233	4,061	
B1200	1 $\frac{3}{16}$	12	–	–	54	0.467	27	0.233	–	
C1200	1 $\frac{3}{8}$	12	369	0.811	212	0.467	106	0.233	2,565	
D1200	1	12	220	1.079	92	0.467	58	0.233	796	
E1200	2 $\frac{7}{16}$	12	950	0.479	–	0.467	464	0.233	6,991	
H1200	3 $\frac{3}{4}$	12	1,513	0.366	–	0.467	965	0.233	8,988	
A1400	1 $\frac{5}{8}$	14	348	0.691	235	0.467	118	0.233	2,827	
B1400	1 $\frac{3}{16}$	14	–	–	42	0.467	21	0.233	–	

When no numbers are shown, use the maximum uniform load.  
Deflections are given in inches; loads in lb

Double channel										
Cat. no.	Depth (in.)	Ga.	Maximum uniform			$\frac{1}{800}$ Span		$\frac{1}{500}$ Span		Col. load
			Load	Defl.	Load	Defl.	Load	Defl.		
<b>60 in. beam or column</b>										
A1202	3 $\frac{3}{4}$	12	1,944	0.199	–	0.333	–	0.167	14,738	
B1202	1 $\frac{5}{8}$	12	604	0.398	–	0.333	253	0.167	6,100	
C1202	2 $\frac{3}{4}$	12	1,444	0.235	–	0.333	1,023	0.167	13,050	
D1202	2	12	257	0.318	–	0.333	449	0.167	7,531	
E1202	4 $\frac{7}{8}$	12	3,904	0.133	–	0.333	–	0.167	19,734	
H1202	6 $\frac{1}{2}$	12	6,434	0.100	–	0.333	–	0.167	24,810	
A1402	3 $\frac{3}{4}$	14	1,370	0.199	–	0.333	–	0.167	10,878	
B1402	1 $\frac{5}{8}$	14	460	0.399	–	0.333	193	0.167	4,640	
<b>66 in. beam or column</b>										
A1202	3 $\frac{3}{4}$	12	1,766	0.240	–	0.367	1,347	0.183	13,646	
B1202	1 $\frac{5}{8}$	12	549	0.481	418	0.367	209	0.183	5,055	
C1202	2 $\frac{3}{4}$	12	1,313	0.285	–	0.367	846	0.183	12,030	
D1202	2	12	779	0.377	593	0.367	360	0.183	6,581	
E1202	4 $\frac{7}{8}$	12	3,549	0.180	–	0.367	–	0.183	18,415	
H1202	6 $\frac{1}{2}$	12	5,849	0.120	–	0.367	–	0.183	23,230	
A1402	3 $\frac{3}{4}$	14	1,245	0.241	–	0.367	949	0.183	10,133	
B1402	1 $\frac{5}{8}$	14	419	0.483	318	0.367	159	0.183	3,840	
<b>72 in. beam or column</b>										
A1202	3 $\frac{3}{4}$	12	1,620	0.286	v	0.400	1,132	0.200	12,500	
B1202	1 $\frac{5}{8}$	12	503	0.574	351	0.400	176	0.200	4,230	
C1202	2 $\frac{3}{4}$	12	1,203	0.339	–	0.400	710	0.200	10,980	
D1202	2	12	714	0.457	468	0.400	312	0.200	5,230	
E1202	4 $\frac{7}{8}$	12	3,253	0.191	–	0.400	–	0.200	17,023	
H1202	6 $\frac{1}{2}$	12	5,361	0.143	–	0.400	–	0.200	21,560	
A1402	3 $\frac{3}{4}$	14	1,141	0.286	–	0.400	798	0.200	9,340	
B1402	1 $\frac{5}{8}$	14	384	0.574	267	0.400	134	0.200	3,220	
<b>84 in. beam or column</b>										
A1202	3 $\frac{3}{4}$	12	1,388	0.390	–	0.467	832	0.233	9,992	
B1202	1 $\frac{5}{8}$	12	431	0.780	258	0.467	129	0.233	3,100	
C1202	2 $\frac{3}{4}$	12	1,031	0.461	–	0.467	522	0.233	8,670	
D1202	2	12	612	0.623	344	0.467	229	0.233	3,842	
E1202	4 $\frac{7}{8}$	12	2,788	0.260	–	0.467	–	0.233	13,993	
H1202	6 $\frac{1}{2}$	12	4,595	0.195	–	0.467	–	0.233	17,975	
A1402	3 $\frac{3}{4}$	14	979	0.390	–	0.467	586	0.233	7,682	
B1402	1 $\frac{5}{8}$	14	329	0.781	197	0.467	98	0.233	2,370	

## Engineering data and specifications

### Design data – metal framing channel

Table 3 (cont'd)

Single channel										
Cat. no.	Depth (in.)	Ga.	Maximum uniform			$\frac{1}{800}$ Span		$\frac{1}{800}$ Span		Col. load
			Load	Defl.	Load	Defl.	Load	Defl.		
<b>96 in. beam or column</b>										
A1200	1 $\frac{5}{8}$	12	441	0.914	258	0.533	129	0.267	3,108	
B1200	1 $\frac{3}{16}$	12	–	–	42	0.533	21	0.267	–	
C1200	1 $\frac{3}{8}$	12	323	1.059	163	0.533	81	0.267	1,960	
D1200	1	12	192	1.400	998	0.533	49	0.267	–	
E1200	2 $\frac{7}{16}$	12	831	0.730	–	0.533	355	0.267	5,423	
H1200	3 $\frac{3}{4}$	12	1,323	0.478	–	0.533	739	0.267	7,059	
A1400	1 $\frac{5}{8}$	14	304	0.903	180	0.533	90	0.267	2,615	
B1400	1 $\frac{3}{16}$	14	–	–	32	0.533	16	0.267	–	
<b>108 in. beam or column</b>										
A1200	1 $\frac{5}{8}$	12	393	1.156	204	0.600	102	0.300	2,456	
B1200	1 $\frac{3}{16}$	12	–	–	33	0.600	16	0.300	–	
C1200	1 $\frac{3}{8}$	12	288	1.350	128	0.600	64	0.300	–	
D1200	1	12	171	1.783	76	0.600	38	0.300	–	
E1200	2 $\frac{7}{16}$	12	739	0.790	561	0.600	281	0.300	4,291	
H1200	3 $\frac{3}{4}$	12	1,176	0.605	–	0.600	584	0.300	5,579	
A1400	1 $\frac{5}{8}$	14	270	1.141	142	0.600	71	0.300	1,708	
B1400	1 $\frac{3}{16}$	14	–	–	25	0.600	13	0.300	–	
<b>120 in. beam or column</b>										
A1200	1 $\frac{5}{8}$	12	354	1.425	165	0.667	83	0.333	–	
B1200	1 $\frac{3}{16}$	12	–	–	27	0.667	13	0.333	–	
C1200	1 $\frac{3}{8}$	12	259	1.663	104	0.667	52	0.333	–	
D1200	1	12	154	2.202	62	0.667	31	0.333	–	
E1200	2 $\frac{7}{16}$	12	665	0.976	455	0.667	227	0.333	3,478	
H1200	3 $\frac{3}{4}$	12	1,059	0.746	–	0.667	473	0.333	4,521	
A1400	1 $\frac{5}{8}$	14	244	1.413	114	0.667	57	0.333	–	
B1400	1 $\frac{3}{16}$	14	–	–	21	0.667	10	0.333	–	
<b>144 in. beam or column</b>										
A1200	1 $\frac{5}{8}$	12	–	–	115	0.800	57	0.400	–	
–	–	–	–	–	–	–	–	–	–	
C1200	1 $\frac{3}{8}$	12	–	–	72	0.800	36	0.400	–	
E1200	2 $\frac{7}{16}$	12	554	1.400	315	0.800	158	0.400	–	
H1200	3 $\frac{3}{4}$	12	883	1.075	657	0.800	328	0.400	–	
A1400	1 $\frac{5}{8}$	14	–	–	80	0.800	40	0.400	–	

When no numbers are shown, use the maximum uniform load.  
Deflections are given in inches; loads in lb

Double channel										
Cat. no.	Depth (in.)	Ga.	Maximum uniform			$\frac{1}{800}$ Span		$\frac{1}{800}$ Span		Col. load
			Load	Defl.	Load	Defl.	Load	Defl.		
<b>96 in. beam or column</b>										
A1202	3 $\frac{3}{4}$	12	1,215	0.509	–	0.533	637	0.267	7,675	
B1202	1 $\frac{5}{8}$	12	378	1.019	197	0.533	99	0.267	–	
C1202	2 $\frac{3}{4}$	12	903	0.603	–	0.533	400	0.267	6,640	
D1202	2	12	535	0.813	263	0.533	176	0.267	2,942	
E1202	4 $\frac{7}{8}$	12	2,440	0.340	–	0.533	1,917	0.267	10,875	
H1202	6 $\frac{1}{2}$	12	4,021	0.255	–	0.533	–	0.267	14,120	
A1402	3 $\frac{3}{4}$	14	856	0.509	–	0.533	449	0.267	5,951	
B1402	1 $\frac{5}{8}$	14	288	1.020	150	0.533	75	0.267	–	
<b>108 in. beam or column</b>										
A1202	3 $\frac{3}{4}$	12	1,080	0.644	–	0.600	503	0.300	6,071	
B1202	1 $\frac{5}{8}$	12	355	1.290	156	0.600	78	0.300	–	
C1202	2 $\frac{3}{4}$	12	801	0.763	632	0.600	316	0.300	5,250	
D1202	2	12	476	1.029	208	0.600	139	0.300	2,324	
E1202	4 $\frac{7}{8}$	12	2,169	0.430	–	0.600	1,515	0.300	8,599	
H1202	6 $\frac{1}{2}$	12	3,574	0.323	–	0.600	–	0.300	11,160	
A1402	3 $\frac{3}{4}$	14	761	0.644	–	0.600	355	0.300	4,702	
B1402	1 $\frac{5}{8}$	14	255	1.290	119	0.600	59	0.300	–	
<b>120 in. beam or column</b>										
A1202	3 $\frac{3}{4}$	12	971	0.795	–	0.667	408	0.333	–	
B1202	1 $\frac{5}{8}$	12	301	1.588	126	0.667	63	0.333	–	
C1202	2 $\frac{3}{4}$	12	721	0.941	512	0.667	256	0.333	4,250	
D1202	2	12	428	1.271	168	0.667	112	0.333	1,883	
E1202	4 $\frac{7}{8}$	12	1,951	0.531	–	0.667	1,227	0.333	6,946	
H1202	6 $\frac{1}{2}$	12	3,216	0.398	–	0.667	–	0.333	9,040	
A1402	3 $\frac{3}{4}$	14	685	0.796	–	0.667	287	0.333	3,805	
B1402	1 $\frac{5}{8}$	14	230	1.600	96	0.667	48	0.333	–	
<b>144 in. beam or column</b>										
A1202	3 $\frac{3}{4}$	12	810	1.145	566	0.800	283	0.400	–	
B1202	1 $\frac{5}{8}$	12	–	–	88	0.800	44	0.400	–	
C1202	2 $\frac{3}{4}$	12	601	1.350	355	0.800	178	0.400	–	
E1202	4 $\frac{7}{8}$	12	1,626	0.764	–	0.800	852	0.400	–	
H1202	6 $\frac{1}{2}$	12	2,680	0.573	–	0.800	1,873	0.400	–	
A1402	3 $\frac{3}{4}$	14	571	1.146	399	0.800	199	0.400	–	
B1402	1 $\frac{5}{8}$	14	–	–	67	0.800	33	0.400	–	





## Engineering data and specifications

### Design data – metal framing channel

Table 4

#### Safe bearing loads for 1½ in. channel and combinations.

Safety factor of 2½

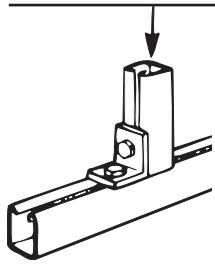
	Section	Recommended load in lb
	A1200	5,000
	A1400	3,500
	B1200	6,000
	B1400	3,400
	C1200	5,000
	E1200	5,000
	H1200	4,000

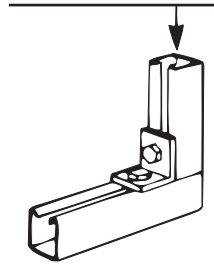
	Section	Recommended load in lb
	A1200	3,500
	A1400	2,500
	B1200	4,000
	B1400	2,600
	C1200	3,500
	E1200	3,500
	H1200	2,000

	Section	Recommended load in lb
	A1200	8,000
	A1400	5,500
	B1200	9,000
	B1400	4,800
	C1200	8,000
	E1200	8,000
	H1200	5,500

Table 5



#### Design load table for typical channel connections.

Safety factor of 2½ based on ultimate strength of the connection.

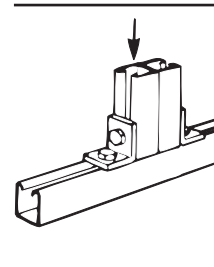
Load diagrams indicate up to three design loads, for 12 gauge and 14 gauge channel applications.

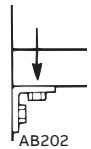
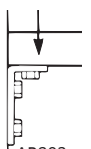
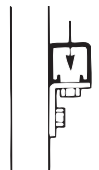
#### 90° Fittings (when used in position shown)

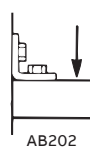
	Cat. no.	Section	Recommended Section load in lb
	AB202	A1200	1,500
		A1400	1,000
	AB203	A1200	2,000
		A1400	1,500
	AB201		700
		AB203	700

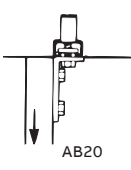
	Cat. no.	Section	Recommended Section load in lb
	AB202	A1200	1,000
		A1400	650
	AB213 AB214	A1200	3,000
		A1400	2,000
	AB20		1,500

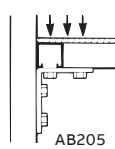
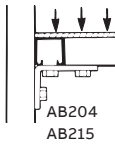
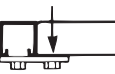
	Cat. no.	Section	Recommended Section load in lb
	AB205 AB216	A1200	2,000
		A1400	2,000
	AB204 AB215	A1200	1,500
		A1400	1,000
<b>Flat plate fittings</b>			
	AB206	A1200	1,000
		A1400	800

# Engineering data and specifications

## Design applications

### Cantilever beams

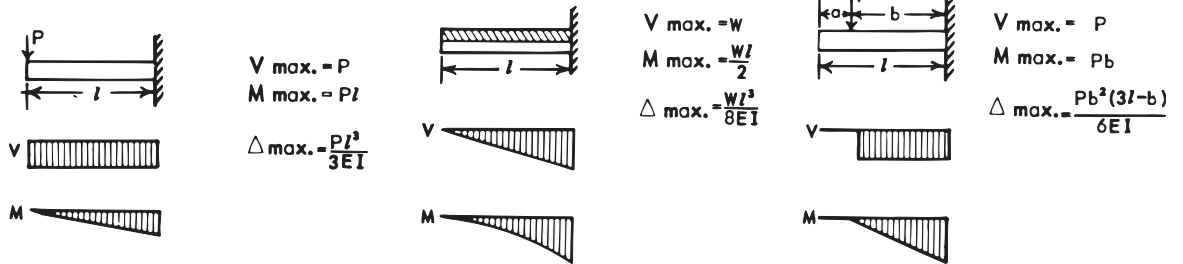

### Simple beams

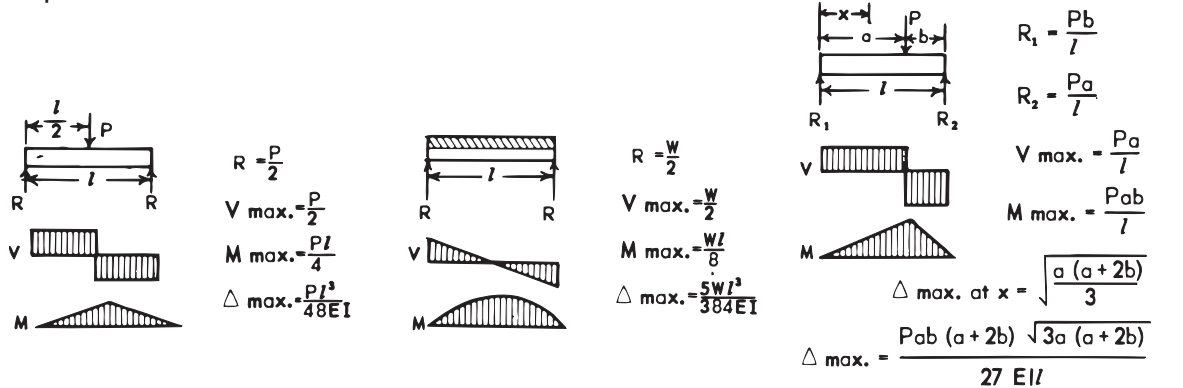

### Beams fixed on one end, supported at the other end

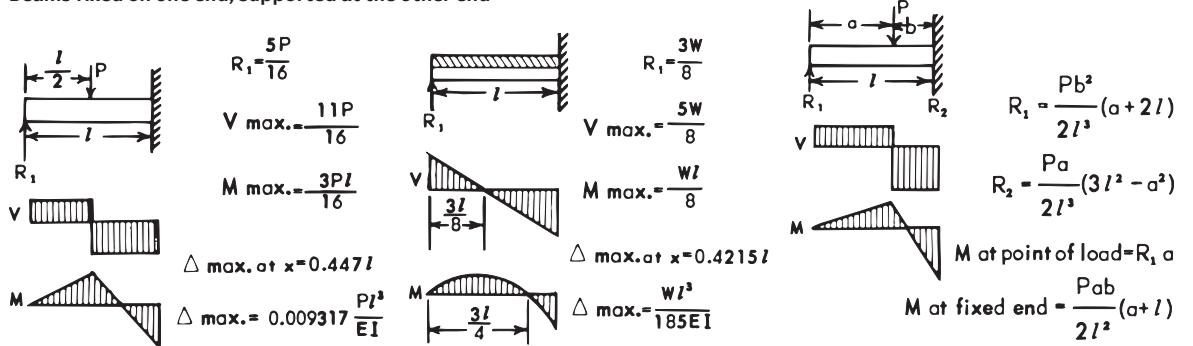

### Beams fixed at both ends

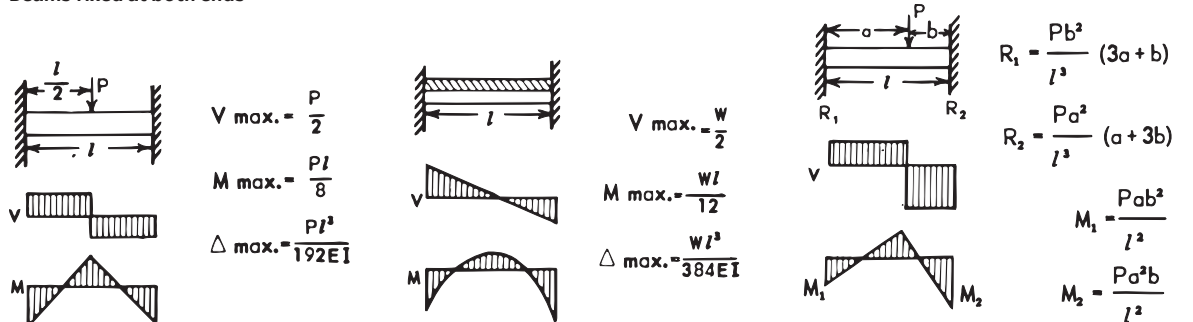

R - Reaction  
 M - Moment  
 P - Concentrated load

W - Total uniform load  
 V - Shear

$\Delta$  - Deflection  
 E - Modulus of Elasticity  
 I - Moment of Inertia

## Engineering data and specifications









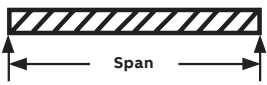

### Design applications

Table 6

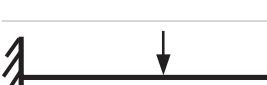
**Conversion factors for beams with various static loading conditions**

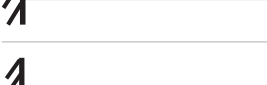
Load tables on pages A68 through A72 for A, B, C, E, and H series channel are for single span beams supported at the ends. These can be used in the majority of cases. There are

times when it is necessary to know what happens with other loading and support conditions. Some common arrangements are shown in Table 6. Simply multiply the loads from the design load tables times the factors given in Table 6.

	Load and support condition	Load factor	Deflection factor
	1. Simple beam – Uniform load	1.00	1.00
	2. Simple beam – Concentrated load at center	0.50	1.25
	3. Simple beam – Two equal concentrated loads at 1/4 points	1.00	1.10
	4. Beam fixed at both ends – Uniform load	1.50	0.30
	5. Beam fixed at both ends – Concentrated load at center	1.00	0.40
	6. Cantilever beam – Uniform load	0.25	2.40
	7. Cantilever beam – Concentrated load at end	0.12	3.20
	8. Continuous beam – Two equal spans – Uniform load on one span	1.30	0.92
	9. Continuous beam – Two equal spans – Uniform load on both ends	1.00	0.42
	10. Continuous beam – Two equal spans – Concentrated load at center of one span	0.62	0.71
	11. Continuous beam – Two Equal Spans – Concentrated load at center of both spans	0.67	0.48

## Engineering data and specifications

### Design applications

#### Example I

**Problem:**

Determine the load and deflection of an A1200 beam continuous over one support and loaded uniformly on one span.

**Solution:**

- A. From load table 3 for A1200 the load for a 5 ft. 0 in. span is 706 lb and deflection is 0.358 in.
- B. Multiply by factors from Table 6.  
 Load = 706 lb x 1.30 = 917.8 lb  
 Deflection = 0.358 in. x 0.92 = 0.329 in.



#### Example II

**Problem:**

Determine load and deflection of an E1200 cantilever beam with a concentrated load on the end.

**Solution:**

- A. From load table 3 for E1200 the load for a 3 ft. 0 in. span is 2,216 lb and deflection is 0.088 in.
- B. Multiply by factors from Table 6.  
 Load = 2,216 lb x 0.12 = 265.9 lb  
 Deflection = 0.088 in. x 3.20 = 0.282 in.

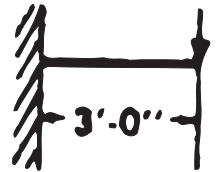

#### Column loading

The load bearing capacity of column or compression members is a function of the inherent configurational strength, the unbraced length and design of the end connections.

Values of axial column loading given in Table 3 were calculated using a rotationally free and translation fixed correction at each end (see Illustration I). This gives an end condition constant (K) of 1.

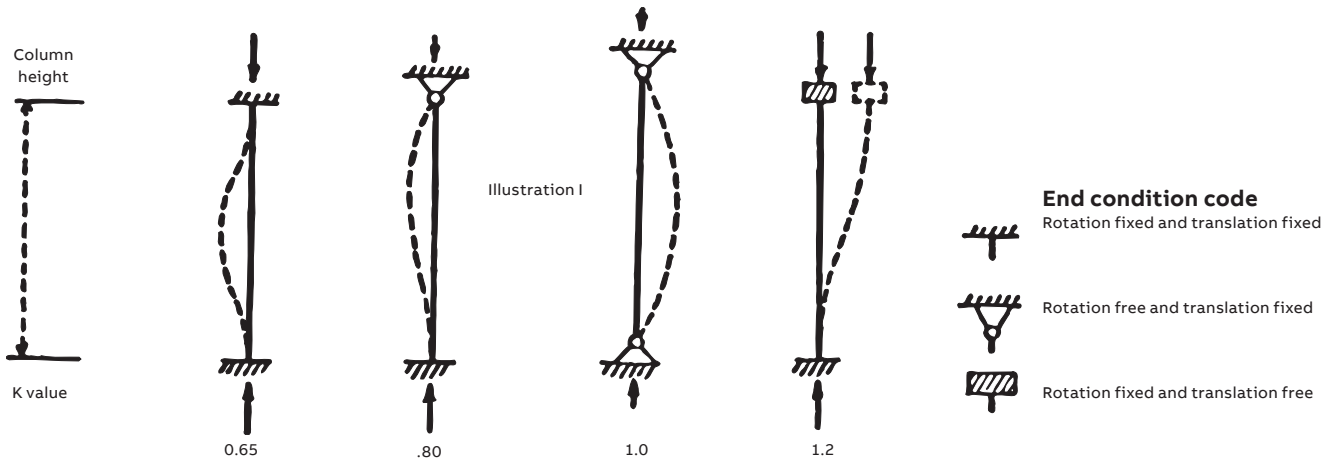

If other end conditions are used, axial loading should be calculated using procedures in the AISI specification for the design of cold formed steel structural members (SG671) and the engineering values for Superstrut channel given in Table 1.

Table 7

Load carrying capacities of hot-rolled steel rod

Nominal rod dia. (in.)	Root area thread (in.)	Design load lb for serv. temperature	
		343 °C (650 °F)	399 °C (750 °F)
3/8	0.068	610	540
1/2	0.126	1,130	1,010
5/8	0.202	1,810	1,610
3/4	0.302	2,710	2,420
7/8	0.419	3,770	3,360

Safety factor of 5.

Table 8

Rod size determined by pipe size for fire protection

Pipe size (in.)	Rod size (in.)
3/4 to 2	3/8
2 1/2 to 3 1/2	1/2
4 to 5	5/8
6	3/4
8 to 12	7/8

## Engineering data and specifications

### Design applications

Table 9

Maximum spacing between pipe supports

Steel pipe																		
Nom. pipe size (in.)	½	¾	1	1½	2	2½	3	3½	4	5	6	8	10	12	14	16	18	20
Max. spacing (ft.)	5	6	7	9	10	11	12	13	14	16	17	19	22	23	25	27	28	30
Copper pipe																		
Nom. pipe size (in.)	½	¾	1	1¼	1½	2	2½	3	3½	4								
Max. spacing (ft.)	5	6	6	7	8	9	10	10	11	12								

Table 10

Minimum spacing (inches) between centers of standard pipe when using Superstrut #702 pipe straps

Nom. pipe size (in.)	½	¾	1	1¼	1½	2	2½	3	3½	4	5	6	8
½	1 <sup>3</sup> / <sub>16</sub>	–	–	–	–	–	–	–	–	–	–	–	–
¾	1 <sup>5</sup> / <sub>16</sub>	1 <sup>7</sup> / <sub>16</sub>	–	–	–	–	–	–	–	–	–	–	–
1	1½	1 <sup>5</sup> / <sub>8</sub>	1¾	–	–	–	–	–	–	–	–	–	–
1¼	1¾	1 <sup>7</sup> / <sub>8</sub>	2	2¼	–	–	–	–	–	–	–	–	–
1½	1 <sup>15</sup> / <sub>16</sub>	2 <sup>1</sup> / <sub>16</sub>	2 <sup>3</sup> / <sub>16</sub>	2 <sup>7</sup> / <sub>16</sub>	2 <sup>9</sup> / <sub>16</sub>	–	–	–	–	–	–	–	–
2	2 <sup>3</sup> / <sub>16</sub>	2 <sup>5</sup> / <sub>16</sub>	2½	2¾	2 <sup>7</sup> / <sub>8</sub>	3 <sup>1</sup> / <sub>8</sub>	–	–	–	–	–	–	–
2½	2 <sup>7</sup> / <sub>16</sub>	2 <sup>9</sup> / <sub>16</sub>	2¾	3	3 <sup>1</sup> / <sub>8</sub>	3 <sup>3</sup> / <sub>8</sub>	3 <sup>5</sup> / <sub>8</sub>	–	–	–	–	–	–
3	2 <sup>13</sup> / <sub>16</sub>	2 <sup>15</sup> / <sub>16</sub>	3 <sup>1</sup> / <sub>16</sub>	3 <sup>5</sup> / <sub>16</sub>	3 <sup>7</sup> / <sub>16</sub>	3¾	4	4 <sup>5</sup> / <sub>16</sub>	–	–	–	–	–
3½	3 <sup>1</sup> / <sub>8</sub>	3¼	3 <sup>3</sup> / <sub>8</sub>	3 <sup>5</sup> / <sub>8</sub>	3¾	4 <sup>1</sup> / <sub>16</sub>	4 <sup>5</sup> / <sub>16</sub>	4 <sup>9</sup> / <sub>16</sub>	4 <sup>15</sup> / <sub>16</sub>	–	–	–	–
4	3 <sup>7</sup> / <sub>16</sub>	3 <sup>9</sup> / <sub>16</sub>	3 <sup>15</sup> / <sub>16</sub>	4 <sup>1</sup> / <sub>16</sub>	4 <sup>3</sup> / <sub>8</sub>	4 <sup>5</sup> / <sub>8</sub>	4 <sup>15</sup> / <sub>16</sub>	5¼	5 <sup>9</sup> / <sub>16</sub>	–	–	–	–
6	4¾	4 <sup>7</sup> / <sub>8</sub>	5	5¼	5 <sup>3</sup> / <sub>8</sub>	5 <sup>5</sup> / <sub>8</sub>	5 <sup>7</sup> / <sub>8</sub>	6 <sup>3</sup> / <sub>16</sub>	6½	6 <sup>13</sup> / <sub>16</sub>	7 <sup>7</sup> / <sub>16</sub>	8 <sup>1</sup> / <sub>8</sub>	–
8	5 <sup>7</sup> / <sub>16</sub>	6	6 <sup>1</sup> / <sub>8</sub>	6 <sup>3</sup> / <sub>8</sub>	6½	6¾	7	7 <sup>5</sup> / <sub>16</sub>	7 <sup>7</sup> / <sub>8</sub>	8	8 <sup>9</sup> / <sub>16</sub>	9¼	10 <sup>3</sup> / <sub>8</sub>

## Engineering data and specifications

### Design applications

Table 11

Standard dimensions and weights of piping materials and conduit

Mechanical (ANSI & API standard, Schedule 40)					
Nominal std. pipe size (in.)	Pipe O.D. (in.)	Coupling O.D. (in.)	Weight of pipe lb/ft.	Weight of pipe filled w/water lb/ft.	
½	.84	1.06	0.85	0.98	
¾	1.05	1.31	1.13	1.36	
1	1.32	1.58	1.68	2.05	
1¼	1.66	1.90	2.27	2.92	
1½	1.90	2.20	2.72	3.60	
2	2.38	2.75	3.65	5.11	
2½	2.88	3.25	5.79	7.87	
3	3.50	4.00	7.58	10.78	
3½	4.00	4.63	9.11	13.39	
4	4.50	5.00	10.79	16.30	
5	5.56	6.30	14.62	23.28	
6	6.63	7.39	18.97	31.48	
8	8.63	9.23	28.56	50.24	
10	10.75	–	41.00	74.00	
12	12.75	–	50.00	99.00	
14	14.00	–	64.00	122.00	
16	16.00	–	63.00	142.00	
18	18.00	–	71.00	172.00	
20	20.00	–	79.00	205.00	
22	22.00	–	87.00	240.00	
24	24.00	–	95.00	277.00	
26	26.00	–	103.00	322.00	
28	28.00	–	111.00	364.00	
30	30.00	–	119.00	410.00	

Electrical conduit					
Nominal conduit size (in.)	Conduit O.D. (in.)	Weight of conduit lb/ft.	Rigid steel		Thin wall (EMT)
			Weight of conduit w/non-lead covered conductor lb/ft.		Conduit O.D. (in.)
½	0.84	0.85	1.04	0.71	0.29
¾	1.05	1.13	1.40	0.92	0.44
1	1.32	1.68	2.35	1.16	0.64
1¼	1.66	2.28	3.58	1.51	0.95
2	2.38	3.68	7.21	2.20	1.40
2½	2.88	5.82	10.22	2.88	2.30
3	3.50	7.62	14.51	3.50	2.70
4	4.50	10.89	21.48	4.50	4.00

Includes weight of heaviest conductor combination.

## Engineering data and specifications

### Design applications

Table 12

**Extra strong pipe (ANSI & API standard, Schedule 80)**

<b>A.S.A. B36.10 Schedule nos. and nominal wall thickness designations</b>						
<b>Nominal pipe size (in.)</b>	<b>O.D. (in.)</b>	<b>Wall thickness (in.)</b>	<b>I.D. (in.)</b>	<b>Weight of pipe lb/ft.</b>	<b>Water weight per ft. of pipe lb</b>	<b>Weight of pipe filled w/Water lb/ft.</b>
<b>Extra strong pipe and Schedule 80 pipe (through 8 in.)</b>						
3/8	0.675	0.126	0.423	0.74	0.061	0.801
1/2	0.840	0.147	0.546	1.09	0.101	1.191
3/4	1.050	0.154	0.742	1.47	0.188	1.668
1	1.315	0.179	0.957	2.17	0.311	2.481
1 1/4	1.660	0.191	1.278	3.00	0.555	3.555
1 1/2	1.900	0.200	1.500	3.63	0.765	4.395
2	2.375	0.218	1.939	5.03	1.279	6.309
2 1/2	2.875	0.276	2.323	7.66	1.834	9.497
3	3.500	0.300	2.900	10.30	2.860	13.16
3 1/2	4.000	0.318	3.364	12.55	3.850	16.35
4	4.500	0.337	3.826	15.00	4.98	19.98
5	5.563	0.375	4.813	20.80	7.89	28.69
6	6.625	0.432	5.761	28.60	11.29	39.89
8	8.625	0.500	7.625	43.40	19.79	63.20
<b>Extra strong pipe (10 in. through 24 in. OD)</b>						
10	10.750	0.500	9.750	54.70	32.30	87.00
12	12.750	0.500	11.750	65.40	47.00	112.40
14 OD	14.000	0.500	13.000	72.10	57.50	129.60
16 OD	16.000	0.500	15.000	82.80	76.50	159.30
18 OD	18.000	0.500	17.000	93.50	98.40	191.90
20 OD	20.000	0.500	19.000	104.10	122.80	226.90
24 OD	24.000	0.500	23.000	125.50	180.10	305.60
<b>Schedule 80 pipe (10 in. through 24 in. OD)</b>						
10	10.750	0.593	9.564	64.300	31.10	95.40
12	12.750	0.687	11.376	88.50	44.00	132.50
14 OD	14.000	0.750	12.500	106.10	53.20	159.30
16 OD	16.000	0.842	14.314	136.50	69.70	206.20
18 OD	18.000	0.937	16.126	170.80	88.50	259.30
20 OD	20.000	1.031	17.938	208.90	109.40	318.30
24 OD	24.000	1.218	21.564	296.40	158.30	454.70

## Engineering data and specifications

### Design applications

Table 13

Pipe covering weights (thickness intended as guide, only)

Nominal pipe size (in.)	260°		360°		440°		525°		600°		700°		800°	
	Thick. (in.)	lb/ft.	Thick. (in.)	lb/ft.	Thick. (in.)	lb/ft.	Thick. (in.)	lb/ft.	Thick. (in.)	lb/ft.	Thick. (in.)	lb/ft.	Thick. (in.)	lb/ft.
1	1	0.68	1	0.68	1	0.68	1	0.68	1½	1.19	1½	1.19	1½	1.19
1¼	1	0.75	1	0.75	1	0.75	1	0.75	1½	1.27	1½	1.27	2	1.82
1½	1	0.88	1	0.88	1	0.88	1	0.88	1½	1.45	1½	1.45	2	1.87
2	1	1.01	1	1.01	1	1.01	1½	1.53	1½	1.53	2	2.50	2	2.50
2½	1	1.15	1	1.15	1	1.15	1½	1.69	1½	1.69	2	2.50	2½	3.22
3	1	1.28	1	1.28	1	1.28	1½	2.09	1½	2.09	2	2.98	2½	3.98
3½	1	1.44	1	1.44	1½	2.29	1½	2.29	2	3.00	2	3.12	2½	4.30
4	1	1.60	1	1.60	1½	2.49	1½	2.49	2	3.49	2	3.49	2½	4.62
5	1	1.84	1	1.84	1½	2.84	1½	2.84	2	3.97	2	3.97	2½	5.92
6	1½	3.13	1½	3.13	1½	3.13	1½	3.13	2	4.54	2	4.54	2½	6.75
8	1½	4.06	1½	4.06	1½	4.06	1½	4.06	2	5.56	2	5.56	2½	7.61

Thickness and weight of calcium silicate covering.



# Engineering data and specifications

## Design applications – mechanical support

Table 14

**Column loading for rack construction**

Typical general storage rack for use with plywood or other decking.

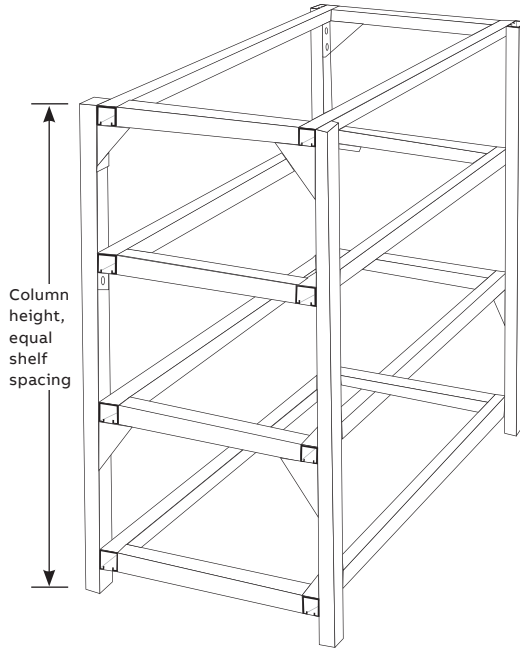

**General storage racks**

**Pallet racks**

**Barrel racks**

**Bulk furniture racks**

**Cable racks**

**Bar stock racks**

**Display racks**

**Special purpose racks**

For uniform loads on horizontal members, see Table 3

**Allowable load in lb per upright**

Column height	Cat. no.	Number of shelves per upright								
		2	3	4	5	6	7	8	9	10
6'	A1200	2,237	1,925	1,650	1,437	1,290	-	-	-	-
	A1202	4,170	3,580	3,100	2,730	2,450	-	-	-	-
	B1400	800	820	790	700	630	-	-	-	-
	B1402	1,930	1,700	1,500	1,300	1,190	-	-	-	-
7'	A1200	2,150	1,850	1,630	1,425	1,280	1,150	-	-	-
	A1202	4,000	3,525	3,000	2,700	2,430	2,200	-	-	-
	B1400	650	790	760	685	615	550	-	-	-
	B1402	1,800	1,650	1,450	1,300	1,180	750	-	-	-
8'	A1200	2,000	1,820	1,600	1,400	1,250	1,150	1,050	-	-
	A1202	3,900	3,475	3,000	2,700	2,400	2,185	2,000	-	-
	B1400	580	750	730	660	610	540	510	-	-
	B1402	1,650	1,610	1,450	1,300	1,160	940	970	-	-
9'	A1200	1,950	1,780	1,575	1,400	1,250	1,130	1,030	950	-
	A1202	3,800	3,400	3,020	2,675	2,400	2,180	1,975	1,800	-
	B1400		600	665	600	580	540	500	475	-
	B1402	1,500	1,500	1,430	1,275	1,160	1,000	900	800	-
10'	A1200	1,870	1,700	1,500	1,300	1,200	1,100	1,000	900	800
	A1202	3,600	3,300	3,000	2,650	2,350	2,000	1,975	1,800	1,650
	B1400		550	650	625	580	535	490	450	425
	B1402	1,450	1,480	1,400	1,250	1,140	1,040	960	885	825

# Engineering data and specifications

## Design applications – mechanical support

**Example 1**

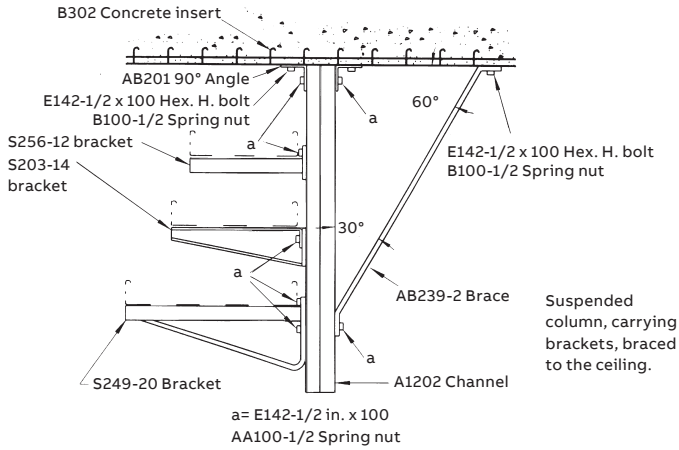

**Example 2**

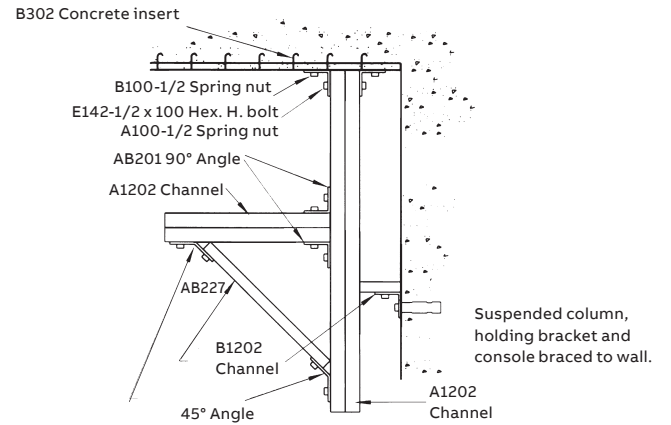

**Example 3**

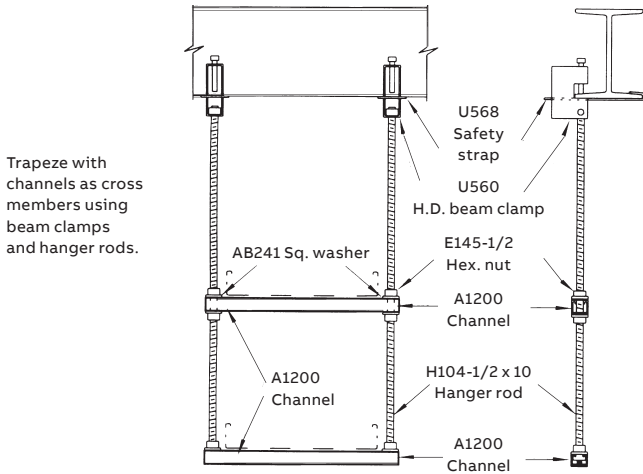

**Example 4**

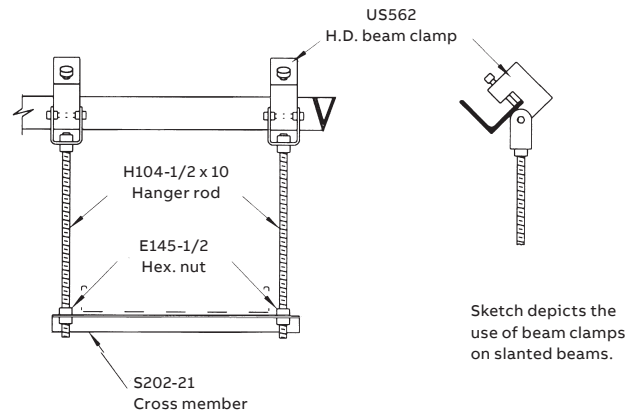

**Example 5**

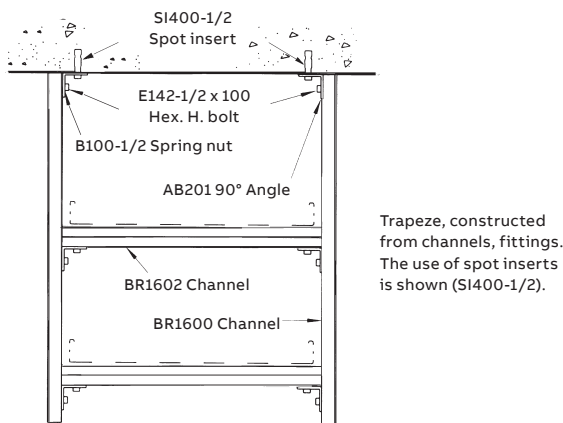

**Example 6**

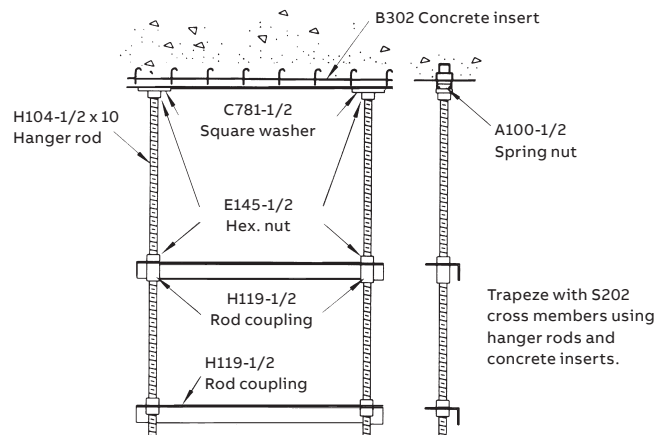

# Engineering data and specifications

## Design applications – mechanical support

**Example 7**

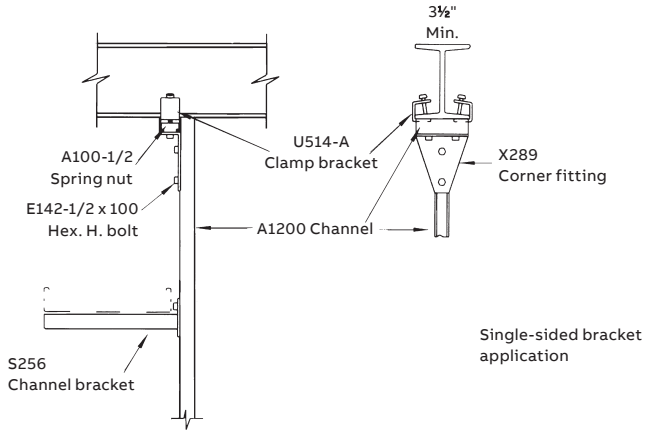

\*Note: Brace should be used for lengths greater than 30 in.

**Example 8**

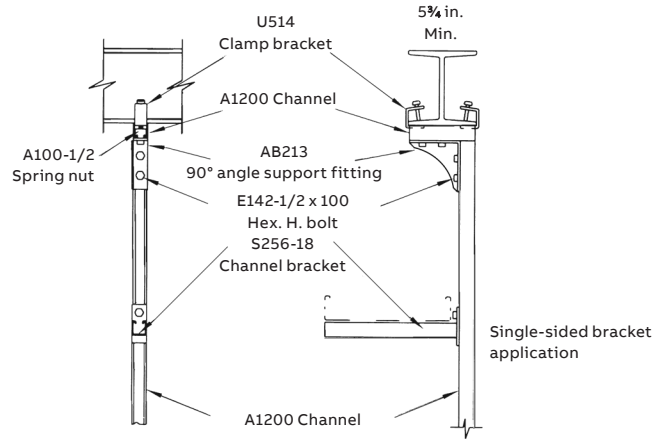

**Example 9**

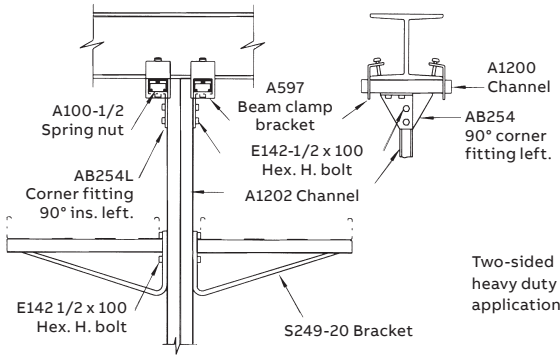

**Example 10**

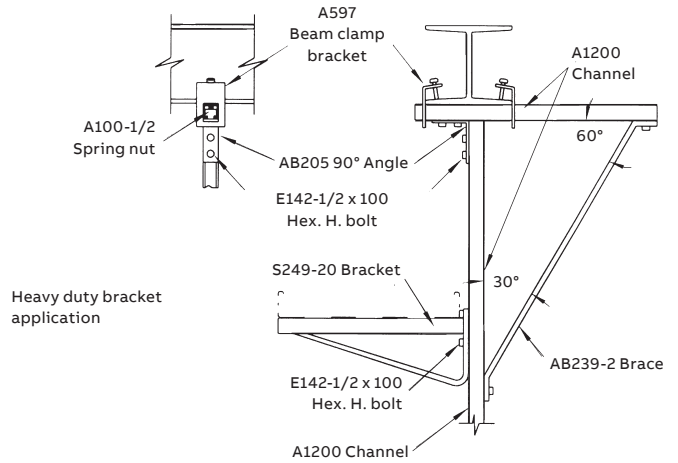

**Example 11**

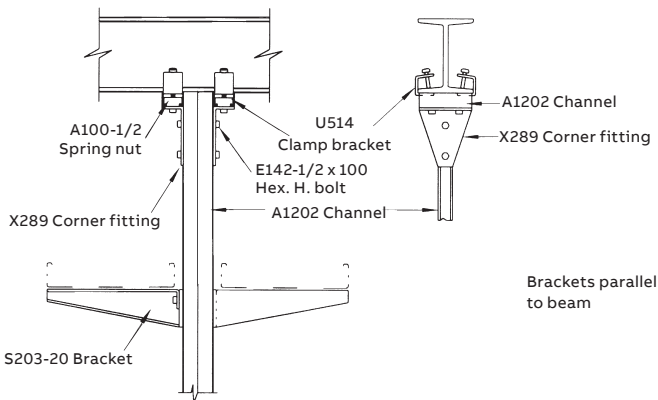

**Example 12**

